

Operating instructions and Spare Parts List

Metallic Nozzle Conversion Kit - PG 1 to PG 1-M

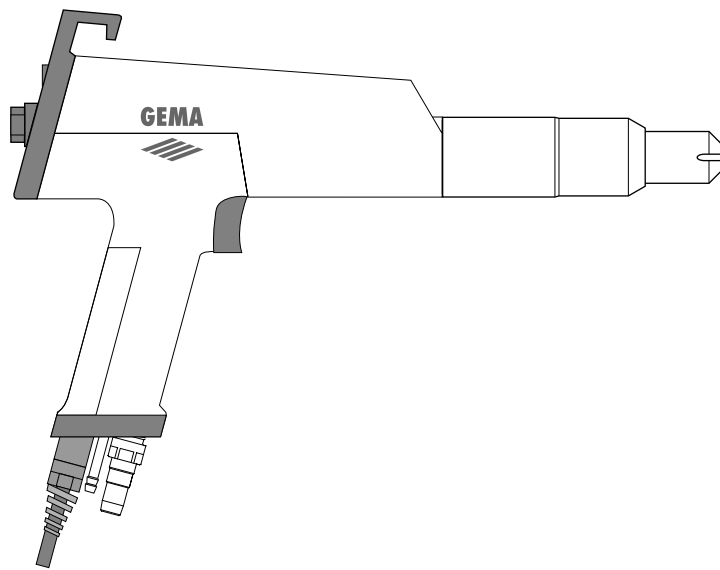

Table of Contents

Metallic Conversion Kit for the PG 1 Manual Powder Gun	1
About these Assembly and Operating Instructions	1
1. Field of application	1
2. Scope of Delivery	1
Converting the PG 1 to Metallic Nozzle	2
a) Replacing the powder tube and powder hose connection	2
b) Assembling the flat jet nozzle	4
Starting up	4
Conveying air and powder flow	4
Spare Parts List	5
Ordering Spare Parts	5
PG 1-M Metallic Gun	6
Metallic Nozzles	8

Metallic Conversion Kit for the PG 1 Manual Powder Gun

About these Assembly and Operating Instructions

These Assembly and operating instructions contain all the important information which is necessary for converting the PG 1 powder gun to the metallic nozzle version. In order to be able to fully utilize the properties of metallic nozzle, you should already be familiar with the working practice, and functioning of the complete powder coating plant. It is not the purpose of this manual to instruct in the use of the PG 1 Manual powder gun. If, however, problems arise during the operation with the metallic nozzle which are due to the PG 1 Manual powder Gun or PGC 1 Control Unit, then please read the functions of the corresponding operating instructions.

1. Field of application

The metallic nozzle conversion kit - Order no. 367 800, is ideal for all types of powder with a high metallic content, giving good powder charging properties and thereby achieving good coating results.

! When working with powders with high metallic content the manufacturer's instructions, as well as the local regulations, must be observed and followed exactly.

The powder charging, as well as the transfer efficiency, when using metallic nozzles with normal plastic powders are, in general, usually inferior to conventional nozzles.

2. Scope of Delivery

The conversion kit - Order no. 367 800 consists of :

Item A	Threaded sleeve	366 285
Item B	Powder tube	367 664
Item C	Flat jet nozzle - complete	367 478
Item D	Round jet nozzle	367 451
Item E	Deflector - \varnothing 24 mm	331 333
Item F	Powder hose connection (Aluminium)	348 430

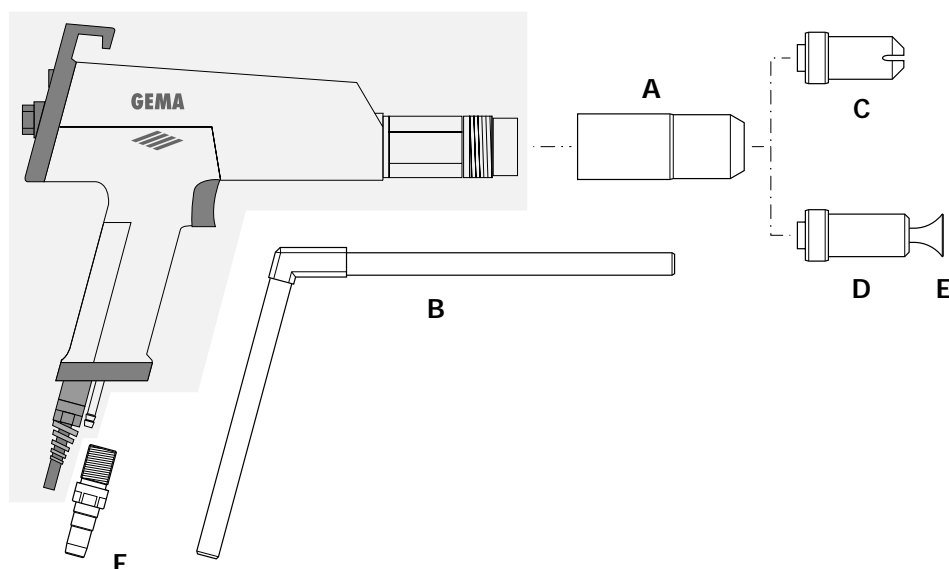

Figure 1

Converting the PG 1 to Metallic Nozzle

Before using the metallic nozzle it is necessary to dismantle the existing powder tube, as well as the powder hose connection of the PG 1 and replace with the parts supplied.

Attention : Before dismantling the gun make sure that the control unit is switched off and the gun connector is disconnected from the socket ("A Gun" - on the rear of the control unit).

a) Replacing the powder tube and powder hose connection

The metallic nozzle is only useful for coating with metallic powders. If it is necessary to coat with normal powder, the PG 1 gun must be converted to its original condition.

1. Remove the powder hose from the powder hose connection (15).
2. Remove the rinsing air hose from the connection (16).
3. Remove the threaded sleeve

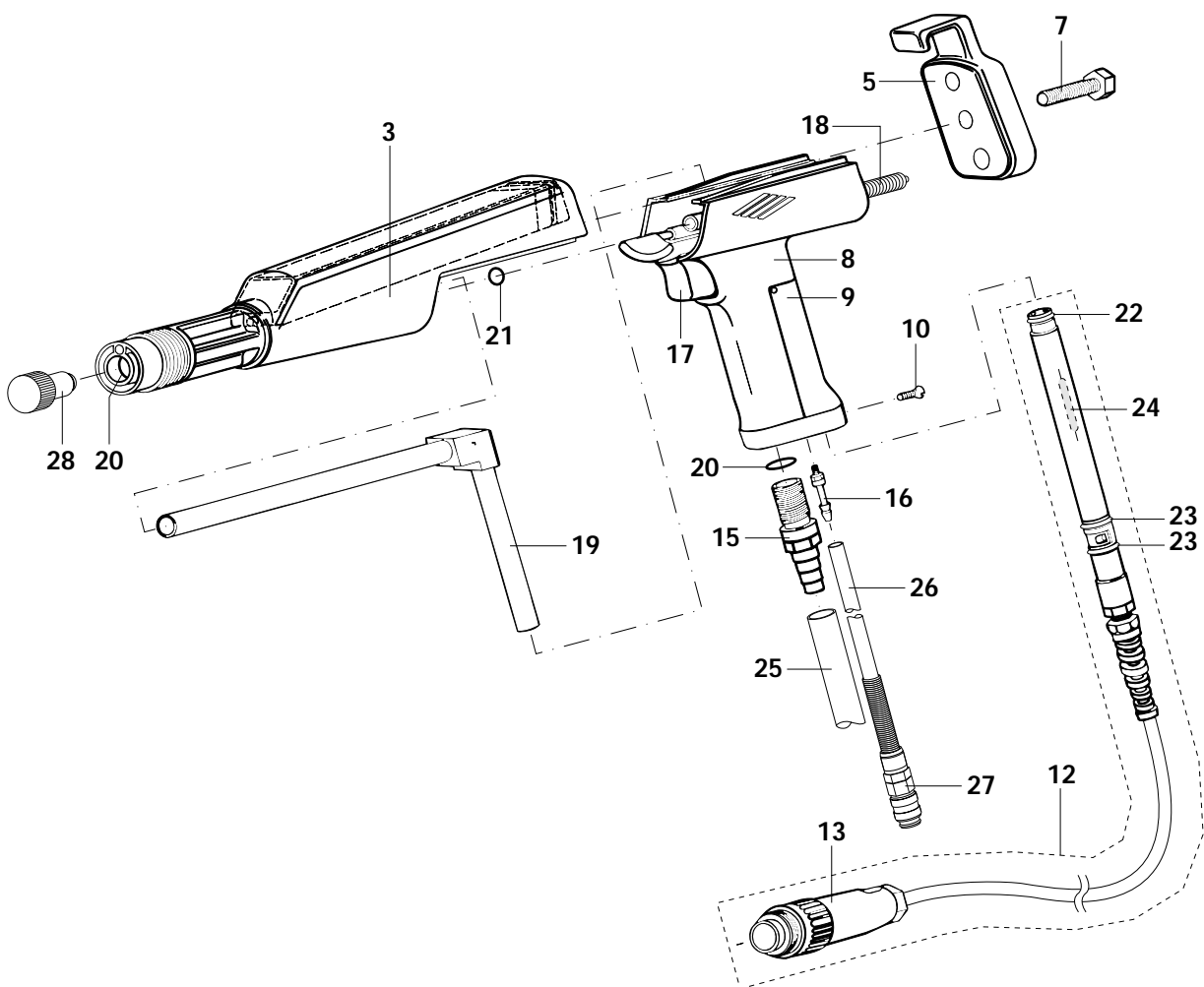

Figure 2

4. Unscrew the powder hose connection (15).
5. Unscrew the locking screw (10).
6. Turn the gun connection cable (12) a 1/4 turn to the left (Mark over the Mark) and pull **straight out**.
7. Screw in the locking screw provisionally.
Attention : This can be easily lost.
8. Unscrew the plastic screw (7) and remove the cover plate (5).
9. Place the extractor tool (28 - supplied in the spare parts set) in the front end of the shaft (3).
10. Remove the hand grip (8) from the shaft by pushing the extractor tool into the hole at the front of the shaft.
11. Pull the powder tube (19) out of the hand grip (8).
12. Screw in the new aluminium powder hose connection.
13. Place the long metallic powder tube into the hand grip (8).
14. Fit the powder tube into the shaft (3).
15. Reassemble the gun in the reverse order to that described above.
 - Careful handling must be observed!
 - If the gun cable connection (12) has to be inserted and turned with force, then the gun must be dismantled and reassembled.

After assembly check that :

- the gun cable connection (12) sits correctly and the locking screw (10) must screw completely into the countersink.
- there are no gaps at the joins.
- the gun trigger operates smoothly and returns to its original position on its own.

b) Assembling the flat jet nozzle

The prerequisite for the following steps is that the new powder tube and the powder hose connection have been previously assembled according to "Replacing the powder tube and powder hose connection".

Before fitting the flat jet nozzle make sure that the contacts on the gun nozzle are free from grease and powder, otherwise the electrical contact will not be properly made.

1. Fit the nozzle on the gun and tighten the threaded sleeve **slightly**.
2. When necessary turn the nozzle body to the desired position.
3. Screw on the threaded sleeve **well**.

Attention: If the threaded sleeve is fitted too loosely or not screwed on tight enough this could lead to damage to the gun and nozzle!

Starting up

Conveying air and powder flow

The conveying air and with it the powder flow can be adjusted on the PGC 1 Control unit with the control knob (1). If the conveying air pressure is increased with the control knob (1) then the powder flow is also increased accordingly.

For further details see also "PGC 1 Operating instructions".

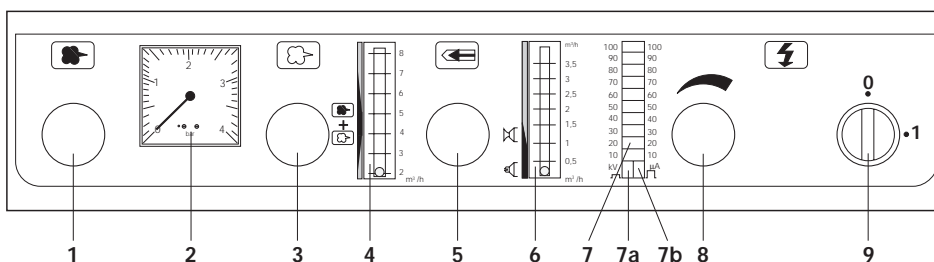

Figure 3

Spare Parts List

Ordering Spare Parts

When ordering spare part for your powder coating equipment, please indicate the following specifications :

1. Type and Serial number of your powder coating equipment.
2. Order number, quantity, and description of *each* spare part.

Example :

1. Type *PG 1*, **Serial no. :** *xxxx.xxxx*

2. Order no. : *232 670* , *2 pieces* , *O-Ring - ø 13.1x1.6*

When ordering cable or hose material the lengths required must also be given.

The spare part numbers of yard/metre ware always begin with 1.. ... and are always marked with an * in the spare parts list.

Wear parts are always marked with a # .

All dimension of plastic powder hoses are quoted as external (o/d) and internal (i/d) diameters:

e.g. : ø 8 / 6 mm = 8 mm outside diameter (o/d) / 6 mm inside diameter (i/d).

PG 1-M Metallic Gun

Remarks :

1. Only those parts which the user can replace without problem are found in the spare parts list.
2. If a part of the shaft (Item **3**) is broken or the High-Voltage cascade in the shaft is defect, then the whole shaft must be returned for inspection and repair.

The High-Voltage cascade is assembled in a special procedure and should not therefore be dismantled by the user.

3. If the gun cable (**12**) is defect, then the complete cable should be returned for inspection and repair.

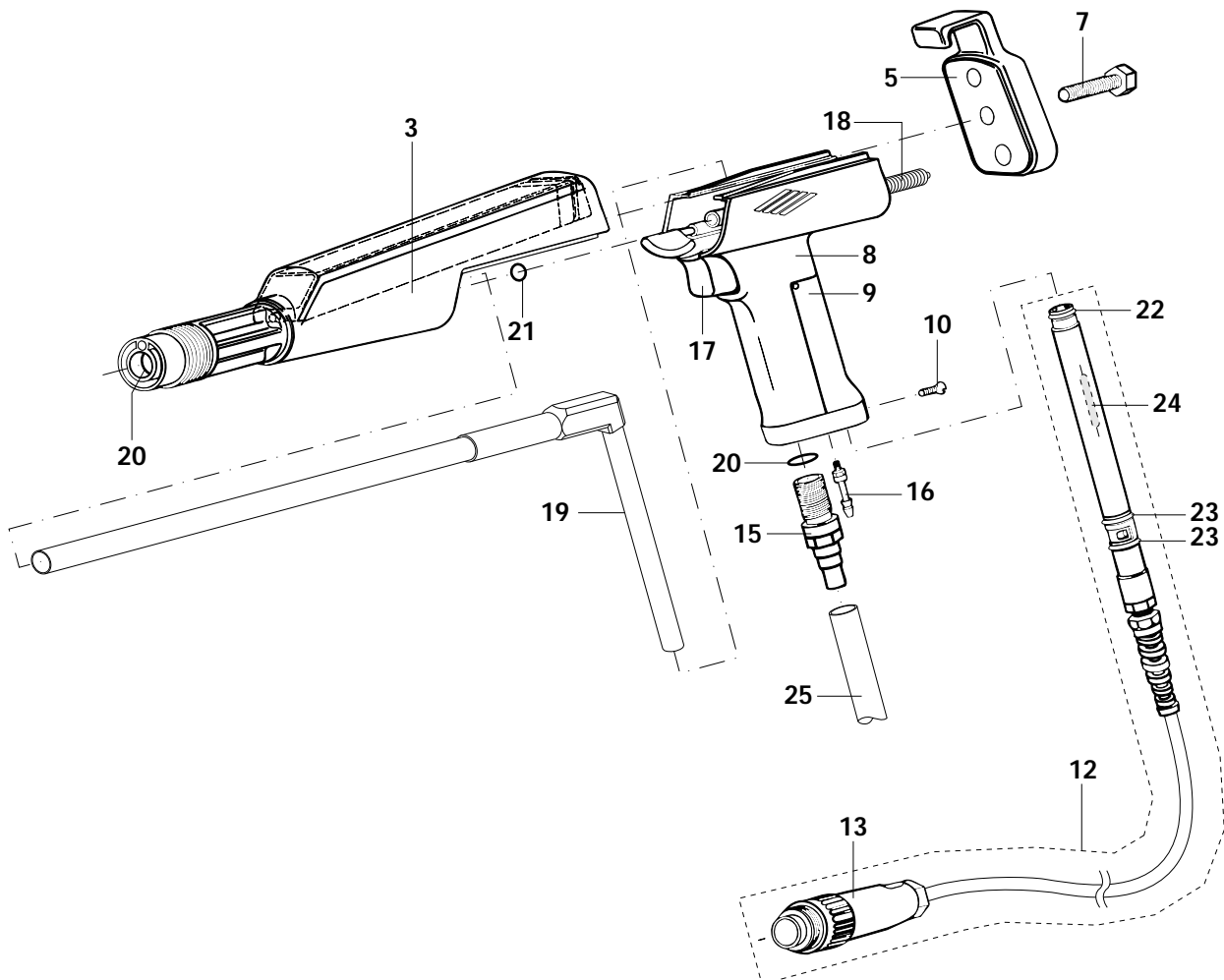



Figure 5

PG 1-M Metallic Gun

3	Shaft - complete, incl.: Shaft , Cascade, O-Rings (Items 20 / 21) Polarity – (negative)	338 249
5	Cover with hook	330 043
7	Plastic screw - M 8x35	328 847
8	Hand grip	330 035
9	Grounding plate	328 863
10	Lock screw - M 4x10	232 637
12	Gun cable (6 m) - complete Gun cable (11 m) - complete	328 740 336 025
12.1	Extension cable (5 m) for gun cable (Item 12)	334 464
12.2	Cable - only (for Item 12)	102 911*
13	Plug - 7 pole	200 085
15	Powder hose connection (Aluminium) with O-Ring (Item 20)	348 430
16	Rinsing air connection	328 820
17	Trigger with switching magnet	333 662
18	Spring	331 651
19	Powder tube	 367664#
20	O-Ring - ø 13.1x1.6 mm	232 670
21	O-Ring - ø 6.1x1.6 mm	233 099
22	O-Ring - ø 7.65x1.78 mm	232 564
23	O-Ring - ø 10.82x1.78 mm	232 556
24	Reed switch	328 910
25	Powder hose - ø 11 / 16 mm	103 128#*
26	Rinsing air hose - ø 6 / 4 mm	100 854*
27	Quick-release connection - ø 6 / 4 mm	200 840
28	Special extractor tool (for Item 19) Spiral brush (for Item 19)	340 839 333 514

* Indicate length required

Wear parts

Spare Parts List

Metallic Nozzles

3	Threaded sleeve	366 285
4	Flat jet nozzle - complete (incl. Item 5)	367 478
5	O-Ring - \varnothing 13.1x1.6 mm	232 670#
6	Round jet nozzle - complete (incl. Items 5 and 7)	367 451
7	O-Ring - \varnothing 5x1 mm	231 606#
8	Deflector - \varnothing 24 mm	331 333#
8.1	Deflector - \varnothing 16 mm	331 341#
8.2	Deflector - \varnothing 32 mm	331 325#
8.3	Deflector - \varnothing 50 mm	345 822#
8.4	Deflector - \varnothing 70 mm	353 949#

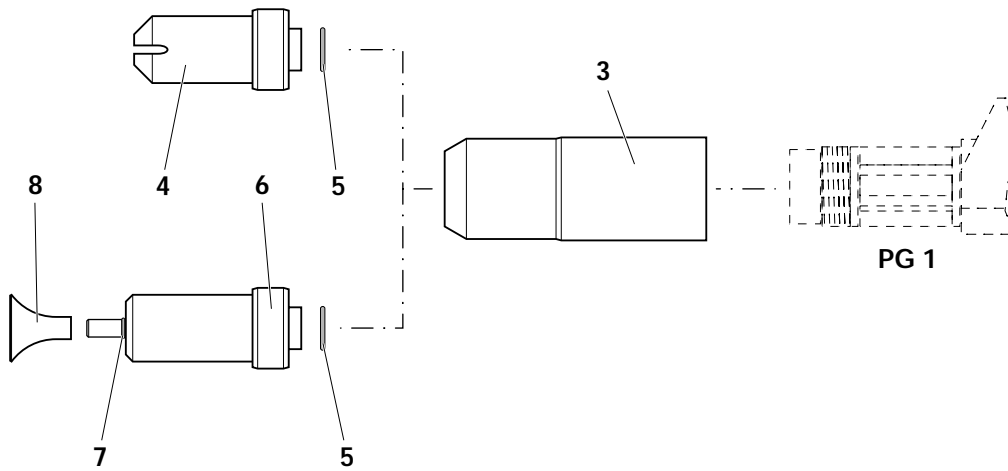

Wear parts

Figure 5

Notes :

Documentation Metallic Conversion Kit for PG 1

© Copyright 1997 Gema Volstatic AG, CH-9015 St.Gall.

All technical products from Gema Volstatic AG are constantly being developed based on our continuing research and applications. The data found in this publication may therefore change at any time without prior notification.

Printed in Switzerland