Operating instructions and Spare parts list

Manual gun OptiSelect Pro GM04-CF



Translation of the original operating instructions

Documentation OptiSelect Pro GM04-CF

© Copyright 2020 Gema Switzerland GmbH

All rights reserved.

This publication is protected by copyright. Unauthorized copying is prohibited by law. No part of this publication may be reproduced, photocopied, translated, stored on a retrieval system or transmitted in any form or by any means for any purpose, neither as a whole nor partially, without the express written consent of Gema Switzerland GmbH.

Gema, EquiFlow, MagicCompact, MagicCylinder, OptiCenter, OptiFlex, OptiGun, OptiSelect, OptiStar, OptiStar All-in-One and PowerBoost are registered trademarks of Gema Switzerland GmbH.

ClassicLine, ClassicStandard, ClassicOpen, DVC (Digital Valve Control), GemaConnect, MagicControl, MagicPlus, MonoCyclone, MRS, MultiColor, MultiStar, OptiAir, OptiControl, OptiColor, OptiFeed, OptiFlow, OptiHopper, OptiMove, OptiSieve, OptiSpeeder, OptiSpray, PCC (Precise Charge Control), RobotGun, SIT (Smart Inline Technology) and SuperCorona are registered trademarks of Gema Switzerland GmbH.

All other product names are trademarks or registered trademarks of their respective holders.

Reference is made in this manual to different trademarks or registered trademarks. Such references do not mean that the manufacturers concerned approve of or are bound in any form by this manual. We have endeavored to retain the preferred spelling of the trademarks, and registered trademarks of the copyright holders.

To the best of our knowledge and belief, the information contained in this publication was correct and valid on the date of publication. Gema Switzerland GmbH makes no representations or warranties with respect to the contents or use of this publication, and reserves the right to revise this publication and make changes to its content without prior notice.

For the latest information about Gema products, visit www.gemapowdercoating.com.

For information regarding patents, see www.gemapowdercoating.com/patents or www.gemapowdercoating.us/patents.

Gema Switzerland GmbH
Mövenstrasse 17
9015 St.Gallen
Switzerland

Phone: +41-71-313 83 00

Email: info@gema.eu.com

Table of contents

About these instructions	5
General information	5
Keeping the Manual	5
Safety symbols (pictograms).....	5
Structure of Safety Notes	6
Presentation of the contents	6
Figure references in the text	6
Safety	9
General	9
Basic safety instructions	9
Product specific security regulations	10
Product description	11
Intended use	11
Reasonably foreseeable misuse	12
Technical Data	12
Electrical data.....	12
Dimensions	12
Processible powders	12
Structure.....	13
Overall view.....	13
Scope of delivery.....	13
Available accessories**	13
SuperCorona ring.....	14
Principle of operation	15
High voltage generation	15
Circuit	15
Powder flow and electrode rinsing air	15
Flat jet nozzle with rinsed central electrode	16
Round jet nozzle with rinsed deflector and rinsed central electrode	16
Typical properties – characteristics of the functions	17
Funnel cup with cover	17
Reproducible coating parameters	17
Fast color changes.....	17
Connection for SuperCorona Ring.....	17
Assembly / Connection	19
Connecting the gun	19
Start-up	21
Preparation for start-up	21
Prerequisites	21
Initial start-up.....	22
Setting the device type.....	22

Operation	23
Operation	23
Setting powder output and powder cloud	23
Electrode rinsing air	25
Decommissioning / Storage	27
Shutdown	27
When the product will not be used for several days	27
Storage conditions	27
Hazard notes	27
Type of storage	27
Storage duration	27
Space requirements	27
Physical requirements	28
Maintenance during storage	28
Maintenance schedule	28
Maintenance works	28
Maintenance / Repairs	29
Interval	29
Gun maintenance	29
Cleaning	29
Gun cleaning	30
Cleaning the spray nozzle	30
Replacing parts	31
Dismantling the gun	31
Plug gauge for checking wear of insert sleeves	33
Troubleshooting	35
Disposal	37
Introduction	37
Requirements on personnel carrying out the work	37
Disposal regulations	37
Materials	37
Spare parts list	39
Ordering spare parts	39
OptiSelect Pro GM04-CF – spare parts list	40
SuperCorona	42
Accessories	43
Flat jet nozzles – overview (wearing parts)	43
Round jet nozzles – overview (wearing parts)	44
Gun extensions	45
Spray nozzles for extensions – overview (wearing parts)	46
Other accessories	47
Index	49

About these instructions

General information

This operating manual contains all the important information that is needed to operate the OptiSelect Pro GM04-CF. It will safely guide you through the start-up process and give you references and tips for the optimal use when working with your powder coating system.

Information about the functional mode of the individual system components should be referenced in the respective enclosed documents.

Keeping the Manual

Please keep this Manual ready for later use or if there should be any queries.

Safety symbols (pictograms)

The following warnings with their meanings can be found in the Gema instructions. The general safety precautions must also be followed as well as the regulations in the relevant instructions.

DANGER

Indicates a hazardous situation, which, if not avoided, will result in death or serious injury.

WARNING

Indicates a hazardous situation, which, if not avoided, could result in death or serious injury.

CAUTION

Indicates a hazardous situation, which, if not avoided, could result in minor or moderate injury.

ATTENTION

Indicates a potentially harmful situation. If not avoided, the equipment or something in its surrounding may be damaged.

ENVIRONMENT

Indicates a potentially harmful situation, which, if not avoided, may have harmful consequences for the environment.

**MANDATORY NOTE**

Information that must be observed.

**NOTICE**

Useful information, tips, etc.

Structure of Safety Notes

Every note consists of 4 elements:

- Signal word
- Nature and source of the danger
- Possible consequences of the danger
- Prevention of the danger

⚠ SIGNAL WORD

Nature and source of the hazard!

Possible consequences of the danger

- ▶ Prevention of the danger

Presentation of the contents

Figure references in the text

Figure references are used as cross references in the descriptive text.

Example:

"During the typical OptiCenter (7) operation, the powder bag is put in the powder bag cone. The powder is fluidized in the bag with the fluidizing/suction lance and then fed to the OptiSpeeder (9). The fluidized powder is sucked in by the conveyors and fed through the powder hoses to the guns/spray nozzles (8). The powder, which does not adhere to the workpieces, will be absorbed by the exhaust air of the booth (1) and separated from the air in the cyclone separator (2)."

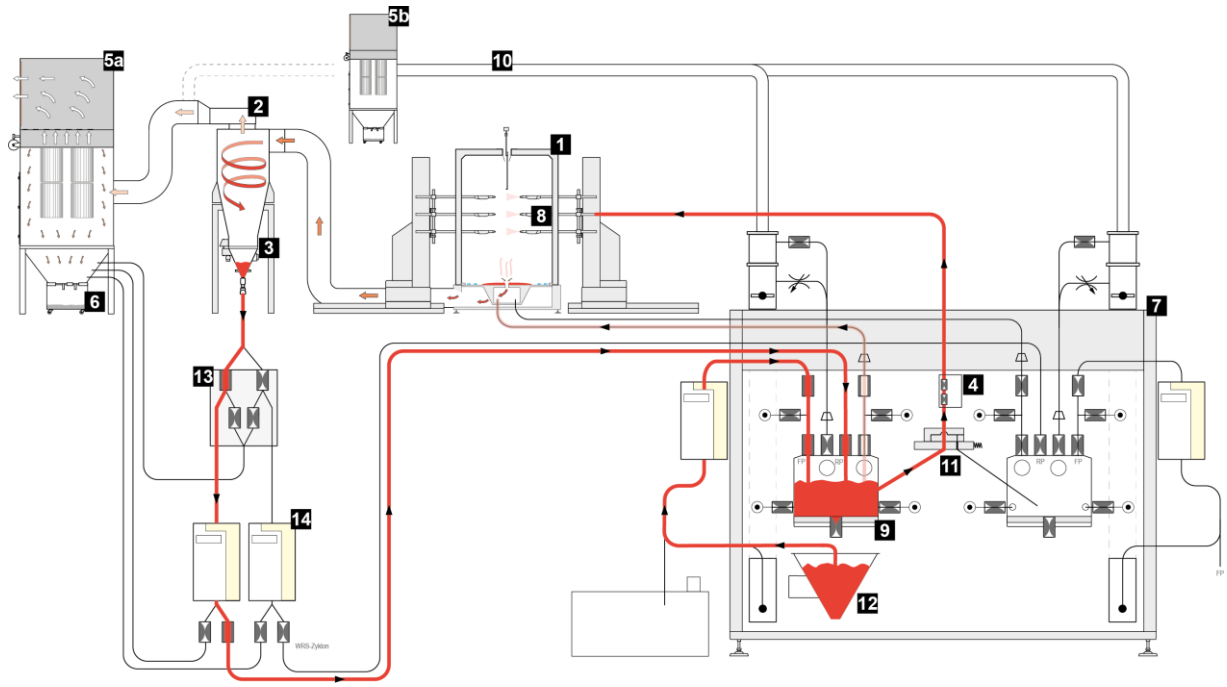

Safety

General

This chapter sets out the fundamental safety regulations, that must be followed by the user and third parties using this product.

These safety regulations must be read and understood before the product is put into operation.

The standards and guidelines applied during the development, manufacture and configuration are described in the EC declaration of conformity and in the manufacturer's declaration.

WARNING

Working without instructions

Working without instructions or with individual pages from the instructions may result in damage to property and personal injury if relevant safety information is not observed.

- ▶ Before working with the device, organize the required documents and read the section "Safety regulations".
 - ▶ Work should only be carried out in accordance with the instructions of the relevant documents.
 - ▶ Always work with the complete original document.
-

Basic safety instructions

- This product is built to the latest specification and conforms to the recognized technical safety regulations and is designed for the normal application of powder coating.
- Any other use is not considered as intended use. The manufacturer shall not be liable for damage resulting from such use; the user bears sole responsibility for such actions. If this product is to be used for other purposes or other substances outside of our guidelines then Gema Switzerland GmbH should be consulted.
- Start-up (i.e. the execution of intended operational tasks) is forbidden until it has been established that this product has been set up and wired according to the guidelines for machinery. The standard "EN ISO 12100 Machine safety" must also be observed. Machine safety
- Unauthorized modifications to the product exempt the manufacturer from any liability from resulting damage.

- The relevant accident prevention regulations, as well as other generally recognized safety regulations, occupational health and structural regulations are to be observed.
- Furthermore, the country-specific safety regulations also must be observed.

Product specific security regulations

- This product is a constituent part of the equipment and is therefore integrated in the system's safety concept.
- If it is to be used in a manner outside the scope of the safety concept, then corresponding measures must be taken.
- The installation work to be done by the customer must be carried out according to local regulations.
- It must be ensured, that all components are earthed according to the local regulations before start-up.



For further security information, see the more detailed Gema safety regulations!

Product description

Intended use

Designed for use with organic powders, this gun is used for electrostatic coating of objects connectable to ground. The gun works in conjunction with the control units and accessories, as specified in the corresponding Type Examination Certificate.



fig. 1

Observance of the operating, service and maintenance instructions specified by the manufacturer is also part of conformity of use. This product should only be used, maintained and started up by trained personnel, who are informed about and are familiar with the possible hazards involved.



Any other use is considered non-compliant. The manufacturer is not responsible for any incorrect use and the risks associated with such actions are assumed by the user alone!

Reasonably foreseeable misuse

- Coating of non grounded objects
- Use of enameled powder
- Incorrectly configured values for powder conveyance
- Incorrectly configured values for electrode rinsing air
- Use of moist powder

Technical Data

Electrical data

OptiSelect Pro GM04-CF	
Nominal input voltage	eff. 10 V
Frequency	18 kHz (average)
Nominal output voltage	110 kV
Polarity	negative (optional positive)
Max. output current	110 µA
Ignition protection	Ex 2 mJ T6
Temperature range	5 °C - +40 °C (+41 °F - +104 °F)
Max. surface temperature	85 °C (+185 °F)
Protection type	IP64
Approvals	 2813  II 2 D PTB 19 ATEX 5001
	 For Electro. Fin. Appl. CL. II, Spray Matl. Amb. temp 32° to 104°F

Dimensions

OptiSelect Pro GM04-CF	
Weight Funnel cup (without cover)	725 g
Weight Funnel cup 300 ml with cover	130 g
Weight Funnel cup 600 ml with cover	150 g

Processible powders

OptiSelect Pro GM04-CF	
Plastic powder	yes
Metallic powder	yes
Enamel powder	no

Structure

Overall view

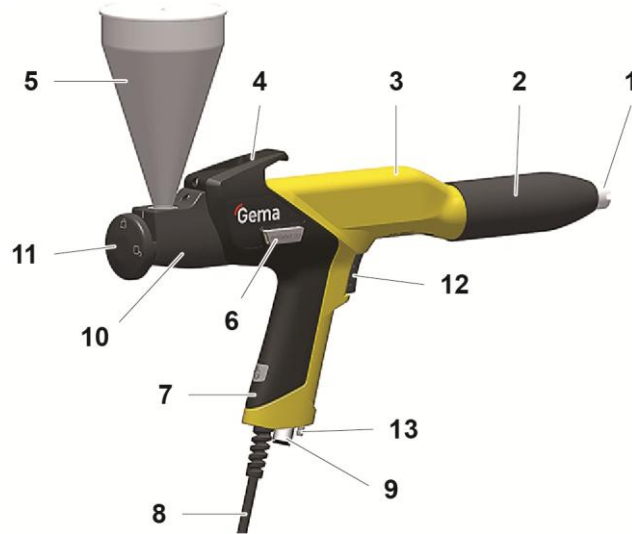

fig. 2:

- | | | | |
|---|------------------------|----|------------------------------|
| 1 | Spray nozzle system | 8 | Gun cable |
| 2 | Threaded sleeve | 9 | Supplementary air connection |
| 3 | Shaft | 10 | Injector |
| 4 | Rear part with hook | 11 | Rotary knob |
| 5 | Funnel cup | 12 | Trigger |
| 6 | SuperCorona connection | 13 | Conveying air connection |
| 7 | Gun handle | | |

Scope of delivery

- manual gun with gun cable (6 m), negative polarity
- Funnel cup 300 ml with cover
- Flat jet nozzle NF20, complete (incl. electrode holder)
- Cable tie with Velcro closure
- Gun cleaning brush
- Multi-spray adapter
- Spare parts kit
- Operating manual

Available accessories**

- SuperCorona ring
- Flat jet nozzles
- Round jet nozzles
- Gun extension 150 and 300 mm
- Funnel cup 600 ml

– Gloves, anti-static

**for more information, see spare parts list

SuperCorona ring

Field of application

The SuperCorona is an optional extension for the gun, allowing for a better surface quality when coating with the powder coating equipment.

When coating wheel rims, drawers, radiators, lamps etc. the surface quality is exceptional, also in places with higher coating layer requirements. By coating with several powder types, an "orange peel" finish can be completely avoided. By coating with structure powder, the "picture frame effect" is hardly visible.

The performance of the gun with SuperCorona is convincing due to its very good charging and very high deposition rate as well as an improved penetration into Faraday cages. The distance between nozzle and workpiece can be reduced to 100 mm without influencing the surface finish.

Due to its modular structure, the gun can be fast and easily extended with the light SuperCorona (approx. 60 g). The gun remains repair-friendly and easy to maintain even after reconfiguration.

SuperCorona assembly

Before fitting the SuperCorona ring, make sure that the connection and the plug-in connector are free from grease and powder; otherwise the electric contact cannot be guaranteed.



Principle of operation

High voltage generation

The control unit supplies a high-frequency low voltage signal of approx. 10 V eff. This voltage is fed through the gun cable (1) to the high voltage cascade (2) in the gun shaft.

In the high voltage cascade (2), the low voltage is high-transformed in a first step (c). This primary high voltage is subsequently rectified and multiplied in the high voltage cascade in a second step (d), until the required high voltage is obtained at the end (approx. 110 kV). The high voltage is now fed to the electrode (E) within the spray nozzle.

Circuit

In addition to the modulated low voltage needed for high voltage generation, there are signal lines fed through the gun cable. The control signals are used for monitoring gun trigger status and gun remote control functions.

The gun is released by a touch-free switch (3), which is operated by a magnet (4) in the trigger (5). The gun control unit switches on the modulated low voltage, the powder transport and the rinsing air.

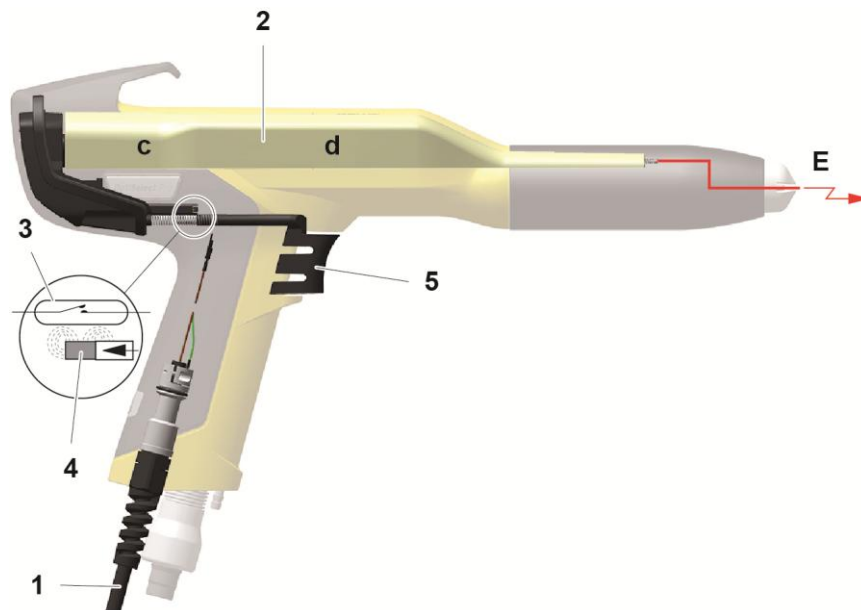

fig. 3

Powder flow and electrode rinsing air

The electrode rinsing air is used inside spray nozzles and enters through the gun handle. The connection of the gun and the functions of the spray nozzles are described in the corresponding section of this document.

Flat jet nozzle with rinsed central electrode

The vented flat jet nozzle serves for the spraying and the charging of the powder. The powder is charged by the central electrode (**E**). The high voltage (**H**) created in the gun cascade is guided through the center electrode.

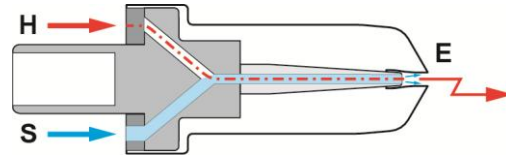

fig. 4

In order to prevent powder from sintering on the electrode, compressed air is used during the spray process.

This compressed air (**S**) (known as electrode rinsing air) can be adjusted on the gun control unit, depending on the gun type (see corresponding operating manual).

Round jet nozzle with rinsed deflector and rinsed central electrode

The deflector is used, to give the powder stream emerging from the gun, a cloud formation. The powder is charged by the central electrode (**E**). The high voltage (**H**) created in the gun cascade is guided through the center electrode.

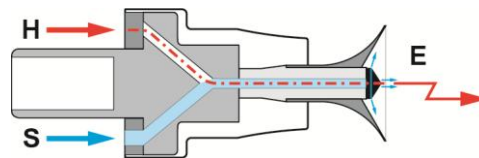

fig. 5

Since powder can accumulate on the baffle plate, it must be rinsed with compressed air.

This compressed air (**S**) (known as electrode rinsing air) can be adjusted on the gun control unit, depending on the gun type (see corresponding operating manual).

Typical properties – characteristics of the functions

Funnel cup with cover



- Volume: 300 ml or 600 ml
- Designed for processing very small quantities of powder
- Robust threaded connection for safe and fast assembly/disassembly
- High quality material for durable use

Reproducible coating parameters

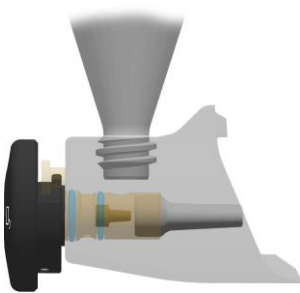

All pneumatic and electrostatic parameters of the application are precisely monitored and controlled via the gun control and the fully integrated injector module.

Fast color changes



Thanks to tool-free disassembly and full visibility of the powder-transporting components, a high-quality color change can be performed very fast.

Connection for SuperCorona Ring



- Quick and simple connection to and disconnection from the SuperCorona ring

Assembly / Connection

Connecting the gun

The gun is delivered ready-to-use by the manufacturer. Just a few cables and hoses must be connected.



The compressed air must be free of oil and water!

The gun is connected as follows:

1. Connect the red quick release connection (with integrated powder stop) with the Quick release coupling of the conveying air hose.
 - The conveying air hose must already be connected to the output **1.2** on the rear side of the control unit.
2. Connect the black quick release connection (with integrated powder stop) with the Quick release coupling of the supplementary air hose.
 - The supplementary air hose must already be connected to the output **1.3** on the rear side of the control unit.
3. Connect the conveying air hose as well as the supplementary air hose to the gun
4. Lay out the gun cable, conveying air hose and supplementary hose and bind them using Velcro strips (included)
5. Connect the gun cable plug to the socket **2.3** on the rear side of the control unit
6. Thread the enclosed nut with screw cap **(4)** onto the fluidizing air connection and closing coupling **(5)** onto the electrode rinsing air connection

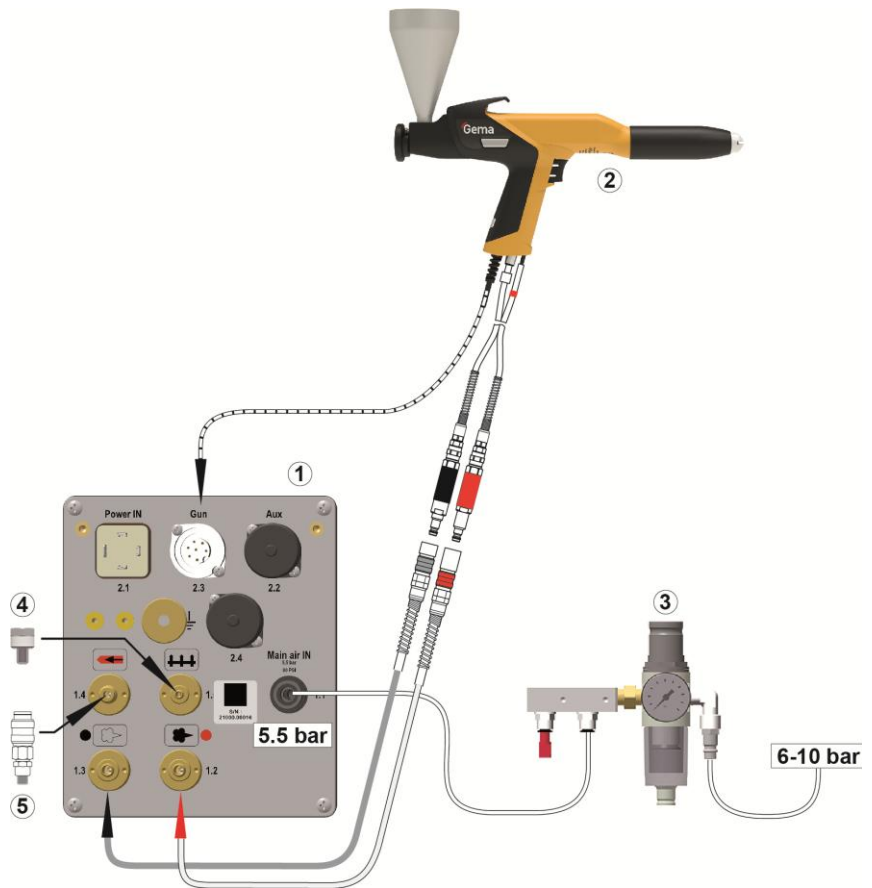

fig. 6

- | | | | |
|---|------------------|---|--------------------|
| 1 | Gun control unit | 3 | Maintenance unit |
| 2 | Gun | 4 | Nut with screw cap |
| | | 5 | Closing coupling |

Start-up

Preparation for start-up

Prerequisites

When starting up the gun control unit, the following preconditions which impacting the coating results must be met into consideration:

- Gun correctly connected
- Gun control unit correctly connected
- Corresponding power and compressed air supply available
- Powder preparation and powder quality OK

Initial start-up



If a malfunction occurs, see the troubleshooting guide, as well as the gun control unit operating manual!

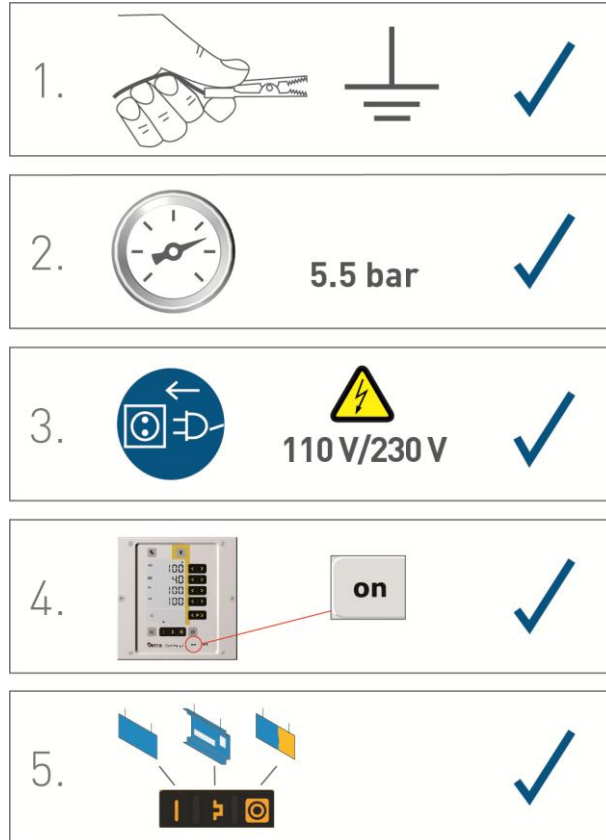

fig. 7



The remainder of the start-up procedure for the gun is explicitly described in the operating instructions for the OptiStar CGxx manual powder gun control unit (chapter "Initial start-up" and "Daily start-up")!

Setting the device type



If the control unit is supplied as a component of a manual coating unit, then the corresponding system parameter is set correctly by the factory!

ATTENTION

A wrong parameterization leads to various malfunctions!

- ▶ For more on this, please also see the operating instructions for the gun control unit!

Operation

⚠ WARNING

Holding the gun incorrectly

During the coating process, the gun can discharge along the body of the coater if not held using its intended handle, which has been grounded.

- ▶ Always hold gun only by the handle!
- ▶ Do not touch any other parts of the gun!



In order for the gun to produce a good spray pattern, make sure that the rotary knob is in the correct position.

- ▶ Turn the rotary knob into the correct position



fig. 8:

Operation

Setting powder output and powder cloud

The powder output depends on the selected powder output (in %), and the powder cloud on the selected total air volume.



As a factory default value, a powder rate of 50% and a total air volume of 2.5 Nm³/h are recommended.

- If values are entered that the gun control unit cannot implement, then the operator is informed of this by a blinking in the relevant display and a temporary error message!

Setting the total air volume

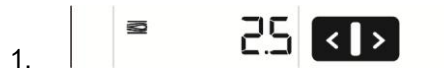

Adjust the total air volume on the gun control unit with the **T3/T4** keys

- Adjust total air volume according to the corresponding coating requests



correct powder cloud

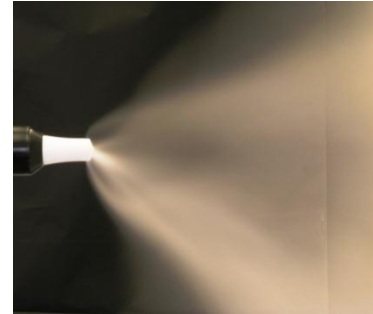

too little total air

Setting the powder output



much powder



little powder

Adjust the powder output volume (e.g. according to the desired coating thickness)

- Factory default setting of 50% is recommended for initial operation. The total air volume is thereby kept constant automatically by the control unit.



To achieve maximum efficiency, we recommend avoided an overly high powder volume where possible!

2. Check fluidization of the powder in the funnel cup
3. Point the gun into the booth, switch the gun on and visually check the powder output

Electrode rinsing air

With this type of gun, the required amount of electrode rinsing air is automatically supplied to the electrode.

The prerequisite for this function is that the corresponding system parameter is already set correctly in the gun control unit.

ATTENTION

A wrong parameterization leads to various malfunctions!

- ▶ For more on this, please also see the operating instructions for the corresponding gun control unit!

Decommissioning / Storage

Shutdown

1. End the coating procedure
2. Switch off the control unit



The adjustments for high voltage, powder output volume and electrode rinsing air remain stored.

When the product will not be used for several days

1. Switch off the power to the control unit at the main switch
2. Clean the gun and the components for powder conveying (see therefore the corresponding user manuals)
3. Turn off the compressed air main supply

Storage conditions

Hazard notes

There is no danger to personnel or the environment if the unit is stored properly.

Type of storage

The product must be stored horizontally for safety reasons.

Storage duration

If the physical conditions are maintained, the unit can be stored indefinitely.

Space requirements

The space requirements correspond to the size of the product.

There are no special requirements concerning distance to neighboring equipment.

Physical requirements

Storage must be inside a dry building at a temperature between +5 and +50 °C. Do not expose to direct sunlight!

Maintenance during storage

Maintenance schedule

No maintenance schedule is necessary.

Maintenance works

During long-term storage, periodically perform a visual check.

Maintenance / Repairs

Interval

Gun maintenance

The gun is designed to require only a minimum amount of maintenance.

1. Clean the gun with dry cloth, see chapter "Maintenance"
2. Remove the injector nozzle (refer to chapter "Dismantling the gun")
3. Check the injector nozzle with enclosed plug gauge for checking wear (refer to chapter "Plug gauge for checking wear")
4. Replace the injector nozzle, if necessary.

Cleaning

ATTENTION

Any unauthorized modifications and alterations to the product are not permitted for safety reasons and exclude the manufacturer's liability for any resulting damage!



Regular and conscientious cleaning and maintenance increase the service life of the product and ensure consistent high coating quality!

- The parts to be replaced during maintenance work are available as spare parts. These parts can be found in the appropriate spare parts list!

Gun cleaning

ATTENTION

Prohibited solvents

The following solvents may not be used to clean the gun:

- ▶ Ethylene chloride, acetone, ethyl acetate, methyl ethyl ketone, methylene chloride, premium gasoline, turpentine, tetrachloromethane, toluene, trichloroethylene, xylene!



Only cleaning agents with a flash point of a least 5 Kelvin above the ambient temperature, or cleaning places with technical ventilation are allowed!



Before cleaning the powder gun, switch off the control unit. The compressed air used for cleaning must be free of oil and water!

Daily:

1. Blow off the outside of the gun and wipe, clean etc.

Weekly:

2. Remove the application cup
3. Remove the spray nozzle from the gun and clean it with compressed air
4. Blow through the gun with compressed air, beginning from the connection in flow direction
5. Clean the integrated gun tube with the brush supplied, if necessary
6. Blow through the gun with compressed air again
7. Clean the application cup
8. Reassemble the gun and connect it

Cleaning the spray nozzle

Daily or after every shift

1. Clean the inside and outside of the spray nozzle with compressed air.
Never immerse the parts in solvents!
2. Check the seating of the spray nozzles.

ATTENTION

Threaded sleeve not tightened well

Loose mounting of the spray nozzle poses a risk of high voltage discharge from the gun, potentially damaging it!

- ▶ Always tighten the threaded sleeve well!

Weekly:

1. Remove the spray nozzle and clean on the inside with compressed air. If sintering has formed, then removal of this sintered powder is required!

Monthly

1. Check spray nozzle for wear

The flat jet nozzle is to be replaced, if:

- the spray pattern is no longer a regular oval
- deeper grooves are in the nozzle slot, or even the wall thickness is no longer recognizable
- the wedge of the electrode holder is worn

Nozzles with deflectors:

- if the wedge of the electrode holder is worn down, then the electrode holder is to be replaced

Replacing parts

Except for the replacement of possible defective parts, there are very few repairs to be made.



The cascade can be replaced trouble-free.

The repair of the gun cable connection, however, may only be made by an authorized Gema Service center.

- Contact your Gema representative for details!
-

Dismantling the gun

General information



The gun should only be dismantled, if this is required because of a defect or pollution.

- Dismantle the gun only so far, as the desired part is accessible!
-

⚠ WARNING

Touching the gun parts

During work on the gun, the gun can if touched.

- ▶ Before dismantling the gun, switch off the control unit and disconnect the gun plug!
-

Dismantling procedure

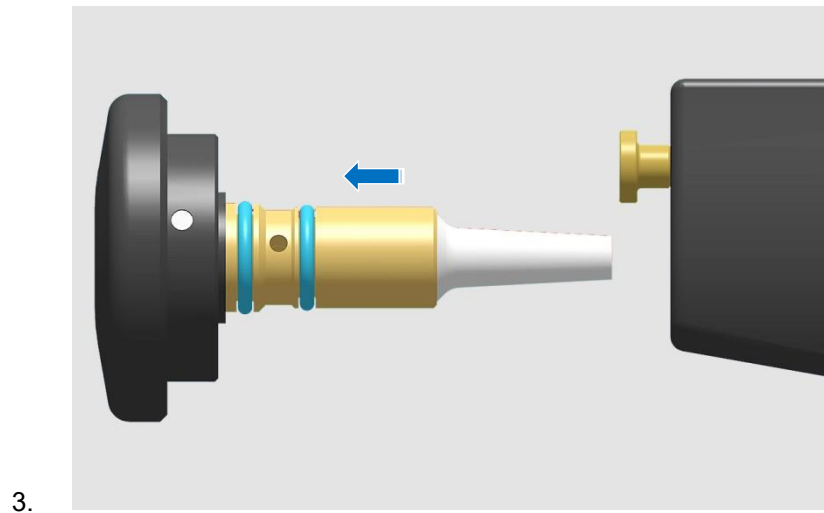
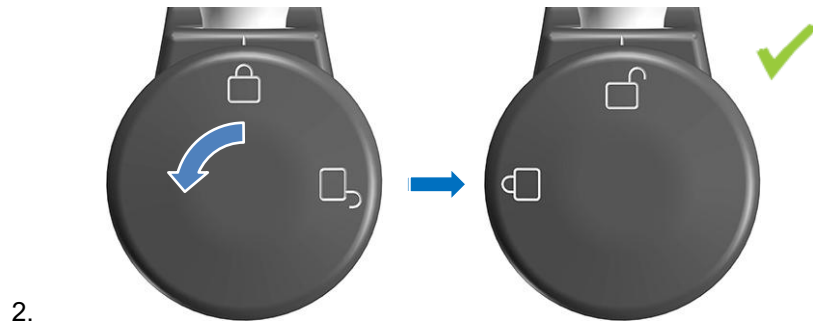

Assembling the powder gun

The assembling is to be carried out in the reverse order to that shown above.



1.

Plug gauge for checking wear of insert sleeves

The influence of wear on the insert sleeve is very important. Worn insert sleeves produce a much lower powder output than new insert sleeves. Wear on the insert sleeve occurs internally, is hardly visible from the outside, and the inlet diameter is not affected.



Wear and tear of the gun and components will depend on the intensity and amount of use of the gun; and therefore should be checked regularly.

The condition of the insert sleeve can be checked, with the insert sleeve still mounted in the injector module with the Multi-Tool (Order No. 1020 180), as follows:

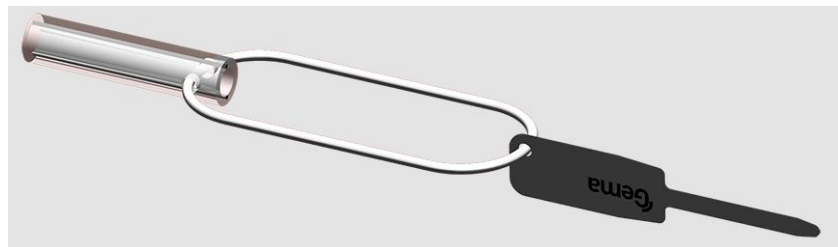
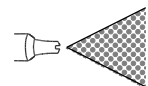
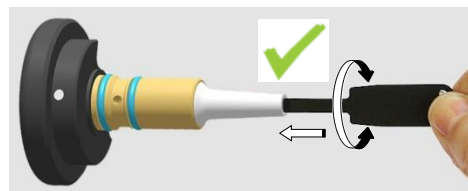
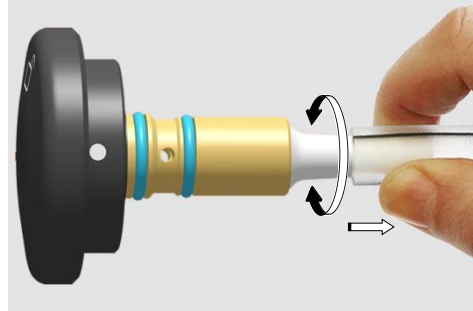

fig. 9: Multi-Tool



= 100%



- Replace worn insert sleeve (see also “Spare parts list”)

Troubleshooting



Additional error descriptions are to be found also in the control unit operating instructions!

Incident	Causes	Corrective action
H11 (Help code on control unit)	Gun not connected	Connect the gun
	Gun plug or gun cable defective	Contact local Gema representative
Powder does not adhere to object, although the gun is triggered and sprays powder	High voltage and current deactivated	Check the high voltage and current setting
	High voltage cascade defective	Contact local Gema representative
	Nozzle defective	Replace
	The objects are not properly grounded	Check the grounding
The gun does not spray powder, although the control unit is switched on and the gun trigger is pressed	Compressed air not present	Connect the equipment to the compressed air
	Insert sleeve in the injector module clogged or not inserted	Clean or insert the corresponding part
	Nozzle in the injector module clogged	Clean the corresponding part
	Cup not tightened well	Tighten the cup
	Pressure valve in the control unit defective	Replace
	Solenoid valve in the control unit defective	Replace
	No conveying air: <ul style="list-style-type: none"> – Throttle motor defective – Solenoid valve defective 	Contact local Gema representative
	Front plate defective	Contact local Gema representative

Incident	Causes	Corrective action
Gun achieving only poor spray profile	Total air incorrectly configured	Increase the powder quantity and/or total air volume on the control unit
	Pneumatic hoses for conveying air/supplementary air not correctly connected or interchanged	Connect the pneumatic hoses correctly – refer to chapter “Connecting the gun”
	Air lines to the gun bent, damaged or clogged	Check air lines to gun
	Insert sleeve in the injector worn or not inserted	Replace or insert it
	Powder doesn't flow through the cup: <ul style="list-style-type: none"> – Rotary knob is not in the correct position – Powder with insufficient flow properties 	<ul style="list-style-type: none"> – Turn the rotary knob into the correct position – Contact powder manufacturer / local Gema representative

Disposal

Introduction

Requirements on personnel carrying out the work

The disposal of the product is to be carried out by the owner or operator.

When disposing of components that are not manufactured by Gema, the instructions in the respective manufacturer's documentation must be observed.

Disposal regulations



The product must be disassembled and disposed of properly at the end of its service life.

- ▶ When disposing of the product, the applicable local and regional laws, directives and environmental regulations must be complied with!
-

Materials

The materials must be sorted according to material groups and taken to the appropriate collection points.

Spare parts list

Ordering spare parts

When ordering spare parts for your product, please indicate the following specifications:

- Type and serial number of your product
- Order number, quantity and description of each spare part

Example:

- **Type** Manual gun OptiSelect Pro GM04-CF
Serial number 1234 5678
- **Order no.** 203 386, 1 piece, Clamp – Ø 18/15 mm

When ordering cable or hose material, the required length must also be given. The spare part numbers of this bulk stock is always marked with an *.

The wearing parts are always marked with a #. marked.

All dimensions of plastic hoses are specified with the external and internal diameter:

Example:

Ø 8/6 mm, 8 mm outside diameter (o/d) / 6 mm inside diameter (i/d)

⚠ WARNING

Use of non-original Gema spare parts

Use of Non-Gema replacement spare parts may invalidate some or all approval certificates and accreditations; and the user assumes all explosion risks associated with use of these parts. Use of these replacement spare parts may void any and all warranty claims.

- ▶ Use only original Gema spare parts!

OptiSelect Pro GM04-CF – spare parts list



Only parts were included in the spare parts list, which the user can replace himself without problems!

- ▶ If the powder gun cable is defective, it is to be completely sent in for repair!

A	OptiSelect Pro GM04-CF manual powder gun – complete incl. flat jet nozzle, brush and parts kit, Funnel cup 300 ml, with:	
	Gun cable 6 m, negative polarity (–)	1019 701
	Gun cable 6 m, positive polarity (+)	1019 702
B	Manual powder gun shaft OptiSelect Pro GM04-CF (incl. cascade) with:	
	Gun cable 6 m, negative polarity (–)	1019 691
	Gun cable 6 m, positive polarity (+)	1019 692
1	Gun body – complete	1019 650
2	Cascade – complete, negative polarity, incl. pos. 3	1016 911
	Cascade – complete, positive polarity, incl. pos. 3	1016 912
3	Buffer	1017 704
4	Print holder – complete	1019 655
5	Rear part	1019 675
6	Trigger – complete	1017 686
7	Trigger cover	1017 688
8	Countersunk screw – M4x6 mm	1017 698
9	SuperCorona connection	1017 684
10	Gun cable 6 m – complete	1019 686
11	Rinsing air connection	1017 656
12	Connection tube – complete (incl. pos. 12.1)	1019 689
12.1	O-ring for pos. 12 – Ø 4x1 mm	234 877#
13	Powder tube – complete (incl. pos. 13.1, 13.2, 13.3)	1019 660#
13.1	O-ring for pos. 13 – Ø 10x1.5 mm	1019 683#
13.2	O-ring for pos. 13 – Ø 11x1.5 mm	1019 684#
13.3	O-ring for pos. 13 – Ø 12x1.5 mm	1000 822#
14	Air tube – complete (incl. pos. 14.1)	1019 679
14.1	O-ring for pos. 14 – Ø 3.5x1 mm	1019 696#
15	Screw-in nipple – 1/8"-Ø 8 mm	240 087
16	Threaded sleeve (see corresponding spare parts list)	
17	Nozzle (see corresponding spare parts list)	
18	Cable protection	1017 685
19	Screw – M3x20 mm	1017 674
20	Contact strip	1018 707
21	Fitting bush	1018 708
22	Injector body – complete (incl. pos. 23)	1019 680
23	Retaining screw	357 464
24	Injector module – complete (incl. pos. 24.1, 24.2, 25)	1019 670
24.1	O-ring for pos. 24 – Ø 10x2 mm	1019 668#

24.2	O-ring for pos. 24 – Ø 11x2 mm	1019 669#
25	Insert sleeve	1019 673#
26	Screw – M3x12 mm	1019 687
27	Funnel cup – 300 ml	1019 693
	Funnel cup – 600 ml	1019 666
28	Cup cover – Ø 80 mm, complete	1019 724
	Cup cover – Ø 100 mm, complete	1019 725
29	Screw – M6x16 mm	1017 673
30	Cascade buffer	1023 235
40	Cleaning brush – Ø 9 mm (not shown)	1020 179
41	Spare parts kit – consisting of (not shown):	
	Insert sleeve (1x)	1019 673#
	Multi tool (1x)	1020 180
	O-ring – Ø 10x2 mm (1x)	1019 668#
	O-ring – Ø 11x2 mm (1x)	1019 669#
	Multi-spray adapter (1x)	1003 634#
	Cable clamp (1x)	303 070

* Please indicate length

Wearing part

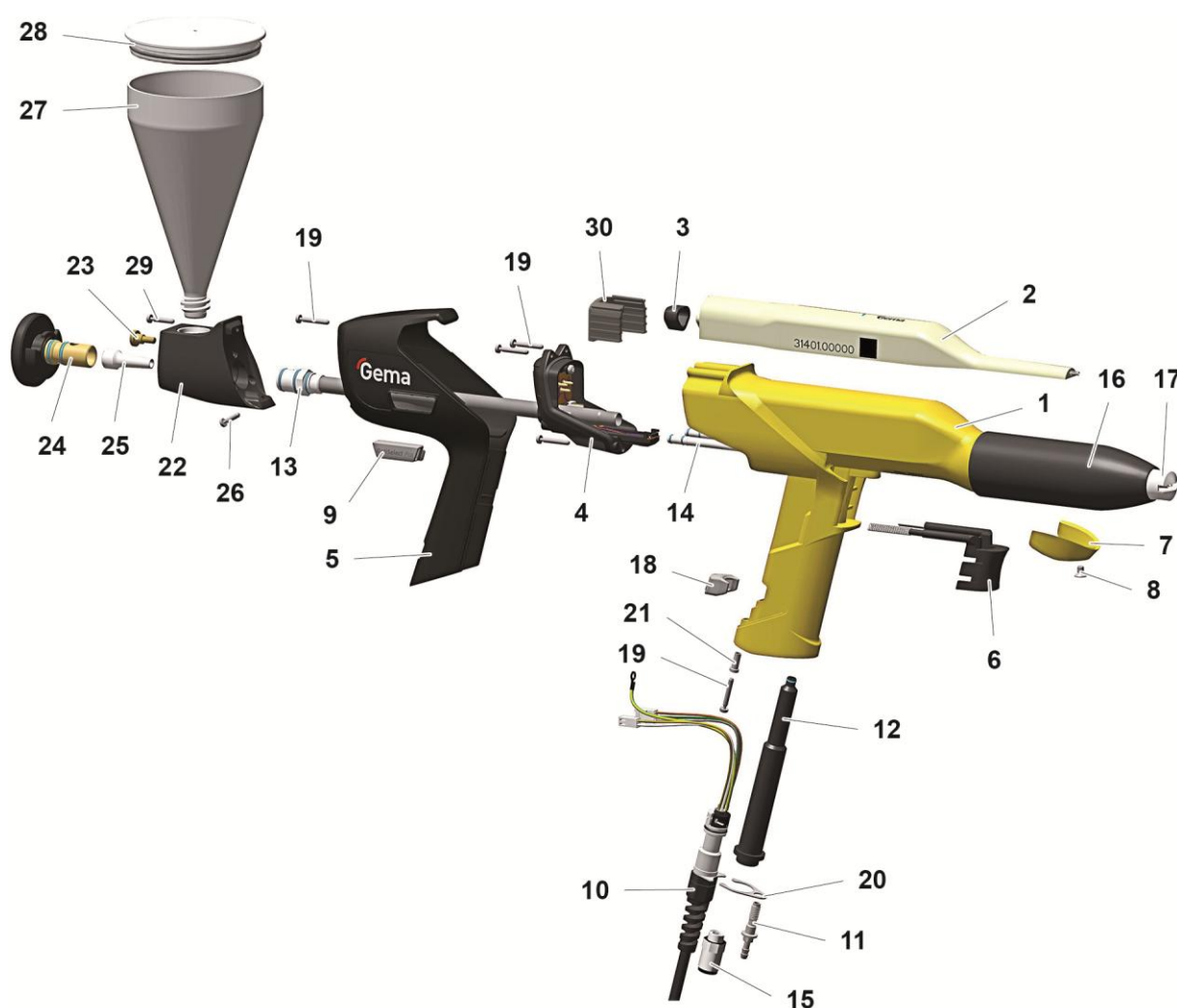

fig. 10: OptiSelect Pro GM04-CF – spare parts

SuperCorona

1 SuperCorona PC..

1018 291#

Wearing part

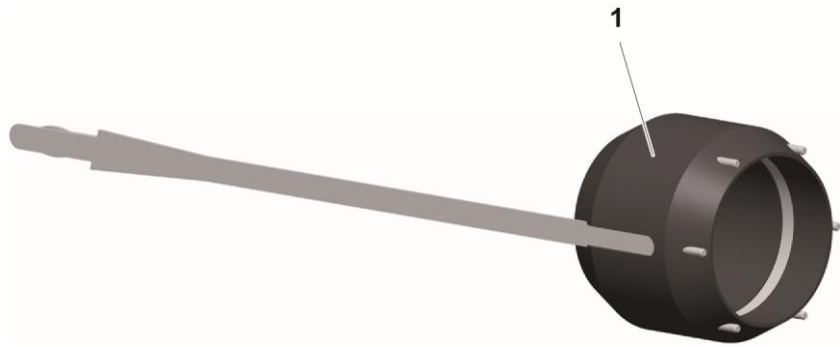









fig. 11



Accessories

Flat jet nozzles – overview (wearing parts)







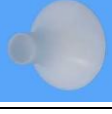

Application	A	B	A + B	Threaded sleeve
Profiles/flat parts	 NF20 1010 090		NF20 1010160	 1007 229
Profiles/flat parts	 NF27 1010 752		NF27 1010 754	
Complex profiles and depressions	 NF21 1007 935	 1007 683	NF21 1007 932	
Complex parts (deep recess); target spraying	 NF22 1008 145		NF22 1008 140	
Profiles/big flat parts	 NF40* 1018 165		NF40 1018 166	
Large surfaces	 NF24* 1008 147		NF24 1008 142	

* not suitable for angled nozzles

Round jet nozzles – overview (wearing parts)

Application	A	B	A + B	Threaded sleeve	Deflectors
Suitable for large surfaces	 NS04 1008 151	 1008 152	NS04 1008 150	 1007 229	
					Ø 16 mm 331 341
					Ø 24 mm 331 333
					Ø 32 mm 331 325

Gun extensions

Gun extensions		
	L = 150 mm	L = 300 mm
without nozzle ¹	 1008 616	 1008 617
without nozzle ²	 1007 718	 1007 719
with Flat jet nozzle NF25	 1007 746	 1007 747
with Round jet nozzle NS09	 1007 748	 1007 749

¹ see NF27, NF20, NF21, NF24, NS04

² see NF25, NF26, NS09

ATTENTION

Connecting more than two extensions

It is not permitted to connect more than two extensions together, in order to prevent the gun from being damaged by arising leverage force.

- ▶ The extensions (150 mm/300 mm) may be connected TO ONLY ONE ADDITIONAL extension (150 mm/300 mm), if necessary.







**Spray nozzles for extensions – overview
(wearing parts)**



1007 718

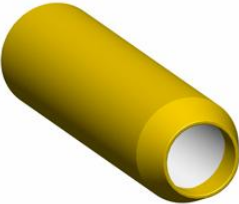

1007 719

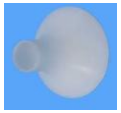
Application	A	B	A + B	Threaded sleeve	Deflectors
Profiles/flat parts	 NF25 1007 735	 1007 684	NF25 1007 743	 1007 740	--
Complex profiles and depressions	 NF26 1007 742	1007 684	NF26 1007 744		--
Suitable for large surfaces	 NS09 1008 257	 1008 258	NS09 1008 259		 Ø 16 mm 331 341 Ø 24 mm 331 333 Ø 32 mm 331 325

Other accessories

**Gloves, anti-static
(1 pair)**

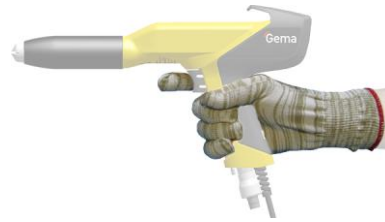

800 254

Index

A		N	
About these instructions.....	5	Nozzles	
Assembly.....	19	Flat jet nozzle.....	16
B		Round jet nozzle.....	16
Basic safety instructions.....	9	O	
C		Operation.....	23
Cleaning.....	29	P	
Connection.....	19	Pictograms.....	5
D		Presentation of the contents.....	6
Decommissioning.....	27	Product description.....	11
Disposal.....	37	Product specific security regulations.....	10
Disposal regulations.....	37	R	
Disuse for several days.....	27	Repairs.....	29
E		S	
Electrical data.....	12	Safety.....	9
F		Safety symbols.....	5
Figure references in the text.....	6	Shutdown.....	27
I		Spare parts list.....	39
Intended use.....	11	Start-up.....	21
M		Storage.....	27
Maintenance.....	29	Storage conditions.....	27
Maintenance during storage.....	28	T	
		Technical Data.....	12
		Troubleshooting.....	35

