Operating instructions and spare parts list

Manual coating equipment

OptiFlex 2 Q



Translation of the original operating instructions

Documentation OptiFlex 2 Q

© Copyright 2010 Gema Switzerland GmbH

All rights reserved.

This publication is protected by copyright. Unauthorized copying is prohibited by law. No part of this publication may be reproduced, photocopied, translated, stored on a retrieval system or transmitted in any form or by any means for any purpose, neither as a whole nor partially, without the express written consent of Gema Switzerland GmbH.

MagicCompact, MagicCylinder, MagicPlus, MagicControl, OptiFlex, OptiControl, OptiGun, OptiSelect, OptiStar and SuperCorona are registered trademarks of Gema Switzerland GmbH.

OptiFlow, OptiCenter, OptiMove, OptiSpeeder, OptiFeed, OptiSpray, OptiSieve, OptiAir, OptiPlus, OptiMaster, MultiTronic, EquiFlow, Precise Charge Control (PCC), Smart Inline Technology (SIT) and Digital Valve Control (DVC) are trademarks of Gema Switzerland GmbH.

All other product names are trademarks or registered trademarks of their respective holders.

Reference is made in this manual to different trademarks or registered trademarks. Such references do not mean that the manufacturers concerned approve of or are bound in any form by this manual. We have endeavored to retain the preferred spelling of the trademarks, and registered trademarks of the copyright holders.

To the best of our knowledge and belief, the information contained in this publication was correct and valid on the date of publication. Gema Switzerland GmbH makes no representations or warranties with respect to the contents or use of this publication, and reserves the right to revise this publication and make changes to its content without prior notice.

For the latest information about Gema products, visit www.gemapowdercoating.com.

For patent information, see www.gemapowdercoating.com/patents or www.gemapowdercoating.us/patents.

Printed in Switzerland

Gema Switzerland GmbH
Mövenstrasse 17
9015 St.Gallen
Switzerland

Phone: +41-71-313 83 00

Fax.: +41-71-313 83 83

E-Mail: info@gema.eu.com

Table of contents

| | |
|---|-----------|
| General safety regulations | 3 |
| Safety symbols (pictograms)..... | 3 |
| Proper use..... | 8 |
| Product-specific safety measures | 8 |
| OptiFlex 2 Q Manual coating equipment | 8 |
| About this manual | 9 |
| General information | 9 |
| Product description | 11 |
| Field of application | 11 |
| Utilization..... | 11 |
| Reasonably foreseeable misuse..... | 12 |
| Technical data..... | 12 |
| Connectable guns | 12 |
| Powder output (guide values) | 12 |
| Guide values for OptiStar CG13 with OptiFlow Injector IG06..... | 13 |
| Air flow rates | 13 |
| Electrical data | 13 |
| Pneumatic data | 14 |
| Dimensions | 14 |
| Processible powders..... | 14 |
| Design and function | 15 |
| General view | 15 |
| Scope of delivery | 16 |
| OptiFlex 2 Q..... | 16 |
| Typical properties – Characteristics of the functions | 16 |
| Processing the powder directly from the original powder manufacturer's container | 16 |
| Freely rotating head piece | 16 |
| Commissioning | 17 |
| Preparation for start-up | 17 |
| Basic conditions | 17 |
| Set-up..... | 17 |
| Mounting instructions | 18 |
| Connection instructions..... | 19 |
| Initial start-up | 21 |
| Set head piece | 22 |
| Setting the device type..... | 22 |
| Operation | 23 |
| Coating..... | 23 |
| Setting the background illumination..... | 27 |
| Color change..... | 28 |
| General information | 28 |
| Shutdown | 30 |

| | |
|--|-----------|
| Cleaning and maintenance | 31 |
| Daily maintenance | 31 |
| Weekly maintenance | 31 |
| If in disuse for several days | 31 |
| Powder hose rinsing | 31 |
| Cleaning | 32 |
| Cleaning the fluidizing/suction unit | 32 |
| Cleaning the OptiSelect GM03 manual powder gun | 32 |
| Maintenance and cleaning of the filter unit | 33 |
| Replacing the filter element | 33 |
| | |
| Fault remedying | 35 |
| General information | 35 |
| | |
| Spare parts list | 37 |
| Ordering spare parts | 37 |
| OptiFlex 2 Q - Spare parts list | 38 |
| OptiFlex 2 Q - Spare parts list | 39 |
| OptiFlex 2 Q Dual Gun - Spare parts list | 40 |
| OptiFlex 2 Q - Pneumatic group | 41 |
| OptiFlex 2 Q Dual Gun - Pneumatic group | 42 |

General safety regulations

This chapter sets out the fundamental safety regulations that must be followed by the user and third parties using OptiFlex 2 Q manual coating equipment.

These safety regulations must be read and understood before the OptiFlex 2 Q is put into operation.

Safety symbols (pictograms)

The following warnings with their meanings can be found in the Gema operating instructions. The general safety precautions must also be followed as well as the regulations in the operating instructions.

**DANGER!**

Danger due to electrically live or moving parts. Possible consequences: death or serious injury

**WARNING!**

Improper use of the equipment could damage the machine or cause it to malfunction. Possible consequences: minor injuries or damage to equipment

**INFORMATION!**

Useful tips and other information



General information

The OptiFlex 2 Q manual coating equipment is state of the art equipment that conforms to the recognized technical safety regulations and is designed for normal powder coating applications.

Any other use is considered non-compliant. The manufacturer shall not be liable for damage resulting from such use; the user bears sole responsibility for such actions. Gema Switzerland GmbH must be consulted before OptiFlex 2 Q manual coating equipment is used for any other purposes or substances beyond those indicated here.

Observance of the operating, service and maintenance instructions specified by the manufacturer is also part of conformity of use.

The relevant accident prevention regulations, as well as other generally recognized safety regulations, occupational health and structural regulations are to be observed.

Furthermore, the country-specific safety regulations also must be observed.

Additional safety and operation notices can be found on the accompanying CD or on the homepage www.gemapowdercoating.com.



General dangers

Start-up is forbidden until it has been established that the OptiFlex 2 Q manual coating equipment has been set up and wired according to the EU guidelines for machinery.

Unauthorized modifications to the OptiFlex 2 Q Manual coating equipment exempt the manufacturer from any liability from resulting damages or accidents.

The operator must ensure that all users have received appropriate training for powder spraying equipment and are aware of the possible sources of danger.

Any operating method, which will negatively influence the technical safety of the powder spraying equipment, is to be avoided.

For your own safety, only use accessories and attachments listed in the operating instructions. The use of other parts can lead to risk of injury. Only original Gema spare parts should be used!

Repairs must only be carried out by specialists or by authorized Gema service centers. Unauthorized conversions and modifications can lead to injuries and damage to the equipment, and the Gema Switzerland GmbH guarantee would no longer be valid.



Electrical
danger

The connecting cables between the control unit and the spray gun must be installed so as to eliminate the possibility of damage during the operation. Please observe the local safety regulations!

The plug connections between the powder spraying equipment and the mains should only be removed when the power supply is switched off.

All maintenance activities must take place when the powder spraying equipment is switched off.

The powder coating equipment may not be switched on until the booth is in operation. If the booth stops, the powder coating device must switch off too.



Explosion hazard

The control units for the spray guns must be installed and used in zone 22. Spray guns are allowed in zone 21.

Only original Gema OEM parts are guaranteed to maintain the explosion protection rating. If damages occur related to the use of spare parts from other manufacturers, all relevant warranty or compensation claims are void!

Conditions leading to dangerous levels of dust concentration in the powder spraying booths or in the powder spraying areas must be avoided. There must be sufficient technical ventilation available, to prevent a dust concentration of greater than 50% of the lower explosion limit (UEG = max. permissible powder/air concentration). If the UEG is not known, then a value of 10 g/m³ should be considered (see EN 50177).

All unauthorized conversions and modifications to the electrostatic spraying equipment are forbidden for safety reasons.

The safety devices may not be dismantled or put out of operation.

Mandatory operational and workplace notices from the operating company must be written in a comprehensible manner in the language of equipment operators and posted in a suitable place.



Slip hazard

Powder lying on the floor around the powder spraying equipment is a potentially dangerous source of slipping. Booths may be entered only in the places designed for this purpose.

Static charges

Static charges can have the following consequences: Charges to people, electric shocks, sparking. Proper grounding must be in place to prevent objects from becoming charged.



Observe the grounding regulations

Earthing

All electrically conductive parts found within 5 meters around each booth opening, and in particular the objects to be coated, must be grounded. The grounding resistance of each object must amount to maximally 1 MOhm. This resistance must be checked/tested regularly when starting work.

The condition of the work piece attachments, as well as the hangers, must guarantee that the work pieces remain grounded. The appropriate measuring devices must be kept ready in the workplace, in order to check the grounding.

The floor of the coating area must conduct electricity (normal concrete is generally conductive).

The supplied grounding cable (green/yellow) must be connected to the grounding screw of the electrostatic manual powder coating equipment. The grounding cable must have a good metallic connection with the coating booth, the recovery unit and the conveyor chain, respectively with the suspension arrangement of the objects.



Fire and smoke prohibition

Smoking and igniting fire are forbidden in the entire vicinity of the system! No work that could potentially produce sparks is allowed!



The stay for persons with cardiac pacemakers is forbidden

As a general rule for all powder spraying installations, persons with pacemakers should never enter high voltage areas or areas with electromagnetic fields. Persons with pacemakers should not enter areas with powder spraying installations!



Photographing with flashlight is forbidden

Photographing with flashlight can lead to unnecessary releases and/or disconnections by safety devices.



Disconnect from mains before maintenance works take place

Disconnect the plugs before the machines are opened for maintenance or repair.

The plug connections between the powder spraying equipment and the mains should only be removed when the power supply is switched off.



As far as it is necessary, the operating firm must ensure that the operating personnel wear protective clothing (e.g. facemasks).

A dust mask corresponding to filter class FFP2 at minimum must be worn during any cleaning work.



The operating personnel must wear electrically conductive, steel-toe footwear (e.g. leather soles).



The operating personnel should hold the gun with bare hands. If gloves are worn, these must also conduct electricity.

These general safety regulations must be read and understood in all cases prior to start-up!

Proper use

1. The OptiFlex 2 Q manual coating equipment is state of the art equipment that conforms to the recognized technical safety regulations and is designed for normal powder coating applications.
2. Any other use is considered non-compliant. The manufacturer shall not be liable for damage resulting from such use; the user bears sole responsibility for such actions. Gema Switzerland GmbH must be consulted before OptiFlex 2 Q manual coating equipment is used for any other purposes or substances beyond those indicated here.
3. Observance of the operating, service and maintenance instructions specified by the manufacturer is also part of conformity of use. The OptiFlex 2 Q manual coating equipment should only be used, maintained and started up by trained personnel informed and familiar with the possible hazards involved.
4. Start-up (i.e. operation of its intended use) is not allowed until it has been established that the OptiFlex 2 Q manual coating equipment has been installed and wired according to the EU Machinery Directive (2006/42/EC). EN 60204-1 (machine safety) must also be observed.
5. Unauthorized modifications to the OptiFlex 2 Q manual coating equipment exempt the manufacturer from any liability from resulting damage.
6. The relevant accident prevention regulations, as well as other generally recognized safety regulations, occupational health and structural regulations are to be observed.
7. Furthermore, the country-specific safety regulations also must be observed.

Product-specific safety measures

- Installation work performed by the customer must be carried out according to local regulations.
- All components must be grounded according to the local regulations before start-up.

OptiFlex 2 Q Manual coating equipment

The OptiFlex 2 Q manual coating equipment is a constituent part of the equipment and is therefore integrated in the system's safety concept.

If it is to be used in a manner outside the scope of the safety concept, then corresponding measures must be taken.



NOTE:

For further security information, see the more detailed Gema safety regulations!

About this manual

General information

This operating manual contains all important information required to work with the OptiFlex 2 Q manual coating equipment. It will safely guide you through the start-up process and give you references and tips for the optimal use of your new powder coating system.

Information about the functionality of the individual system components - booth, gun control unit, manual gun or powder injector - should be referenced to their enclosed corresponding documents.



NOTE:

This operating manual describes all options and functions of this manual coating equipment.

- ▶ Please note that your manual coating equipment may not be equipped with all described functions.
- ▶ Options are marked by double asterisks**.



DANGER:

Working without operating instructions

Working without operating instructions or with individual pages from the operating instructions may result in damage to property and personal injury if relevant safety information is not observed.

- ▶ Before working with the device, organize the required documents and read the section "Safety regulations".
 - ▶ Work should only be carried out in accordance with the instructions of the relevant documents.
 - ▶ Always work with the complete original document.
-

Product description

Field of application

The OptiFlex 2 Q (with powder box) manual coating equipment is exclusively intended for electrostatic coating using organic powders (For more on this please also review chapter "Technical Data").

Any other use is considered non-compliant. The manufacturer is not responsible for any incorrect use and the risks associated with such actions are assumed by the user alone!

For a better understanding of the interrelationships in powder coating, it is recommended that the operating instructions for all other components be read as well, so as to be familiar with their functions too!



OptiFlex 2 Q Manual coating equipment

Utilization

The electrostatic OptiFlex 2 Q manual coating equipment with the OptiSelect GM03 manual powder gun is ideally suited for manual coating of objects.

Reasonably foreseeable misuse

- Operation without the proper training
- Use with insufficient compressed air quality and grounding
- Use in connection with unauthorized coating devices or components

Technical data

Connectable guns

| OptiFlex 2 Q | connectable |
|-----------------|-------------|
| OptiSelect GM03 | yes |



WARNING:

The OptiFlex 2 Q manual coating equipment can only be used with the specified gun type!



Powder output (guide values)

General conditions for the OptiFlow Injector

| Powder type | Epoxy/polyester |
|-----------------------------|----------------------------------|
| Powder hose length (m) | 6 |
| Powder hose Ø (mm) | 10 |
| Power hose type | POE with guide strips |
| Input pressure (bar) | 5.5 |
| Conveying air nozzle Ø (mm) | 1.6 |
| Correction value C0 | Powder output zeroing adjustment |

Guide values for OptiStar CG13 with OptiFlow Injector IG06

All values in these tables are guide values. Differing environmental conditions, wear and different powder types can affect the table values.

| Total air  | | 3 Nm ³ /h | 4 Nm ³ /h | 5 Nm ³ /h |
|---|-----|----------------------|----------------------|----------------------|
| Powder output (g/min) | | | | |
| Powder output  (%) | 20 | 85 | 100 | 120 |
| | 40 | 150 | 185 | 210 |
| | 60 | 210 | 255 | 280 |
| | 80 | 270 | 320 | 350 |
| | 100 | 300 | 360 | 395 |

Air flow rates

The total air consists of conveying air and supplementary air, in relation to the selected powder quantity (in %). As a result the total air volume is maintained constant.

| OptiFlex 2 Q | Range | Factory setting |
|--|----------------------------|------------------------|
| Flow rate - fluidizing air - OptiFlex 2 Q | 0-1.0 Nm ³ /h | 0.1 Nm ³ /h |
| Electrode rinsing air flow rate | 0-3.0 Nm ³ /h | 0.1 Nm ³ /h |
| Flow rate total air (at 5.5 bar) | 1.8-6.5 Nm ³ /h | |



NOTE:

The total air consumption for the device is determined based on the 3 configured air values.

These values apply for an internal control pressure of 5.5 bar!



Electrical data

| OptiFlex 2 Q | |
|--|--|
| Nominal input voltage | 100-240 VAC |
| Frequency | 50-60 Hz |
| Connected load (without vibrator) | 140 VA |
| Nominal output voltage (to the gun) | eff. 10 V |
| Nominal output current (to the gun) | max. 1.2 A |
| Connection and output for vibrator (on Aux output) | 110/230 VAC max. 100 W |
| Connection for rinsing function (valve) | 24 VDC max. 3 W |
| Temperature range | 0 °C - +40 °C (+32 °F - +104 °F) |
| Max. surface temperature | 120 °C (+248 °F) |
| Approvals |   II 3 D IP54 120 °C |

Pneumatic data

| OptiFlex 2 Q | |
|--|-----------------------|
| Max. input pressure | 10 bar |
| Min. input pressure | 6 bar |
| Input pressure (Dynamic based on pressure regulator setting) | 5.5 bar / 80 psi |
| Max. water vapor content of the compressed air | 1.3 g/m ³ |
| Max. oil vapor content of the compressed air | 0.1 mg/m ³ |
| Max. compressed air consumption | 8 Nm ³ /h |

Dimensions

| OptiFlex 2 Q | |
|--------------|---------|
| Width | 460 mm |
| Depth | 862 mm |
| Height | 1105 mm |
| Weight | 42 kg |

Processible powders

| OptiFlex 2 Q | |
|-----------------|-----|
| Plastic powder | yes |
| Metallic powder | yes |
| Enamel powder | no |

Design and function

General view

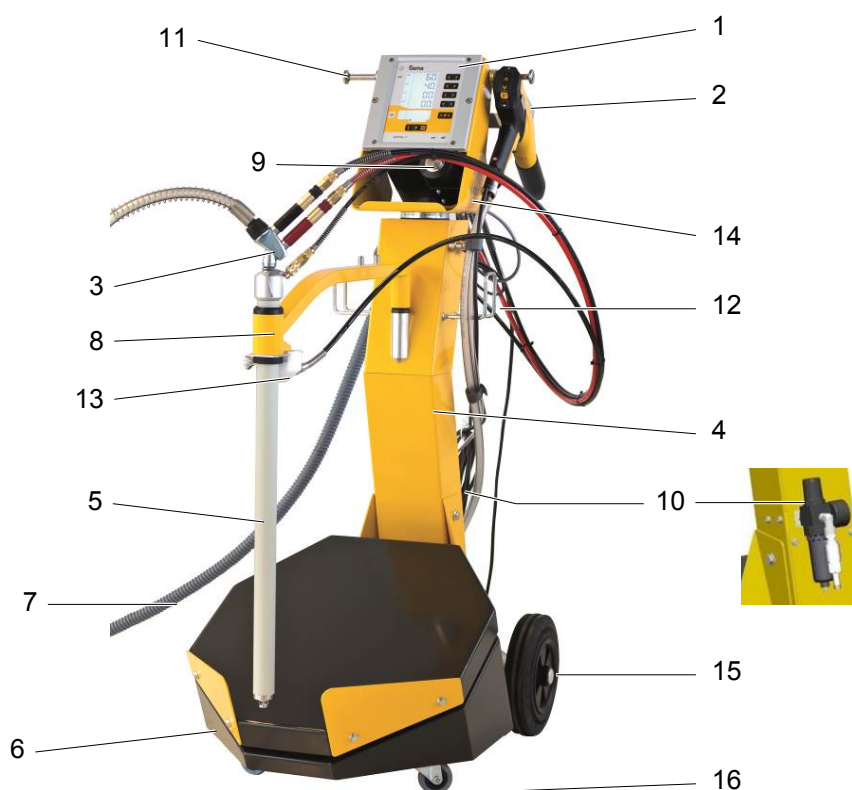

OptiFlex 2 Q manual coating equipment - Setup

- | | | | |
|---|-----------------------------------|----|------------------------------|
| 1 | OptiStar CG13 Gun control unit | 9 | QuickClean button |
| 2 | OptiSelect GM03 manual powder gun | 10 | Filter unit |
| 3 | OptiFlow injector | 11 | Gun holder |
| 4 | Mobile frame with hand rail | 12 | Hose holder |
| 5 | Fluidizing/suction unit | 13 | Cleaning module (QuickClean) |
| 6 | Vibrating table | 14 | Shelf |
| 7 | Venting hose | 15 | Rubber wheel |
| 8 | Swivel arm with guide sleeve | 16 | Swivel wheel |

OptiSelect GM03 manual powder gun

All information about the OptiSelect GM03 manual powder gun can be found in the documentation for that equipment (enclosed with this manual)!

OptiStar CG13 Gun control unit

All information about the OptiStar CG13 Control unit will be found in the corresponding enclosed documentation!

OptiFlow injector

All information about the OptiFlow injector can be found in the corresponding enclosed documentation!

Scope of delivery

OptiFlex 2 Q

- OptiSelect GM03 manual powder gun with gun cable, powder hose, rinsing air hose and standard nozzle set (For more on this, see the operating manual for the OptiSelect GM03 manual powder gun)
- OptiStar CG13 Control unit in a metal case with power supply cable
- plug-in OptiFlow injector
- mobile trolley with a gun/hose support
- vibrating base and a fluidizing/suction unit
- Pneumatic hoses for conveying air (red), supplementary air (black), fluidizing air (black) and rinsing air (black)
- Operating manual
- Short instructions

Typical properties – Characteristics of the functions

Processing the powder directly from the original powder manufacturer's container

The OptiFlex 2 Q manual coating equipment allows for powder to be processed directly out of the original powder manufacturer's container. A tilted vibrating floor has been included to ensure that the powder container empties itself completely.

Freely rotating head piece

The OptiFlex 2 Q manual coating equipment features a freely rotating and lockable head piece for more ergonomic operation and configuration.



Freely rotating head piece

Commissioning

Preparation for start-up

Basic conditions

When starting up the OptiFlex 2 Q manual coating unit, the following general conditions impacting the coating results must be taken into consideration:

- Manual coating equipment is set up properly
- Gun control unit correctly connected
- Gun correctly connected
- Corresponding power and compressed air supply available
- Powder preparation and powder quality

Set-up

The OptiFlex 2 Q manual coating equipment should always be set up vertically on a flat surface.



WARNING:

The manual coating equipment must not under any circumstances be set up near a heat source (such as an enameling furnace) or an electromagnetic source (such as a control cabinet).

Mounting instructions

The OptiFlex 2 Q manual coating equipment must be set up in accordance with the setup and connecting instructions (included with delivery).



OptiFlex 2 Q Manual coating equipment

Connection instructions

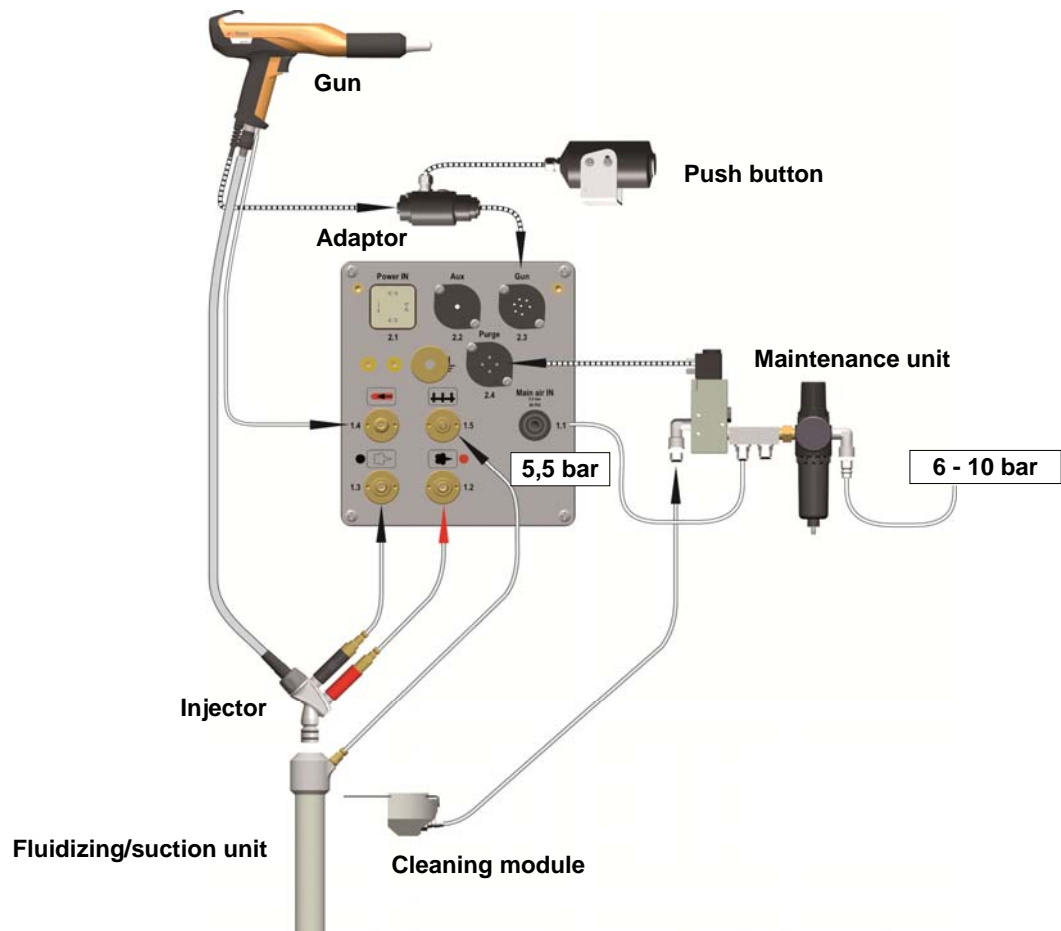

Connection instructions - overview

The OptiFlex 2 Q manual coating equipment must be connected in accordance with the setup and connection instructions (Please also review the operating instructions for the OptiStar CG13 manual gun control unit).

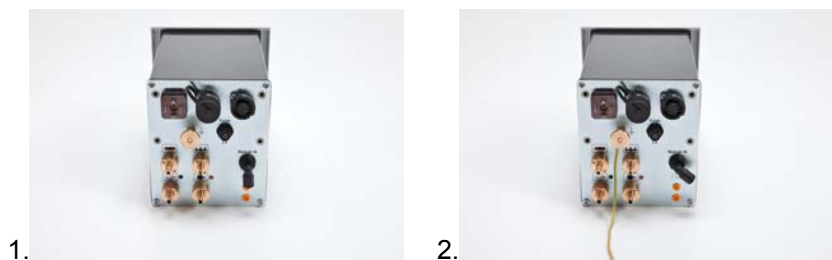



NOTE:

Use clamp to connect grounding cable to the cabin or the suspension arrangement. Check ground connections with Ohm meter and ensure 1 MOhm or less!

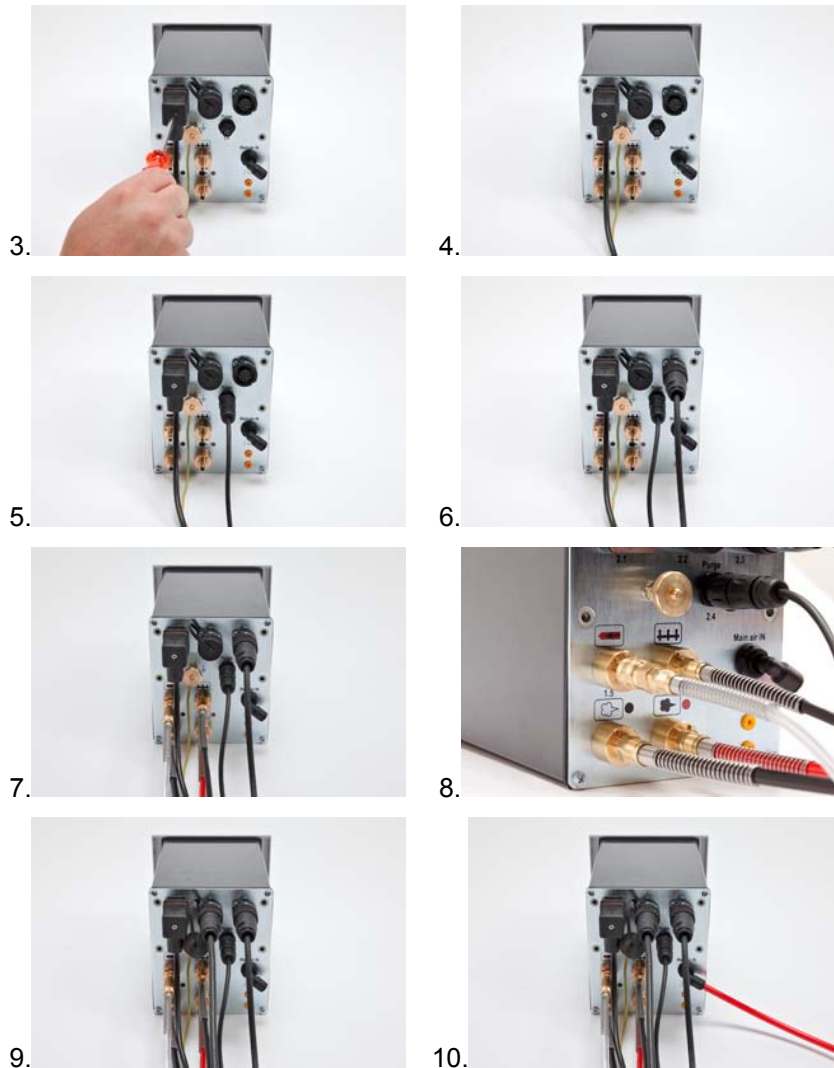

NOTE:

The compressed air must be free of oil and water!

Initial start-up



NOTE:

If a malfunction occurs, see the troubleshooting guide, as well as the gun control unit operating manual!

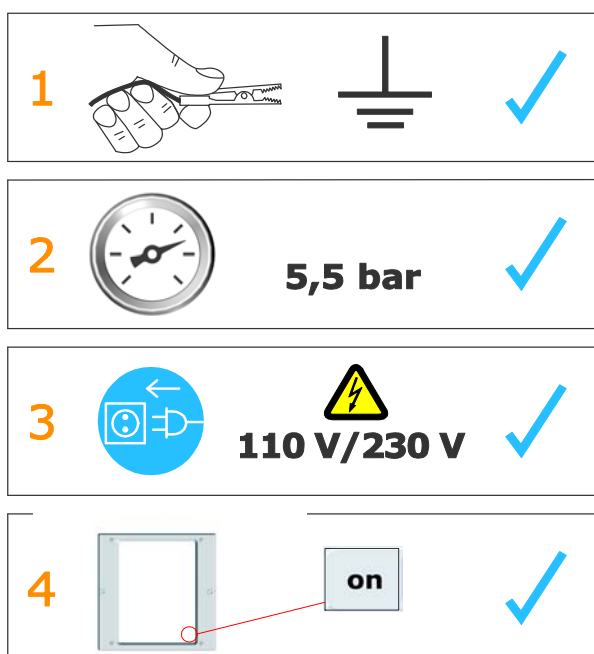

NOTE:

The remainder of the start-up procedure for the OptiSelect GM03 manual powder gun is explicitly described in the operating instructions for the OptiStar CG13 manual powder gun control unit (chapter "Initial start-up" and "Daily start-up")!

Set head piece

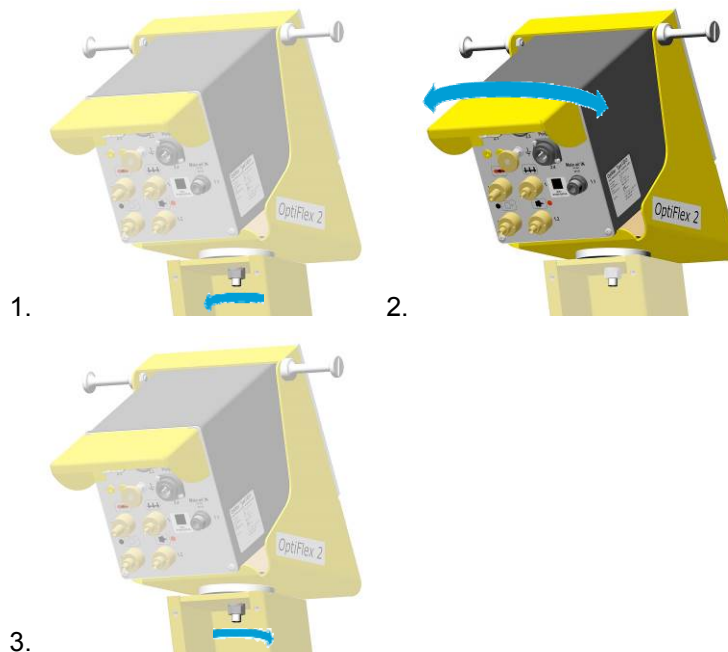

Setting the device type



NOTE:

If the control unit is delivered as a integral component of an OptiFlex apparatus, then the system parameters will have been factory preconfigured for optimal use (For more on this, please also see the operating instructions for the OptiStar CG13 manual gun control unit)!



NOTE:

The manual gun control unit always starts up to the last configured settings.

Operation

Coating



WARNING:

If the manual equipment is not being used for coating in conjunction with a sufficiently powerful suction unit, then the stirred-up dust from the coating powder can cause respiratory issues or cause a slippage/falling hazard.

- ▶ The manual equipment may only be operated in conjunction with a sufficiently powerful suction unit (such as Gema Classic Open booth).

1. Turn on the gun control unit with the **ON** key
The displays illuminate and the control unit is ready for operation
2. Swivel aside the fluidizing/suction unit
3. Place the open powder container on the vibrating table





WARNING:

If a container is placed on the vibrating plate, then fingers caught in the gap between the two plates can be crushed.

- ▶ The container may weight a max. of 30 kg.

4. Place the fluidizing/suction unit onto the powder
5. Set coating parameters:
6. Press the application button for the appropriate preset mode:

| | |
|-------------------|---|
| flat parts |  |
| complicated parts |  |
| overcoat |  |

The arrow above the desired button lights up



OR

7. Press  program key
 - a) Select desired program (01-20)

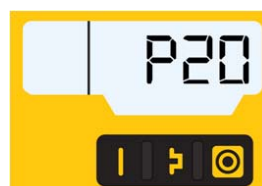

- b) Change coating parameters as required



NOTE:

Programs 01-20 are preset at the factory but can be modified at any time, after which they are automatically stored.

| Description | Presetting |
|-------------------------|------------------------|
| Powder output | 50% |
| Total air | 4.0 Nm ³ /h |
| High voltage <i>kV</i> | 80 kV |
| Spray current <i>μA</i> | 80 μA |
| Electrode rinsing air | 0.1 Nm ³ /h |
| Fluidizing air | 0.1 Nm ³ /h |

8. Setting the total air volume

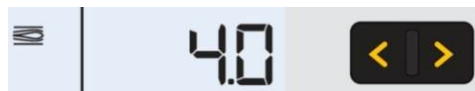

correct powder cloud



too little total air



NOTE:

A total air volume of 4 Nm³/h and a 50% powder share are recommended as the base values.

9. Adjust the powder output volume (e.g. according to the desired coating thickness)



much powder



little powder

**NOTE:**

To achieve maximum efficiency, we recommend avoided an overly high powder volume where possible!

- ▶ The standard setting of 50% and a total air volume of 4 Nm³/h is recommended at the start. The total air volume is thereby kept constant automatically by the control unit.
- ▶ If values are entered that the equipment cannot implement, then the operator is informed of this by a blinking in the relevant display and a temporary error message!

10. Setting the electrode rinsing air

- a) Press the key  The second display level will be shown

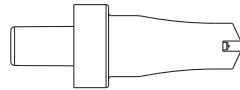

approx.
0.1 Nm³/h

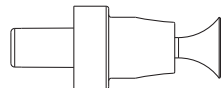

approx.
0.5 Nm³/h



too much electrode rinsing air

11. Setting the fluidization

- a) Press the key  The second display level will be shown



- c) Check the powder fluidization in the powder container. The powder fluidization in the powder containers depends on the powder characteristic, the humidity and the ambient air temperature. Fluidizing and vibration start by switching on the control unit.

**WARNING:**

If the fluidization has been incorrectly adjusted, then the coating powder can create a dust cloud capable of causing respiratory problems.

- ▶ Adjust the fluidization correctly

12. Point the gun into the booth (not at the object to be coated), press the gun trigger and visually check the powder output
13. Check whether everything is functioning correctly
14. Coating

15. Adjust the coating parameters as necessary
16. Activate the rinsing function periodically



NOTE:

It prevents the bridging phenomena that can lead to short circuiting when handling powders such as metallic powders.

In moist or tropical environments, any moisture is driven from the injector, powder hose and powder gun.

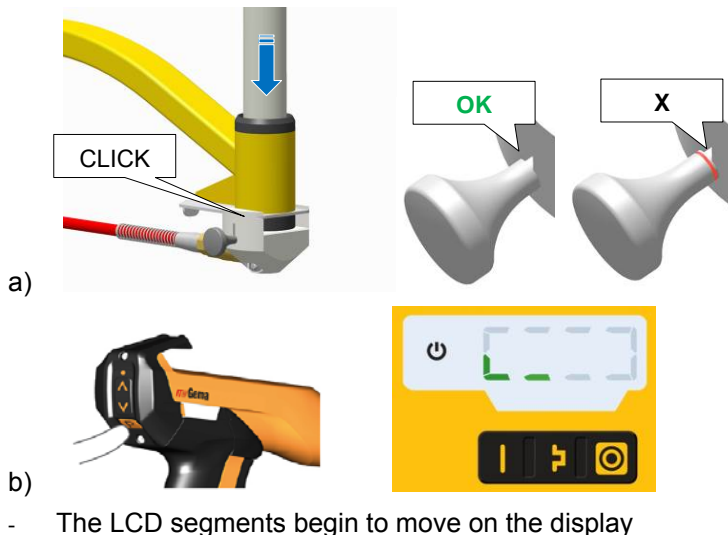

NOTE:

The rinsing function can be stopped as required using the P key.





| Procedure | Effect |
|-----------|---|
| automatic | <ul style="list-style-type: none"> - The automatic rinsing process is started - Injector, powder hose, gun and spray nozzle are purged using compressed air - The automated PowerClean function enables parallel cleaning of other components, such as the fluid intake unit, powder container, etc. |
| manual | <ul style="list-style-type: none"> - The operator controls the number and length of the PowerClean impulse by pressing the pistol trigger a second time |

After completion of the PowerClean procedure, the controller switches back to coating mode.

Setting the background illumination

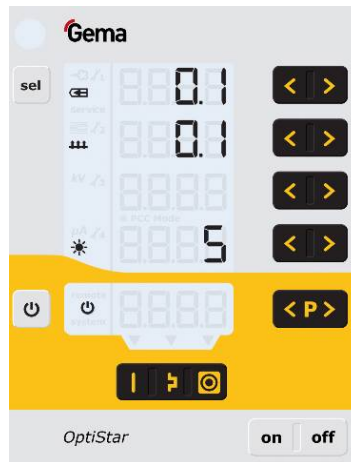
1. Press  key
The display switches to the following level:



2. 
Select the desired brightness

Color change

General information

When a color change takes place, the automatic cleaning process is started from the gun or by activating the remote button on the control module. All components that contain powder – from the suction tube, to the injector, powder hose, through to the gun and spray nozzle – are automatically and comprehensively cleaned with pulses of compressed air.

The powerful air mover, installed in the frame of the trolley automatically cleans the suction tube as it is raised. The powder dust that is removed is extracted to the booth via an exhaust hose..



1.



2.

3. Point the gun into the booth

4. Check, if the exhaust hose is connected to the booth.

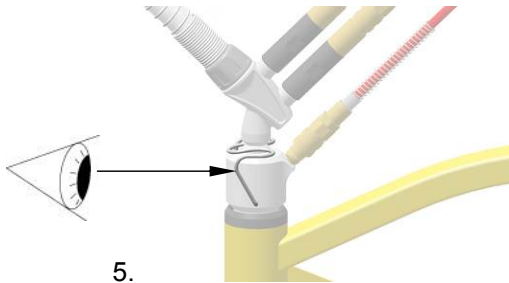

5.

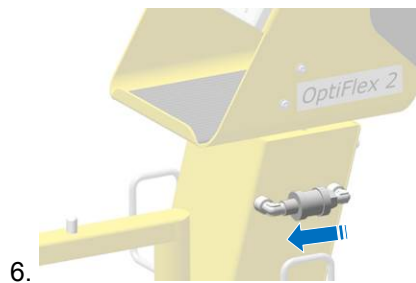

6.



7.



8.

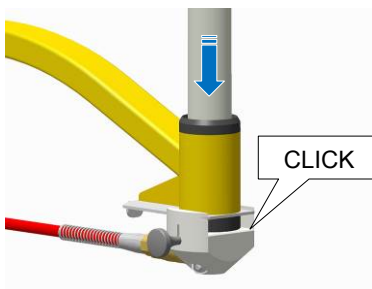

9.

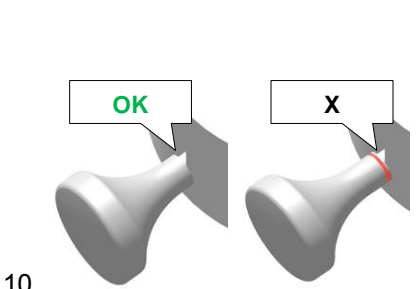

10.

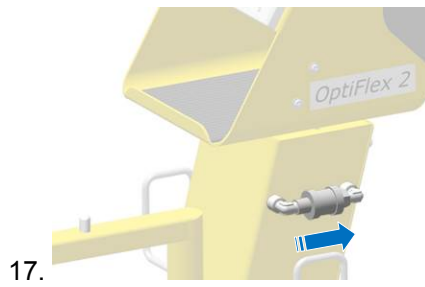

Shutdown

1. Release gun trigger
2. Switch off the control unit



NOTE:

The adjustments for high voltage, powder output, electrode rinsing air and fluidizing remain stored!

If in disuse for several days

1. Separate from power mains
2. Clean the coating equipment (see the corresponding operating manual)
3. Turn off the compressed air main supply

Cleaning and maintenance



NOTE:

Regular and conscientious maintenance increases the service life of the OptiFlex 2 Q manual coating equipment and provides for a longer continuous coating quality!

- ▶ The parts, which are to be replaced during maintenance work, are available as spare parts. These parts will be found in the corresponding spare parts list!
-

Daily maintenance

1. Clean the injector (see therefore the user manual of the OptiFlow injector)
2. Clean the powder gun (For more on this, please also review the user manual for the OptiSelect GM03 manual powder gun)
3. Clean the powder hose; Please also review the section "Color change"

Weekly maintenance

1. Clean fluidizing/suction unit, injector and powder gun. The fluidizing/suction unit is placed back into the powder shortly before restarting operation
2. Check the control unit grounding connections to the coating booth, the suspension devices of the work pieces, or the conveyor chain

If in disuse for several days

1. Separate from power mains
2. Clean the coating equipment
3. Turn off the compressed air main supply

Powder hose rinsing

If longer downtimes take place, the powder hose has to be cleaned.

Procedure:

1. Disconnect the powder hose from the hose connection on the injector
2. Point the gun into the booth

3. Blow through the hose manually with a compressed air gun
4. Connect the powder hose again to the hose connection on the injector

Cleaning



WARNING:

If no dust mask or one of an insufficient filter class is worn when cleaning the manual equipment, then the dust that is stirred up from the coating powder can cause respiratory problems.

- ▶ The ventilation system must be turned on for all cleaning work.
 - ▶ A dust mask corresponding to filter class FFP2 at minimum must be worn during any cleaning work.
-

Cleaning the fluidizing/suction unit

1. Remove the injector
2. Remove the fluidizing/suction unit
3. Clean the fluidizing/suction unit with compressed air. Also blow off the suction tube with compressed air
4. Clean the injector (see therefore the injector user manual)
5. Reassemble the individual parts

Cleaning the OptiSelect GM03 manual powder gun

Frequent cleaning of the gun helps to guarantee the coating quality.



NOTE:

Before cleaning the powder gun, switch off the control unit. The compressed air used for cleaning must be free of oil and water!

Daily:

1. Blow off the outside of the gun and wipe, clean etc.

Weekly:

2. Remove the powder hose from the connection
3. Remove the spray nozzle from the gun and clean it
4. Blow out the gun from the connection in flow direction with compressed air
5. Clean the integrated gun tube with the provided gun brush
6. Blow through the gun with compressed air again
7. Clean the powder hose
8. Reassemble the gun and connect it



NOTE:

Please also review the user manual for the OptiSelect GM03 manual powder gun!

Maintenance and cleaning of the filter unit

The filter unit on the OptiFlex 2 Q manual coating equipment measures and cleans the compressed air. This is where the equipment's main compressed air connection is located.

Replacing the filter element

Procedure:

1. Unscrew the filter glass on the filter unit
2. Remove the complete filter element

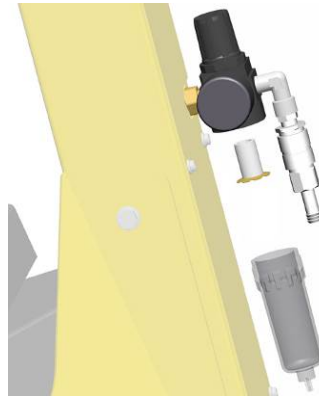

3. Replace the filter element
4. Clean the filter glass on the inside and install it again

Fault remedying

General information



NOTE:

Prior to any troubleshooting measures, always check whether the equipment parameters (P00) as configured in the control unit are correct (See operating instructions for the OptiStar CG13 manual gun control unit, Chapter "Initial Start-up – Setting Equipment Type")

| Fault | Causes | Fault remedying |
|--|---|--|
| Control unit displays remain dark, although the control unit is switched on | Control unit is not connected to the mains | Connect the equipment with the mains cable |
| | Power pack fuse defective | Replace the fuse |
| | Power pack defective | Contact local Gema representative |
| The gun does not spray powder, although the control unit is switched on and the gun trigger is pressed | Compressed air not present | Connect the equipment to the compressed air |
| | Injector, throttle motor or nozzle on injector, powder hose or powder gun are clogged | Clean the corresponding part |
| | Insert sleeve in the injector is clogged | Replace |
| | Insert sleeve is not installed | Mount insert sleeve |
| | Fluidization not running | see below |
| | Total air incorrectly configured | Set total air correctly (Default value 4 Nm ³ /h) |
| | Main valve defective | Replace main valve |
| Gun LED remains dark, although the gun is triggered | Gun not connected | Connect the gun |
| | Gun plug, gun cable or gun cable connection defective | Contact local Gema representative |
| | Remote control on powder gun defective | Contact local Gema representative |

| Fault | Causes | Fault remedying |
|---|---|---|
| Powder does not adhere to object, although the gun is triggered and sprays powder | The objects are improperly or insufficiently grounded | Check grounding, reground at better quality |
| | High voltage and current deactivated | Press the selection key (application key) |
| | High voltage cascade defective | Contact local Gema representative |
| The powder is not fluidized | Compressed air not present | Connect the equipment to the compressed air |
| | Fluidizing air is set too low on the control unit | Set the fluidizing air correctly |
| | Throttle motor defective | Contact local Gema representative |
| No electrode rinsing air | Rinsing air throttle motor defective | Contact local Gema representative |
| Vibrator not functioning | Vibrator/condenser broken | Contact local Gema representative |
| | Vibrator not plugged in | plug in |
| | Incorrect equipment type configured | Configure parameter P00 (See operating instructions for the OptiStar CG13 manual gun control unit, Chapter "Initial Start-up – Setting Equipment Type") |

Spare parts list

Ordering spare parts

When ordering spare parts for powder coating equipment, please indicate the following specifications:

- Type and serial number of your powder coating equipment
- Order number, quantity and description of each spare part

Example:

- **Type** OptiFlex 2 Q
Serial number 1234 5678
- Order no. 203 386, 1 piece, Clamp - Ø 18/15 mm

When ordering cable or hose material, the required length must also be given. The spare part numbers of this bulk stock is always marked with an *.

Wearing parts are always marked with a #.

All dimensions of plastic hoses are specified with the external and internal diameter:

Example:

Ø 8/6 mm, 8 mm outside diameter (o/d) / 6 mm inside diameter (i/d)



WARNING!

Only original Gema spare parts should be used, because the explosion protection will also be preserved that way. The use of spare parts from other manufacturers will invalidate the Gema guarantee conditions!

OptiFlex 2 Q - Spare parts list

| | | |
|-----|---|-----------|
| 1 | CG13 gun control unit – complete (see corresponding operating manual) | 1009 971 |
| 2 | GM03 manual powder gun – complete (see corresponding user manual) | 1008 070 |
| 3 | IG06 injector – complete (see corresponding user manual) | 1007 780 |
| 4 | Pneumatic connection for conveying air – complete (incl. Pos. 4.1, 4.2, 4.3) | |
| 4.1 | Quick release connection – NW5, Ø 8 mm, red | 261 645 |
| 4.2 | Nut with kink protection – M12x1 mm, Ø 8 mm | 201 316 |
| 4.3 | Plastic tube – Ø 8/6 mm, red | 103 500* |
| 5 | Pneumatic connection for supplementary air - complete (incl. Pos. 5.1, 5.2 and 5.3) | |
| 5.1 | Quick release connection - NW5, Ø 8 mm, black | 261 637 |
| 5.2 | Nut with kink protection – M12x1 mm, Ø 8 mm | 201 316 |
| 5.3 | Plastic tube - Ø 8/6 mm, black | 1008 038* |
| 6 | Cleaning module – complete, left | 1009 653 |
| 7 | Pneumatic connection for QuickClean air - complete (incl. Pos. 7.1 and 7.2) | |
| 7.1 | Quick release connection - NW5, Ø 8 mm | 1008 027 |
| 7.2 | Plastic tube - Ø 8/6 mm, black | 103 152* |
| 8 | Fluidizing/suction unit - complete (incl. pos. 8.1) | 1009 679 |
| 8.1 | Gasket NBR45 | 1010 101 |
| 9 | Pneumatic connection for conveying air - complete (incl. Pos. 9.1, 9.2 and 9.3) | |
| 9.1 | Quick release connection - NW5, Ø 6 mm | 200 840 |
| 9.2 | Nut with kink protection – M10x1 mm, Ø 6 mm | 201 308 |
| 9.3 | Plastic tube - Ø 6/4 mm, black | 1001 973 |
| 10 | Pneumatic group – complete (see corresponding spare parts list) | |
| 11 | Quick release connection - NW7.8-Ø 10- Ø 26 mm | 239 267 |
| 12 | Rubber damper - Ø 20x25 mm, M6/2a, 43sh | 246 000 |
| 13 | Hexagon shakeproof nut - M6 | 244 430 |
| 14 | Powder hose – Ø 15/10 mm, 6 m | 1001 673 |
| 15 | Kink protection | 1008 844 |
| 16 | QuickClean push button – complete, incl. cable and adaptor | 1009 669 |
| 17 | Spiral hose – ID 20 mm, 5 m | 1009 650 |
| 18 | Hose clamp - Ø 17-25 mm | 223 085 |
| 19 | Screw – M5x20 mm | 1004 167 |
| 20 | Connector | 1010 062 |
| 21 | AirMover | 1009 649 |
| 22 | Short instructions | 1007 143 |
| 23 | Operating manual | 1010 267 |

* Please indicate length

OptiFlex 2 Q - Spare parts list

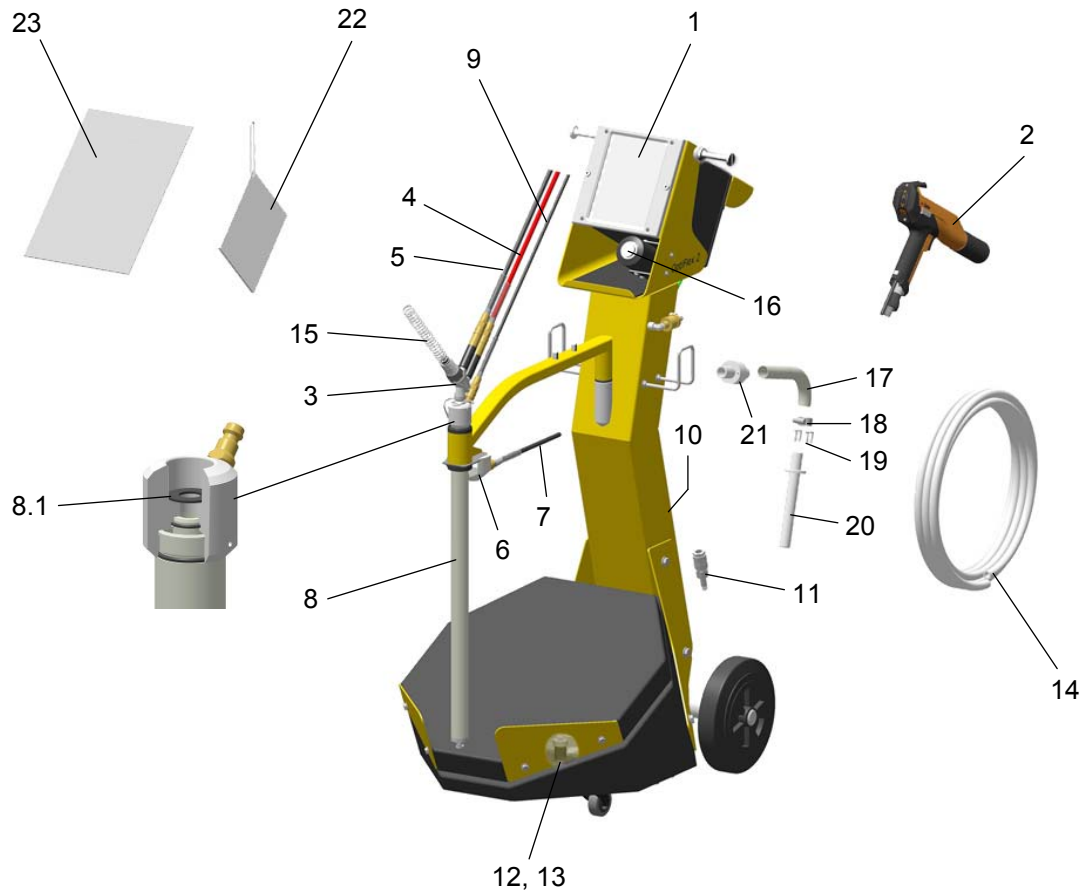

OptiFlex 2 Q manual coating equipment – Spare parts

OptiFlex 2 Q Dual Gun - Spare parts list

| | | |
|---|---|----------|
| 6 | Cleaning module – complete, left | 1009 653 |
| 6.1 | Cleaning module – complete, right | 1009 654 |
| 7 | Pneumatic connection for QuickClean air - complete (incl. Pos. 7.1 and 7.2) | |
| 7.1 | Quick release connection - NW5, Ø 8 mm | 1008 027 |
| 7.2 | Plastic tube - Ø 8/6 mm, black | 103 152* |
| 8 | Fluidizing/suction unit - complete | 1009 679 |
| Pneumatic group – complete (see corresponding spare parts list) | | |

* Please indicate length

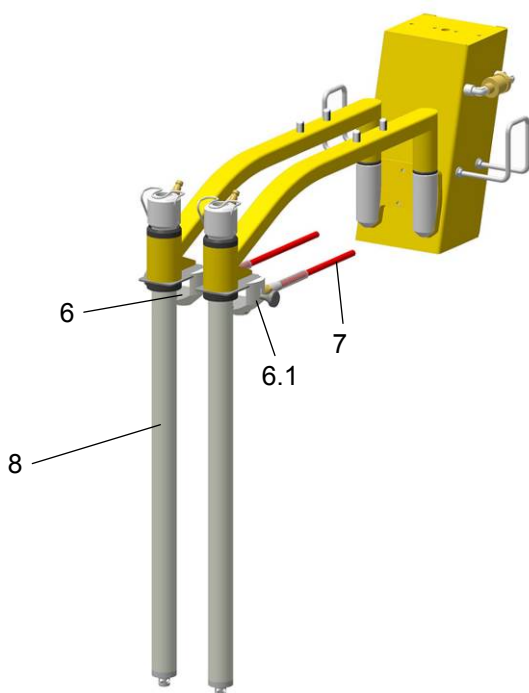

OptiFlex 2 Q - Pneumatic group

| | | |
|---|----------------------------|-----------|
| | Pneumatic group - complete | 1008 235 |
| 1 | Filter cartridge - 20 µm | 1008 239# |
| | # Wearing part | |

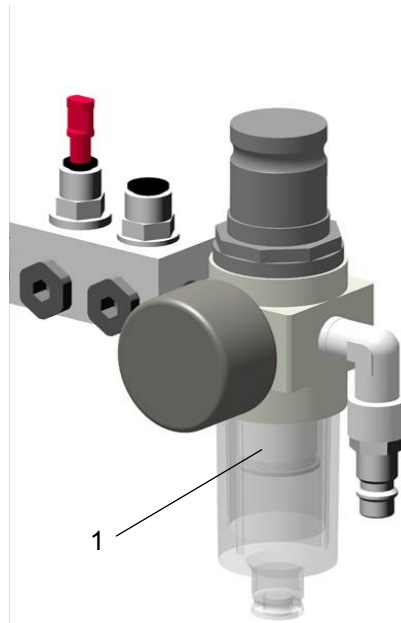

OptiFlex 2 Q - Pneumatic group

OptiFlex 2 Q Dual Gun - Pneumatic group

1 Filter cartridge - 20 µm

1008 239#

Wearing part

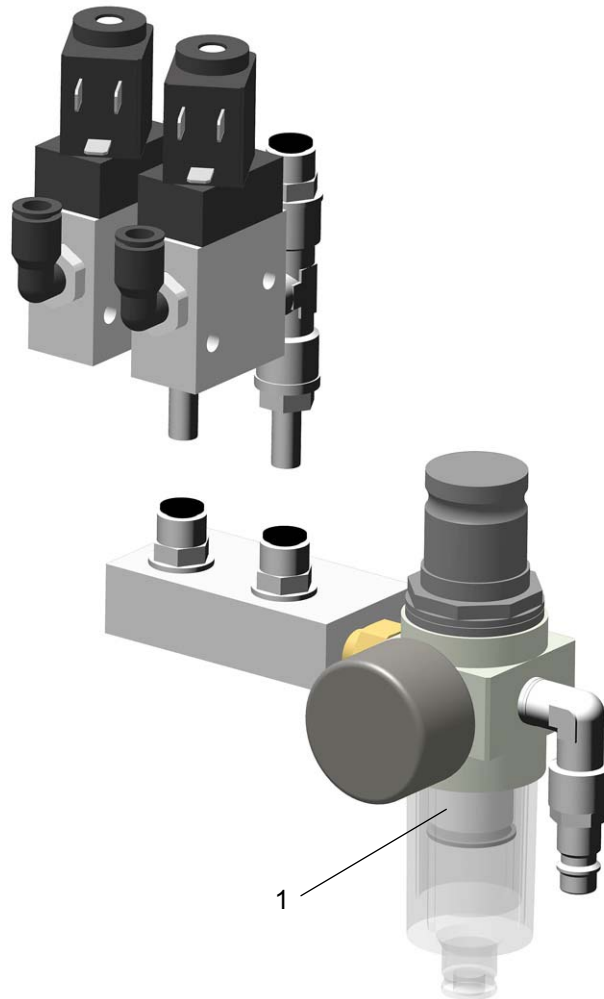

OptiFlex 2 Q Dual Gun - Pneumatic group

