Quick reference guide

Manual equipment OptiFlex 2 F



Translation of the original operating instructions

Documentation OptiFlex 2 F

© Copyright 2016 Gema Switzerland GmbH

All rights reserved.

This publication is protected by copyright. Unauthorized copying is prohibited by law. No part of this publication may be reproduced, photocopied, translated, stored on a retrieval system or transmitted in any form or by any means for any purpose, neither as a whole nor partially, without the express written consent of Gema Switzerland GmbH.

Gema, EquiFlow, MagicCompact, MagicCylinder, OptiCenter, OptiFlex, OptiGun, OptiSelect and OptiStar are registered trademarks of Gema Switzerland GmbH.

ClassicLine, ClassicStandard, ClassicOpen, DVC (Digital Valve Control), GemaConnect, MagicControl, MagicPlus, MonoCyclone, MRS, MultiColor, MultiStar, OptiAir, OptiControl, OptiColor, OptiFeed, OptiFlow, OptiHopper, OptiMove, OptiSieve, OptiSpeeder, OptiSpray, PCC (Precise Charge Control), RobotGun, SIT (Smart Inline Technology) and SuperCorona are trademarks of Gema Switzerland GmbH.

All other product names are trademarks or registered trademarks of their respective holders.

Reference is made in this manual to different trademarks or registered trademarks. Such references do not mean that the manufacturers concerned approve of or are bound in any form by this manual. We have endeavored to retain the preferred spelling of the trademarks, and registered trademarks of the copyright holders.

To the best of our knowledge and belief, the information contained in this publication was correct and valid on the date of publication. Gema Switzerland GmbH makes no representations or warranties with respect to the contents or use of this publication, and reserves the right to revise this publication and make changes to its content without prior notice.

For the latest information about Gema products, visit www.gemapowdercoating.com.

For patent information, see www.gemapowdercoating.com/patents or www.gemapowdercoating.us/patents.

Printed in Switzerland

Gema Switzerland GmbH
Mövenstrasse 17
9015 St.Gallen
Switzerland

Phone: +41-71-313 83 00

Fax.: +41-71-313 83 83

E-mail: info@gema.eu.com

Table of contents

About these instructions	5
General information	5
Keeping the Manual	5
Safety symbols (pictograms).....	5
Presentation of the contents	6
Safety	7
General information	7
Basic safety instructions	7
Product specific security regulations	8
OptiFlex 2 F	13
Structure.....	13
Scope of delivery	14
Technical Data	14
Assembly / Connection	17
Connection instructions.....	17
Set head piece	19
Start-up	21
Initial start-up.....	21
Setting the device type.....	22
Operation	23
Operation	23
Rinsing mode	27
Color change.....	30
Decommissioning / Storage	33
Decommissioning.....	33
Maintenance / Repairs	35
General information	35
Interval	35
Cleaning	37
Fault clearance	39
OptiStar CG13	41
Design and function	41

Fault clearance	45
Error diagnosis of the software.....	45
OptiSelect GM03	49
Structure	49
Scope of delivery	50
Available accessories**	50
Technical Data.....	51
Fault clearance	53
OptiFlow IG06	55
Structure	55
Powder volume setting for OptiFlow Injector.....	56
Maintenance / Repairs	57
Cleaning.....	57
Cleaning the injector.....	57
Cleaning the check valve units.....	58
Replacing the insert sleeve	59
Fault clearance	61
Faults	61
Spare parts list	63
Ordering spare parts.....	63
OptiFlex 2 F – Spare parts list	64
OptiFlex 2 F – Spare parts	65
Pneumatic group	66
PowerClean module set**.....	67
OptiStar CG13 Gun control unit.....	68
Front plate and power pack.....	69
Inside back plate.....	70
Connecting material.....	71
OptiSelect GM03 – Spare parts list	72
PowerClean™ module (Option).....	74
SuperCorona	75
Accessories	76
OptiFlow IG06 – spare parts list	81
OptiFlow IG06 – spare parts.....	82

About these instructions

General information

This operating manual contains all important information which you require for the working with the OptiFlex 2 F. It will safely guide you through the start-up process and give you references and tips for the optimal use when working with your powder coating system.

Information about the functional mode of the individual system components should be referenced in the respective enclosed documents.



This operating manual describes all options and functions of this manual coating equipment.

- Please note that your manual coating equipment may not be equipped with all described functions.
- Options are marked by double asterisks**.

Keeping the Manual

Please keep this Manual ready for later use or if there should be any queries.

Safety symbols (pictograms)

The following warnings with their meanings can be found in the Gema instructions. The general safety precautions must also be followed as well as the regulations in the relevant instructions.

DANGER

Indicates a hazardous situation which, if not avoided, will result in death or serious injury.

WARNING

Indicates a hazardous situation which, if not avoided, could result in death or serious injury.

⚠ CAUTION

Indicates a hazardous situation which, if not avoided, could result in minor or moderate injury.

ATTENTION

Indicates a potentially harmful situation. If not avoided, the equipment or something in its surrounding may be damaged.

ENVIRONMENT

Indicates a potentially harmful situation which, if not avoided, may have harmful consequences for the environment.



MANDATORY NOTE

Information which must be observed.



NOTICE

Useful information, tips, etc.

Structure of Safety Notes

Every note consists of 4 elements:

- Signal word
- Nature and source of the danger
- Possible consequences of the danger
- Prevention of the danger

⚠ SIGNAL WORD

Nature and source of the hazard!

Possible consequences of the danger

- ▶ Prevention of the danger

Presentation of the contents

Figure references in the text

Figure references are used as cross references in the descriptive text.

Example:

"The high voltage (**H**) created in the gun cascade is guided through the center electrode."

Safety

General information

This chapter provides the user and third parties who operate this product with all essential safety regulations, the adherence to which is imperative.

These safety regulations must be read and understood in their entirety before the product is put into operation.

The standards and guidelines applied during the development, manufacture and configuration are described in the EC declaration of conformity and in the manufacturer's declaration.

WARNING

Working without instructions

Working without instructions or with individual pages from the instructions may result in damage to property and personal injury if relevant safety information is not observed.

- ▶ Before working with the device, organize the required documents and read the section "Safety regulations".
 - ▶ Work should only be carried out in accordance with the instructions of the relevant documents.
 - ▶ Always work with the complete original document.
-

Basic safety instructions

- This product is built to the latest specification and conforms to the recognized technical safety regulations and is designed for the normal application of powder coating.
- Any other use is considered non-compliant. The manufacturer shall not be liable for damage resulting from such use; the user bears sole responsibility for such actions. If this product is to be used for other purposes or other substances outside of our guidelines then Gema Switzerland GmbH should be consulted.
- Start-up (i.e. the execution of intended operational tasks) is forbidden until it has been established that this product has been set up and wired according to the guidelines for machinery. The standard "Machine safety" must also be observed.
- Unauthorized modifications to the product exempt the manufacturer from any liability from resulting damage.

- The relevant accident prevention regulations, as well as other generally recognized safety regulations, occupational health and structural regulations are to be observed.
- Furthermore, the country-specific safety regulations also must be observed.

Product specific security regulations

- This product is a constituent part of the equipment and is therefore integrated in the system's safety concept.
- If it is to be used in a manner outside the scope of the safety concept, then corresponding measures must be taken.
- The installation work to be done by the customer must be carried out according to local regulations.
- It must be ensured, that all components are earthed according to the local regulations before start-up.



For further security information, see the more detailed Gema safety regulations!

WARNING

These general safety regulations must be read and understood in all cases prior to start-up!



General information

This product is built to the latest specification and conforms to the recognized technical safety regulations and is designed for the normal application of powder coating.

Any other use is considered non-compliant. The manufacturer shall not be liable for damage resulting from such use; the user bears sole responsibility for such actions. If this product is to be used for other purposes or other substances outside of our guidelines then Gema Switzerland GmbH should be consulted.

Observance of the operating, service and maintenance instructions specified by the manufacturer is also part of conformity of use.

The relevant accident prevention regulations, as well as other generally recognized safety regulations, occupational health and structural regulations are to be observed.

Furthermore, the country-specific safety regulations also must be observed.

Additional safety and operation notices can be found on the accompanying CD or on the homepage www.gemapowdercoating.com.



General dangers

Start-up is forbidden until it has been established that the product has been set up and wired according to the EU guidelines for machinery.

Unauthorized modifications to the product exempt the manufacturer from any liability from resulting damages or accidents.

The operator must ensure that all users do have the appropriate training for powder spraying equipment and are aware of the possible sources of danger.

Any operating method, which will negatively influence the technical safety of the powder spraying equipment, is to be avoided.

For your own safety, only use accessories and attachments listed in the operating instructions. The use of other parts can lead to risk of injury. Only original Gema spare parts should be used!

Repairs must only be carried out by specialists or by authorized Gema service centers. Unauthorized conversions and modifications can lead to injuries and damage to the equipment and invalidate the Gema Switzerland GmbH guarantee.



Electrical danger

The connecting cables between the control unit and the spray gun must be installed in such a way, that they cannot be damaged during the operation. Please observe the local safety regulations!

The plug connections between the powder spraying equipment and the mains should only be removed when the power supply is switched off.

All maintenance activities must take place when the powder spraying equipment is switched off.

The product may not be switched on until the booth is in operation. If the booth stops, the product must switch off too.



Explosion hazard

The control units for the spray guns must be installed and used in zone 22. Spray guns are allowed in zone 21.

Only original Gema OEM parts are guaranteed to maintain the explosion protection rating. If damages occur by using spare parts from other manufacturers, the warranty or compensation claim is void!

Conditions leading to dangerous levels of dust concentration in the powder spraying booths or in the powder spraying areas must be avoided. There must be sufficient technical ventilation available, to prevent a dust concentration of more than 50% of the lower explosion limit (UEG = max. permissible powder/air concentration). If the UEG is not known, then a value of 10 g/m³ should be considered (see EN 50177).

All unauthorized conversions and modifications to the electrostatic spraying equipment are forbidden for safety reasons.

No safety devices should be dismantled or put out of operation.

Mandatory operational and workplace notices from the operating company must be written in a comprehensible manner in the language of equipment operators and posted in a suitable place.



Slip hazard

Powder lying on the floor around the powder spraying equipment is a potentially dangerous source of slipping. Booths may be entered only in the places suitable for it.

Static charges

Static charges can have the following consequences: Charges to people, electric shocks, sparking. Proper grounding must be in place to prevent objects from becoming charged.

Grounding

Observe the grounding regulations



All electrically conductive parts found in the workplace of 5 meters around each booth opening, and particularly the objects to be coated, have to be grounded. The grounding resistance of each object must amount to maximally 1 MOhm. This resistance must be checked/tested regularly when starting work.

The condition of the work piece attachments, as well as the hangers, must guarantee that the work pieces remain grounded. The appropriate measuring devices must be kept ready in the workplace, in order to check the grounding.

The floor of the coating area must conduct electricity (normal concrete is generally conductive).

The supplied grounding cable (green/yellow) must be connected to the grounding screw of the electrostatic manual powder coating equipment. The grounding cable must have a good metallic connection with the coating booth, the recovery unit and the conveyor chain, respectively with the suspension arrangement of the objects.

Fire and smoke prohibition



Smoking and open flames

Smoking and igniting fire are forbidden in the entire vicinity of the system! No work that could potentially produce sparks is allowed!

The stay for persons with cardiac pacemakers is forbidden



Stay for persons with cardiac pacemakers

As a general rule for all powder spraying installations, persons with pacemakers should never enter high voltage areas or areas with electromagnetic fields. Persons with pacemakers should not enter areas with powder spraying installations!

**Photographing with
flashlight is forbidden**



Photographing with flashlight

Photographing with flashlight can lead to unnecessary releases and/or disconnections by safety devices.

**Disconnect from mains
before maintenance
works take place**



Maintenance works

Disconnect the plugs before the machines are opened for maintenance or repair.

The plug connections between the powder spraying equipment and the mains should only be removed when the power supply is switched off.



As far as it is necessary, the operating firm must ensure that the operating personnel wear protective clothing (e.g. facemasks).

A dust mask corresponding to filter class FFP2 or N95 at minimum must be worn during any cleaning work.

The operating personnel must wear electrically conductive, steel-toe footwear (e.g. leather soles).

The operating personnel should hold the gun with bare hands. If gloves are worn, these must also conduct electricity.

OptiFlex 2 F



For further information, see the corresponding operating manual, which can be found on the accompanying CD.

Structure

Overall view



fig. 1

- | | | | |
|----|--------------------------------|----|---------------------|
| 1 | OptiStar CG13 Gun control unit | 11 | Gun holder |
| 2 | OptiSelect GM03 manual gun | 12 | Hose holder |
| 3 | OptiFlow injector | 13 | PowerClean module** |
| 4 | Frame | 14 | Shelf |
| 7 | Fluidized powder hopper | 15 | Rubber wheel |
| 8 | AirMover | 16 | Swivel wheel |
| 10 | Filter unit | | |

Scope of delivery

- OptiSelect GM03 manual powder gun with gun cable, powder hose, rinsing air hose and standard nozzle set (For more on this, see the operating manual for the OptiSelect GM03 manual powder gun)
- OptiStar CG13 Control unit in a metal case with power supply cable
- plug-in OptiFlow injector
- mobile trolley with a gun/hose support
- Fluidized powder hopper
- PowerClean module**
- Pneumatic hoses for conveying air (red), supplementary air (black), fluidizing air (black) and rinsing air** (black)
- Operating manual
- Short description

Technical Data



Connectable guns

ATTENTION

The OptiFlex 2 F Manual coating equipment may only be used with the specified gun types!

OptiFlex 2 F	connectable
OptiSelect GM03	yes

Electrical data

OptiFlex 2 F	
Nominal input voltage	100-240 VAC
Frequency	50-60 Hz
Connected load (without vibrator)	40 VA
Nominal output voltage (to the gun)	eff. 10 V
Nominal output current (to the gun)	max. 1.2 A
Connection and output for vibrator (on Aux output)	110/230 VAC max. 100 W
Connection for rinsing function (valve)	24 VDC max. 3 W
Temperature range	0 °C - +40 °C (+32 °F - +104 °F)
Max. surface temperature	120 °C (+248 °F)
Approvals	  II 3 D IP54 120 °C

Pneumatic data

OptiFlex 2 F	
Max. input pressure	10 bar
Min. input pressure	6 bar
Input pressure (Dynamic based on pressure regulator setting)	5.5 bar / 80 psi
Max. water vapor content of the compressed air	1,3 g/m ³
Max. oil vapor content of the compressed air	0,1 mg/m ³
Max. compressed air consumption	11 Nm ³ /h

Dimensions

OptiFlex 2 F	
Width	460 mm
Depth	832 mm
Height	1105 mm
Weight	46 kg

Processible powders

OptiFlex 2 F	
Plastic powder	yes
Metallic powder	yes
Enamel powder	no

Powder output (reference values)

General conditions for the OptiFlow Injector

Powder type	Epoxy/polyester
Length of powder hose (m)	6
Powder hose Ø (mm)	10
Type of powder hose	POE with guide strips
Input pressure (bar)	5.5
Correction value C0	Powder output zeroing adjustment

Guide values for OptiStar CG13 with OptiFlow Injector IG06

All values in these tables are guide values. Differing environmental conditions, wear and different powder types can affect the table values.

Total air		3 Nm ³ /h	4 Nm ³ /h	5 Nm ³ /h
		Powder output (g/min)		
Powder output (%)	20	85	100	120
	40	150	185	210
	60	210	255	280
	80	270	320	350
	100	300	360	395

Air flow rates

The total air consists of conveying air and supplementary air, in relation to the selected powder quantity (in %). As a result the total air volume is maintained constant.

OptiFlex 2 F	Range	Factory setting
Flow rate – fluidizing air:	0-5.0 Nm ³ /h	1.0 Nm ³ /h
Electrode rinsing air flow rate	0-5.0 Nm ³ /h	0.1 Nm ³ /h
Flow rate total air (at 5.5 bar)	5 Nm ³ /h	
– Conveying air flow rate	0-5.4 Nm ³ /h	
– Supplementary air flow rate	0-4.5 Nm ³ /h	

- ▶ **The max. total air consumption during the coating operation is < 5,5 Nm³/h:**
- Total air = 5 Nm³/h (conveying air + supplementary air)
 - Electrode rinsing air = 0,1 Nm³/h (flat jet nozzle)

- ▶ **The total air consumption for the device is determined based on the 3 configured air values (without AirMover air value).**
- These values apply for an internal control pressure of 5.5 bar!

Assembly / Connection

Connection instructions

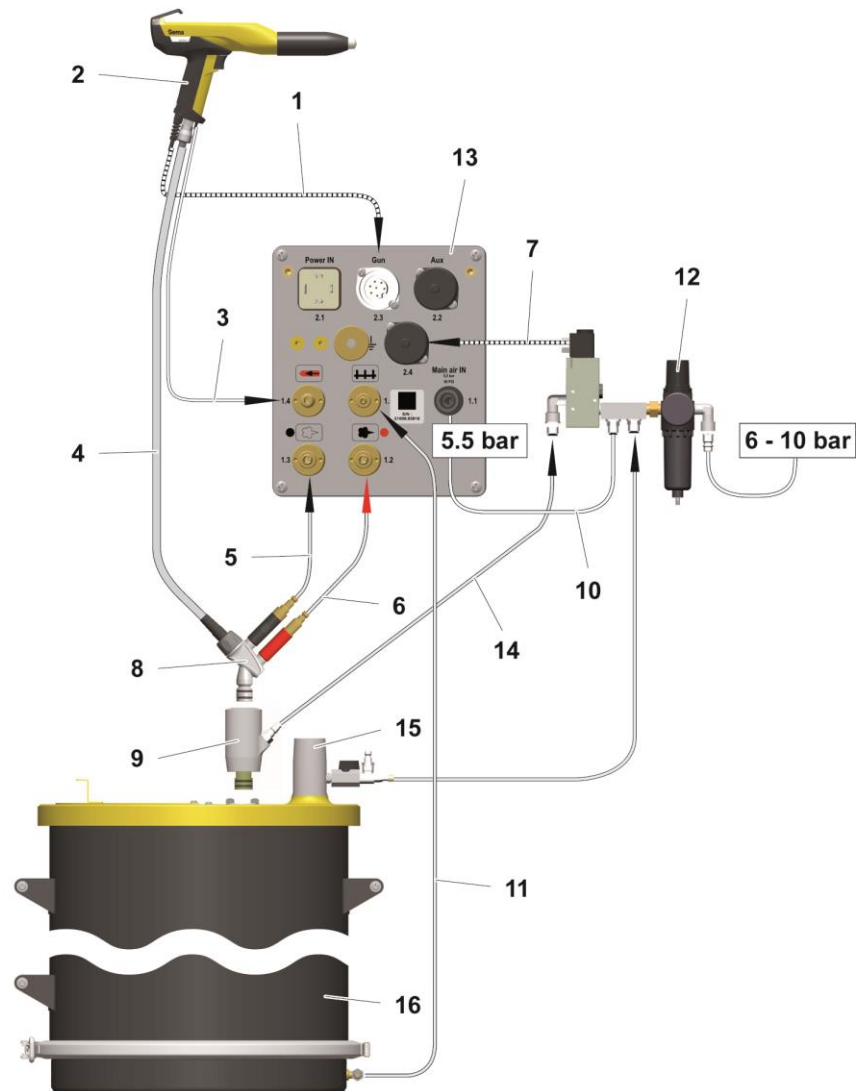

fig. 2: Connecting guide – overview

- | | |
|------------------------------|-------------------------------|
| 1 Electrode rinsing air hose | 9 PowerClean™ module (Option) |
| 2 OptiSelect GM03 manual gun | 10 Compressed air hose |

- | | |
|--------------------------|-----------------------------------|
| 3 Gun cable | 11 Fluidizing air hose |
| 4 Powder hose | 12 Maintenance unit |
| 5 Supplementary air hose | 13 OptiStar CG13 Gun control unit |
| 6 Conveying air hose | 14 Rinsing air hose |
| 7 Control signal cable | 15 AirMover |
| 8 Injector | 16 Fluidized powder hopper |



Use clamp to connect grounding cable to the cabin or the suspension arrangement!

- ▶ Check ground connections with Ohm meter and ensure 1 MOhm or less!



Close the unused connections with the provided dust protection caps!

- ▶ If no vibration motor (OptiFlex B) is connected, close the 2.2 Aux output with the dust protection cap!
- ▶ If no PowerClean module is connected, close also the 2.4 Purge connection with the dust protection cap!



The compressed air must be free of oil and water!





Connections

Compressed air hoses / cables

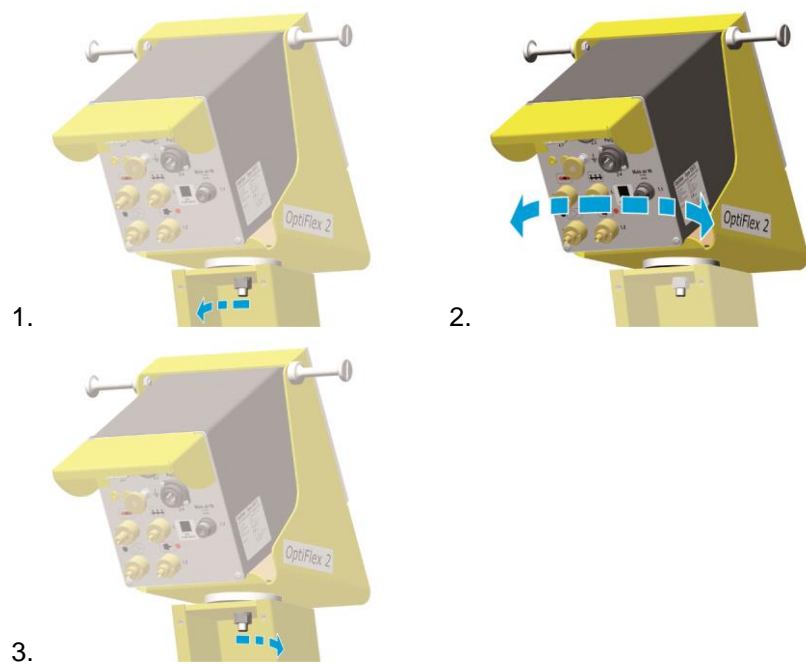

fig. 3: Connections

Connection	Description
1.1 Main air IN	Compressed air connection
2.1 Power IN	Mains cable connection
2.2 Aux	Vibration motor connection for OptiFlex 2 B
2.3 Gun	Gun cable connection

Connection	Description
2.4 Power Clean	Connection to rinsing module
1.2 	Conveying air connection
1.3 	Supplementary air connection
1.4 	Electrode rinsing air connection
1.5 	Fluid air connection
	Grounding connection

Set head piece



Start-up

Initial start-up



If a malfunction occurs, see the troubleshooting guide, as well as the gun control unit operating manual!



Fig. 4



The remainder of the start-up procedure for the Gun is explicitly described in the operating instructions for the OptiStar CG08/CG13 powder gun control unit (chapter "Initial start-up" and "Start-up")!

Setting the device type



If the control unit is supplied as a component of an OptiFlex 2 complete unit, then the corresponding system parameter is set correctly by the factory.

ATTENTION

A wrong parameterization leads to various malfunctions!

- ▶ For more on this, please also see the operating instructions for the OptiStar CG13 gun control unit!
-

Operation

⚠ WARNING

Holding the gun incorrectly

During the coating process, the gun can discharge along the body of the coater if not held using its intended handle, which has been grounded.

- ▶ Always hold gun only by the handle!
- ▶ Do not touch any other parts of the gun!

Operation

⚠ CAUTION

Large dust formation possible!

If the manual equipment is not being used for coating in conjunction with a sufficiently powerful suction unit, then the stirred-up dust from the coating powder can cause respiratory issues or cause a slippage/falling hazard.

- ▶ The manual equipment may only be operated in conjunction with a sufficiently powerful suction unit (such as Gema Classic Open booth).

1. Place powder hopper on the mobile trolley

⚠ CAUTION

Foot injury!

When setting the powder hopper onto the mobile trolley of the manual equipment, the hopper/trolley zone represents a threat of crushed toes

- ▶ Wear safety shoes with steel toecaps.

2. Set the ventilation (Airmover)
 - Open the ball valve completely
 - Calibrate with the throttle valve
3. Fill in powder
 - Open the powder hopper filling cover.
 - Fill in powder: Fill with maximum 25 kg (50 l) powder or the powder must reach to a maximum of 5-10 cm below the handles

of the powder hopper; otherwise the fluidized powder can escape from the cover.

– Close the filling cover of the powder hopper again.



4. Set coating parameters:

1. Turn on the gun control unit with the **ON** key
2. Press the corresponding application key.

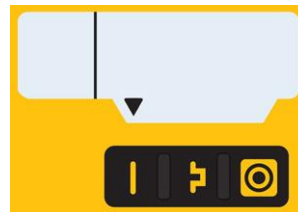
The arrow above the desired button lights up.



The pre-defined application modes have preset values for high voltage and spray current:

Application mode		Preset μA	Preset kV
	flat parts	100	100
	complicated parts	22	100
	overcoat	10	100

3. The air values for total air, powder output and electrode rinsing air can be individually defined and are saved in the programs.

Starting the user-defined operating mode (Program mode)

1. Turn on the gun control unit with the **ON** key



2. Press the  program key
3. Select desired program (01-20)

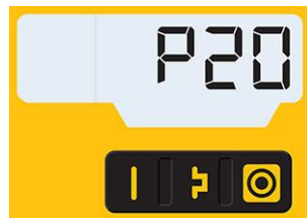







Program 20 active

4. Change coating parameters as required



Programs 01-20 are preset at the factory but can be modified at any time, after which they are automatically stored.

Description	Presetting
 Powder output	60 %
 Total air	4.0 Nm ³ /h
 High voltage	80 kV
 Spray current	20 μA
 Electrode rinsing air	0.1 Nm ³ /h
 Fluidizing air	1.0 Nm ³ /h (for OptiFlex-F) 0.1 Nm ³ /h (for OptiFlex-B and S)

Setting powder output and powder cloud

The powder output depends on the selected powder output (in %), and the powder cloud on the selected total air volume.

▶ **As a factory default value, a powder rate of 50% and a total air volume of 4 Nm³/h are recommended.**

- If values are entered that the gun control unit cannot implement, then the operator is informed of this by a blinking in the relevant display and a temporary error message!

Setting the electrode rinsing air

1. Press the  key.
The second display level will be shown.



Adjust the correct electrode rinsing air according to the applied nozzles (deflector plate, flat jet nozzle)

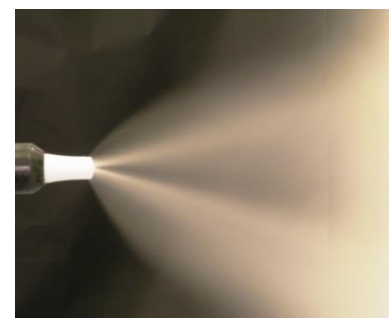
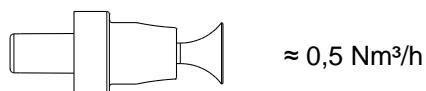
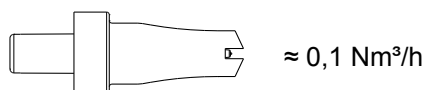

too much electrode rinsing air

3. If in this display level is no operation for 3 seconds, the first display level is switched over independently.

Setting the fluidization

The powder fluidization depends on the powder type, the air humidity and the ambient temperature. Fluidizing and vibration start by switching on the control unit.

1. Press the  key
The second display level will be shown



2. Adjust the fluidizing air with the keys **T5/T6**
 - If in this display level is no operation for 3 seconds, the device switches back to the first display level
3. Check fluidization of the powder in the powder container
 - The powder should only be touched gently, but should be "cooked" regularly and is also to be stirred using a rod

CAUTION

Large dust formation possible!

If the fluidization has been incorrectly adjusted, then the coating powder can create a dust cloud capable of causing respiratory problems.

- ▶ Adjust the fluidization correctly.

4. Point the gun into the booth (not at the object to be coated), press the gun trigger and visually check the powder output
5. Check whether everything is functioning correctly
6. Coating
7. Adjust the coating parameters as necessary
8. Activate the rinsing function periodically

Rinsing mode

The rinsing mode enables blowing off powder accumulations in the powder hose.

Activating the rinsing function

Manual equipment without optional PowerClean module (system parameter P01=0)

The rinsing mode can only be activated from standby mode (main menu display, no powder conveying).



On OptiFlex 2 F Manual coating equipment, the injector must be disconnected prior to cleaning procedure, on OptiFlex 2 B, the suction unit must be lifted, and on OptiFlex 2 S, the powder container must be empty.

1. Detach the injector



- 2.



or



3. **START =**



1 x

= Automatic Procedure



2 x

= Manual Procedure



Procedure	Effect
Automatic (automatic)	<ul style="list-style-type: none"> - The rinsing process is started - Injector, powder hose, gun and spray nozzle are purged using compressed air - The PowerClean function enables parallel cleaning of other components, such as the fluid intake unit, powder container, etc. - The rinsing mode is exited if the automatic rinsing sequence has finished.
Manual (manual)	The operator controls the number and length of the PowerClean impulse by pressing the gun trigger a second time

4. **STOP =**

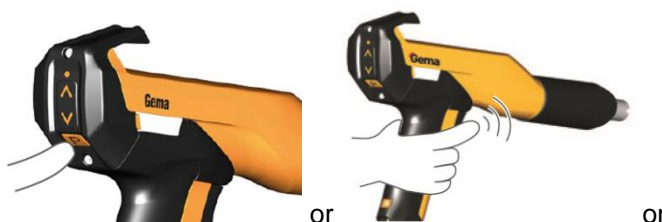

the cleaning mode is terminated automatically.

After completion of the PowerClean procedure, the controller switches back to coating mode.

Manual equipment with optional PowerClean module (system parameter P01= 1 or P01=2)

The rinsing mode can only be activated from standby mode (main menu display, no powder conveying).



2. **START =**

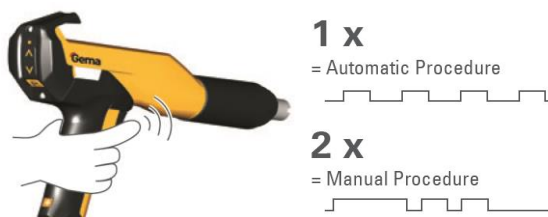

Procedure	Effect
Automatic (automatic)	<ul style="list-style-type: none"> – The rinsing process is started – Injector, powder hose, gun and spray nozzle are purged using compressed air – The PowerClean function enables parallel cleaning of other components, such as the fluid intake unit, powder container, etc. – The rinsing mode is exited if the automatic rinsing sequence has finished.
Manual (manual)	The operator controls the number and length of the PowerClean impulse by pressing the gun trigger a second time

3. STOP =

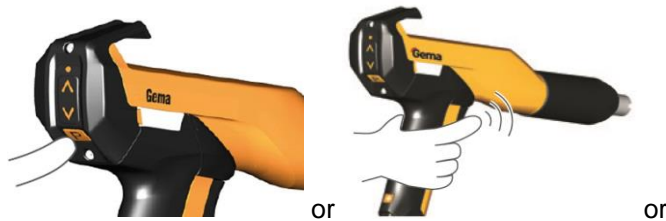

the cleaning mode is terminated automatically.







After completion of the PowerClean procedure, the controller switches back to coating mode.

Color change

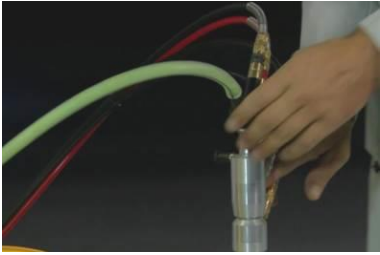
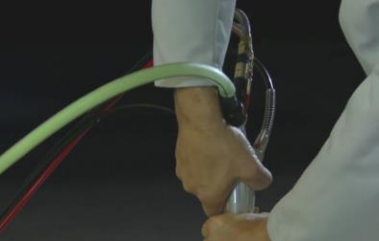
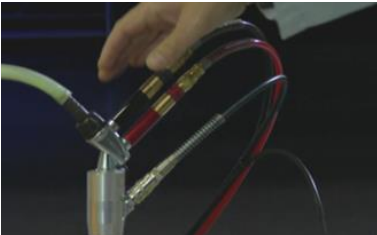
General information

When a color change takes place, the individual components of the manual coating equipment must be cleaned carefully. All powder particles of the former color must be removed during this process!

The following describes an 'extreme' color change (light to dark).

1. 
2. 
3. 
4. 
5. 
6. 
7. 
8. 
9. 
10. Remove and clean the nozzle, purge gun using air



15. Disconnect the fluidizing air supply
16. Remove cover, purge with compressed air and clean with a clean, dry brush and cloth
17. Clean the suction tube
18. Empty remaining powder into a container
19. Vacuum up the hopper and in particular the bottom
20. Clean container with a cloth
21. Reassemble the powder hopper
22. Fill with new powder





Decommissioning / Storage

Decommissioning

1. End the coating procedure
2. Switch off the control unit



The adjustments for high voltage, powder output volume and electrode rinsing air remain stored.

If in disuse for several days

1. Separate from power mains
2. Clean guns, injectors and powder hoses (see therefore the corresponding user manuals)
3. Turn off the compressed air main supply

Maintenance / Repairs

General information

The product was designed for a maintenance-free operation.

ATTENTION

Any unauthorized modifications and alterations to the product are not permitted for safety reasons and exclude the manufacturer's liability for any resulting damage!



Regular and conscientious cleaning and maintenance increase the service life of the product and ensure consistent high coating quality!

- The parts to be replaced during maintenance work are available as spare parts. These parts can be found in the appropriate spare parts list!

Interval

Daily maintenance

1. Clean the injector (see therefore the user manual of the OptiFlow injector)
2. Clean the powder gun (For more on this, please also review the user manual for the OptiSelect GM03 manual powder gun)
3. Clean the powder hose; Please also review the section "Color change"

Weekly maintenance

1. Clean powder container, injector, rinsing module** and powder gun.
2. Check the control unit grounding connections to the coating booth, the suspension devices of the work pieces, or the conveyor chain

If in disuse for several days

1. Separate from power mains
2. Clean the coating equipment
3. Turn off the compressed air main supply

Powder hose rinsing

If longer downtimes take place, the powder hose has to be cleaned.

Procedure:

1. Disconnect the powder hose from the hose connection on the injector
2. Point the gun into the booth
3. Blow through the hose manually with a compressed air gun
4. Connect the powder hose again to the hose connection on the injector

Gun maintenance

The gun is designed to require only a minimum amount of maintenance.

1. Clean the gun with dry cloth, see chapter "Maintenance"
2. Check connection points to powder house.
3. Replace the powder hoses, if necessary.

Cleaning

CAUTION

Large dust formation possible!

If no dust mask or one of an insufficient filter class is worn when cleaning the product, then the dust that is stirred up from the coating powder can cause respiratory problems.

- ▶ The ventilation system must be turned on for all cleaning work.
- ▶ A dust mask corresponding to filter class FFP2 or N95 at minimum must be worn during any cleaning work.

Gun cleaning

ATTENTION

Impermissible solvents

The following solvents may not be used to clean the gun:

- ▶ Ethylene chloride, acetone, ethyl acetate, methyl ethyl ketone, methylene chloride, premium gasoline, turpentine, tetrachloromethane, toluene, trichloroethylene, xylene!



Only cleaning agents with a flash point of a least 5 Kelvin above the ambient temperature, or cleaning places with technical ventilation are allowed!



Before cleaning the powder gun, switch off the control unit. The compressed air used for cleaning must be free of oil and water!

Daily:

1. Blow off the outside of the gun and wipe, clean etc.

Weekly:

2. Remove powder hose
3. Remove the spray nozzle from the gun and clean it with compressed air
4. Blow through the gun with compressed air, beginning from the connection in flow direction
5. Blow through the gun with compressed air, beginning from the connection in flow direction
6. Clean the integrated gun tube with the brush supplied if necessary
7. Blow through the gun with compressed air again
8. Clean the powder hose
9. Reassemble the gun and connect it

Cleaning the powder container

ATTENTION

Damage to the fluidizing plate

- ▶ Never clean the powder container with solvents or water!

1. Disconnect the fluidizing air supply
2. Remove the injector
3. Remove PowerClean module**
4. Remove the cover, blow out with compressed air and clean with a clean dry brush and cloth
5. Clean the injector and suction intake pipe (Please review injector manual for more on this)
6. Clean rinsing module**
7. Empty remaining powder into a container
8. Vacuum up the hopper and in particular the bottom
9. Clean container with a cloth
10. Reassemble the powder hopper



Do not refill the powder container until just before the next use!

Fault clearance



Prior to any troubleshooting measures, always check whether the equipment parameter (P00) as configured in the control unit is correct

- ▶ See operating instructions for the OptiStar CG13 manual gun control unit, Chapter "Initial Start-up – Setting Equipment Type"!

Incident	Causes	Corrective action
H11 (Help code on control unit)	Gun not connected	Connect the gun
	Gun plug or gun cable defective	Contact local Gema representative
	Remote control on powder gun defective	Contact local Gema representative
Control unit displays remain dark, although the control unit is switched on	Control unit is not connected to the mains	Connect the equipment with the mains cable
	Power pack fuse defective	Replace the fuse
	Power pack defective	Contact local Gema representative
Gun LED remains dark, although the gun is triggered	High voltage adjustment is set too low	Increase high voltage
	Gun plug or gun cable defective	Contact local Gema representative
	LED on gun defective	Contact local Gema representative
Powder does not adhere to object, although the gun is triggered and sprays powder	High voltage and current deactivated	Check the high voltage and current setting
	High voltage cascade defective	Contact local Gema representative
	The objects are not properly grounded	Check the grounding
The gun does not spray powder, although the control unit is switched on and the gun trigger is pressed	Compressed air not present	Connect the equipment to the compressed air
	Injector or nozzle on the injector, powder hose or powder gun clogged	Clean the corresponding part
	Insert sleeve in the injector is clogged	Clean/replace
	Fluidization not running	see below

Incident	Causes	Corrective action
	Pressure valve in the control unit defective	Replace
	Solenoid valve in the control unit defective	Replace
	No conveying air: – Throttle motor defective – Solenoid valve defective	Contact local Gema representative
	Front plate defective	Contact local Gema representative
Gun achieving only poor spray profile	Total air incorrectly configured	Increase the powder quantity and/or total air volume on the control unit
	Bend or damage to air lines to injector	Check air lines to injector
	Insert sleeve in the injector worn or not inserted	Replace or insert it
	Fluidization not running	see below
No electrode rinsing air	Rinsing air throttle motor defective	Contact local Gema representative
The powder is not fluidized	Compressed air not present	Connect the equipment to the compressed air
	Fluidizing air is set too low on the control unit	Set the fluidizing air correctly
	Throttle motor defective	Contact local Gema representative
Powder flows out of the powder hopper	Airmover pressure incorrectly set	Adjust

OptiStar CG13



For further information, see the corresponding operating manual, which can be found on the accompanying CD.

Design and function

Overall view



fig. 5:

- | | | | |
|---|---|---|----------------------------|
| 1 | Front plate with control and display elements | 3 | Back panel with interfaces |
| 2 | Enclosure | | |

Operating elements

Displays



The desired and actual values are distributed across several levels. The "sel" key is used to switch between the levels. If no controls are used within 6 s, the device automatically returns to level 1.

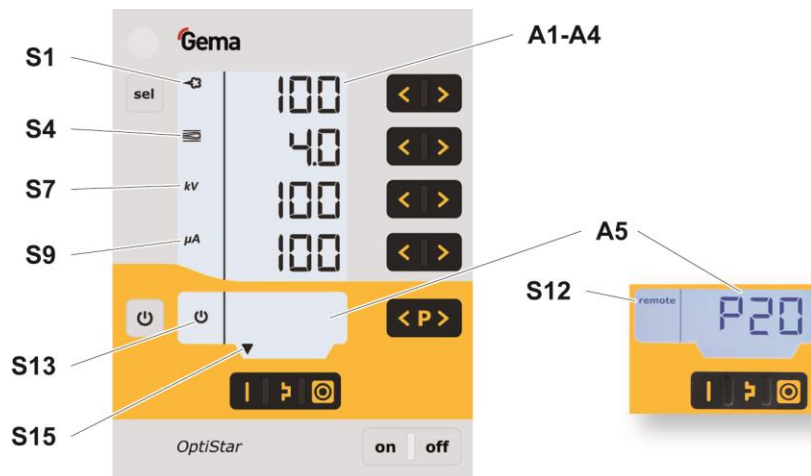

fig. 6: Displays, Level 1

Designation	Function
A1-A4	Display of actual values, desired values and system parameters – Flashes if the possible range is exceeded.
A5	Display of program numbers, error diagnosis codes and status information
S1	Powder output (display in %)
S4	Total air volume (display in Nm ³ /h)
S7	High voltage (display in kV)
S9	Spraying current (display in µA)
S12 remote	Remote operation mode is used as keyboard lock, reduced operation is possible
S13	Activation of vibration/fluidization
S15	Display of predefined operating modes or display of rinsing mode during cleaning

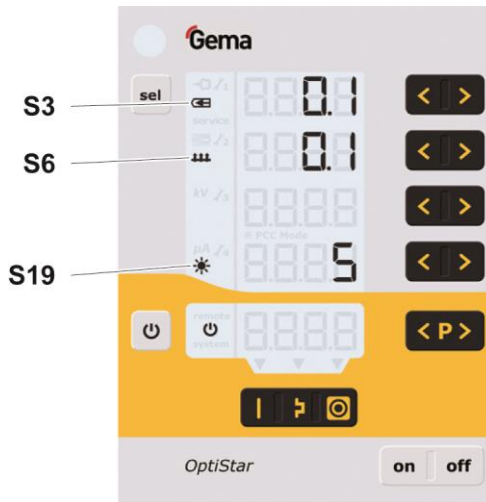

fig. 7: Displays and LEDs, Level 2

Designation	Function
S3	Electrode rinsing air (display in Nm ³ /h)
S6	Fluidizing (display in Nm ³ /h)
S19	Display illumination (0-8)

Input keys and switches

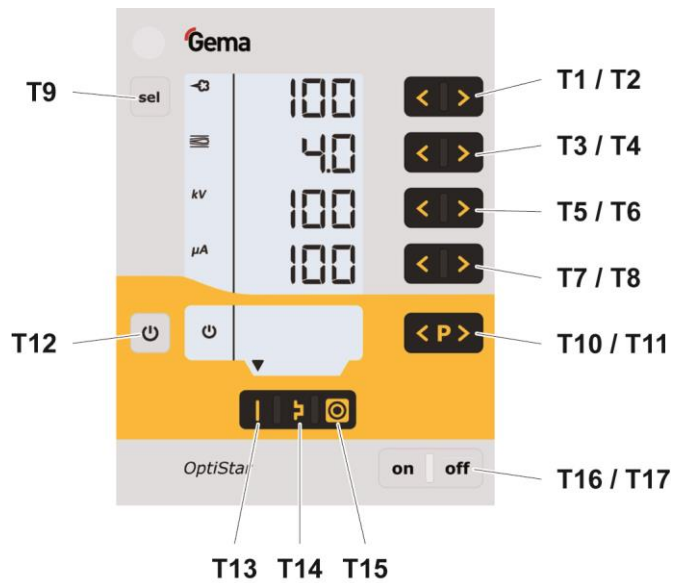

fig. 8: Input keys and switches

Designation	Function
T1-T8	Input keys for desired values and system parameters
T9 (Select)	Switch between display levels
T10-T11	<ul style="list-style-type: none"> - Program change - Terminating the rinsing mode (PowerClean) with optional PowerClean module

Designation	Function
T12	<ul style="list-style-type: none"> – Switching on and off the fluidization (OptiFlex F) – Switch on/off for vibration and fluidization (OptiFlex B) – Switching on and off the stirrer (OptiFlex S) – Switchover to system parameter mode (press for at least 5 secs.)
T13	Preset mode for flat parts (fixed values)
T14	Preset mode for complex parts with depressions (fixed values)
T15	<ul style="list-style-type: none"> – Preset mode for overcoating parts already coated (fixed values) – Switching on the rinsing mode (PowerClean) with optional PowerClean module (Press for at least 5 secs.)
T16/T17	Power switch On/Off

Fault clearance

Error diagnosis of the software

General information

The correct function of the Gun control unit is constantly monitored. If the equipment software determines a fault, an error message is indicated with a help code. Following is monitored:

- High voltage technology
- Pneumatic system
- Power supply

Help codes

The error diagnosis codes (help codes) are shown in red on the **A5** display.



The help codes are stored in an error list in the order of their appearance. Each error in the list must be individually acknowledged with the keys **T10** or **T11**.

The errors are displayed in the order of their appearance. The **T10** and **T11** keys cannot be used for other functions, as long as an error code is still shown.

Here is a list of all possible help codes for this Gun control unit:

Code	Description	Criteria	Remedy
Pneumatics:			
H05	PowerClean valve	<ul style="list-style-type: none"> – PowerClean valve not connected – Valve defective – Connection cable defective – Mainboard defective 	connect or replace Contact a Gema service center
H06	Trigger valve	Solenoid coil current lower than preset limiting value Valve defective, main board or cable defective	Contact a Gema service center
H07	Supplementary air volume too high (setting of supplementary air on the display)	The preset value for supplementary air is too high compared to the conveying air setting	Lower supplementary air value or increase value for conveying air to equalize air volumes to the injector, delete error code
H08	Conveying air volume too high (setting of powder share on the display)	The preset value for conveying air is too high compared to the supplementary air setting	Lower conveying air value or increase value for supplementary air to equalize air volumes to the injector, delete error code
H09	Powder output higher than 100%	The powder output multiplied by the powder hose length factor and daily correction value is greater than 100% Daily correction value too large	Reduce powder output Reduce daily correction value
H10	Conveying air range lower deviation	The theoretical value for conveying air falls below minimum Total air is smaller than minimum	Limit conveying air to its minimum value
High voltage:			
H11	Gun error	No vibrations in the oscillator, cable break, oscillator or gun is defective	Contact a Gema service center
H13	Intermediate circuit voltage too high	Mainboard defective, device is switched off	Contact a Gema service center
H14	Offset spray current measurement	Grounded current measurement	Contact a Gema service center
Power supply:			
H21	Supply undervoltage	Power pack defective or overloaded	Contact a Gema service center
EEPROM (equipment memory):			
H24	EEPROM content invalid	EEPROM error	Contact a Gema service center
H25	Timeout during EEPROM writing	EEPROM error	Contact a Gema service center
H26	Values not correctly stored in EEPROM during switching off	EEPROM error	Contact a Gema service center

Code	Description	Criteria	Remedy
H27	EEPROM verification erroneous	EEPROM error	Contact a Gema service center
Throttle motors:			
H60	Conveying air reference position not found	Throttle motor or needle jammed, limit switch defective, error in motor throttle	Contact a Gema service center
H61	Supplementary air reference position not found	Throttle motor or needle jammed, limit switch defective, error in motor throttle	Contact a Gema service center
H62	Electrode rinsing air reference position not found	Throttle motor or needle jammed, limit switch defective, error in motor throttle	Contact a Gema service center
H64	Conveying air throttle does not move	Short circuit in limit switch, motor throttle defective	Contact a Gema service center
H65	Supplementary air throttle does not move	Short circuit in limit switch, motor throttle defective	Contact a Gema service center
H66	Electrode rinsing air throttle does not move	Short circuit in limit switch, motor throttle defective	Contact a Gema service center
H68	Conveying air position lost	Lost steps, limit switch defective, throttle motor defective	Contact a Gema service center
H69	Supplementary air position lost	Lost steps, limit switch defective, throttle motor defective	Contact a Gema service center
H70	Electrode rinsing air position lost	Lost steps, limit switch defective, throttle motor defective	Contact a Gema service center
H71	Fluidizing air position lost	Lost steps, limit switch defective, throttle motor defective	Contact a Gema service center
Communication mainboard-gun:			
H90	Communication error Mainboard	Mainboard defective	Contact a Gema service center
H91	Communication error mainboard-gun	Gun not connected Gun, gun cable or Mainboard defective	connect Replace or contact Gema Service
H92	Communication error Mainboard	Mainboard defective	Contact a Gema service center

Help codes list

The last appeared four errors are stored in a list by the software. If an error appears, which is already in the list, he will not be listed again.

Appearance of errors

It is possible that an error is only displayed for a short time, but after the acknowledgement it will disappear. In this case, it's recommended to switch off the control unit and switch it on again (reset by restarting).

OptiSelect GM03



For further information, see the corresponding operating manual, which can be found on the accompanying CD.

Structure

Overall view

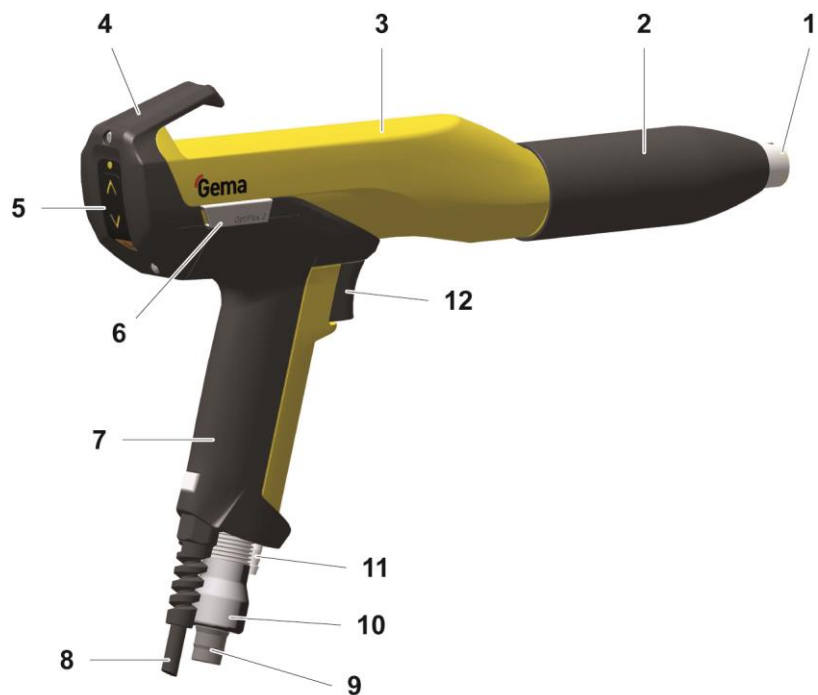

fig. 9:

- | | | | |
|---|-------------------------------------|----|--------------------------------------|
| 1 | Spray nozzle system | 8 | Gun cable |
| 2 | Threaded sleeve | 9 | Powder hose connection |
| 3 | Shaft | 10 | Powder hose quick release connection |
| 4 | Cover with remote control and hooks | 11 | Electrode rinsing air connection |
| 5 | Remote control | 12 | Trigger |
| 6 | SuperCorona connection | | |
| 7 | Gun handle | | |

Operating elements

LED and remote control buttons



fig. 10

Designation	Function
L1	Display High voltage (intensity)
T1	Powder output + key
T2	Powder output – key
T3	Activate/stop rinsing process key

Scope of delivery

- Manual gun with gun cable (6 m), negative polarity
- Powder hose (6 m, ID 10 mm)
- Rinsing air hose (6 m)
- Flat jet nozzle NF20, complete (incl. electrode holder)
- Flat jet nozzle NF21
- Cable tie with Velcro closure
- Gun cleaning brush
- Spare parts kit
- Operating manual

Available accessories**



- Rinsing module (with OptiStar CG09/CG13 manual powder gun control unit only)
- SuperCorona ring
- Flat jet nozzle (for specific applications)
- Round jet nozzles
- Gun extension 150 and 300 mm
- Gun cable extensions
- Application cup 150 and 500 ml
- Multi-spray adapter

- Various adapters for connection to earlier generations of control units
- Gloves, anti-static

**for more information, see spare parts list

Technical Data

Electrical data

OptiSelect GM03	
Nominal input voltage	eff. 10 V
Frequency	18 kHz (average)
Nominal output voltage	100 kV
Polarity	negative (optional positive)
Max. output current	100 µA
High voltage display	with LED
Ignition protection	Ex 2 mJ T6
Temperature range	0 °C - +40 °C (+32 °F - +104 °F)
Max. surface temperature	85 °C (+185 °F)
Protection type	IP64
Approvals	  0102 II 2D PTB 11 ATEX 5006

Dimensions

OptiSelect GM03	
Weight	520 g

Processible powders

OptiSelect GM03	
Plastic powder	yes
Metallic powder	yes
Enamel powder	no

Fault clearance



Additional error descriptions are to be found also in the control unit operating instructions!

Incident	Causes	Corrective action
H11 (Help code on control unit)	Gun not connected	Connect the gun
	Gun plug or gun cable defective	Contact local Gema representative
	Remote control on powder gun defective	Contact local Gema representative
Gun LED remains dark, although the gun is triggered	High voltage adjustment is set too low	Increase high voltage
	Gun plug or gun cable defective	Contact local Gema representative
	LED on gun defective	Contact local Gema representative
Powder does not adhere to object, although the gun is triggered and sprays powder	High voltage and current deactivated	Check the high voltage and current setting
	High voltage cascade defective	Contact local Gema representative
	The objects are not properly grounded	Check the grounding
The gun does not spray powder, although the control unit is switched on and the gun trigger is pressed	Compressed air not present	Connect the equipment to the compressed air
	Injector or nozzle on the injector, powder hose or powder gun clogged	Clean the corresponding part
	Insert sleeve in the injector is clogged	Clean/replace
	Pressure valve in the control unit defective	Replace
	Solenoid valve in the control unit defective	Replace
	No conveying air: <ul style="list-style-type: none"> – Throttle motor defective – Solenoid valve defective 	Contact local Gema representative
	Front plate defective	Contact local Gema representative

Incident	Causes	Corrective action
Gun achieving only poor spray profile	Total air incorrectly configured	Increase the powder quantity and/or total air volume on the control unit
	Bend or damage to air lines to injector	Check air lines to injector
	Insert sleeve in the injector worn or not inserted	Replace or insert it
	Fluidization not running	see above

OptiFlow IG06



For further information, see the corresponding operating manual, which can be found on the accompanying CD.

Structure

Overall view

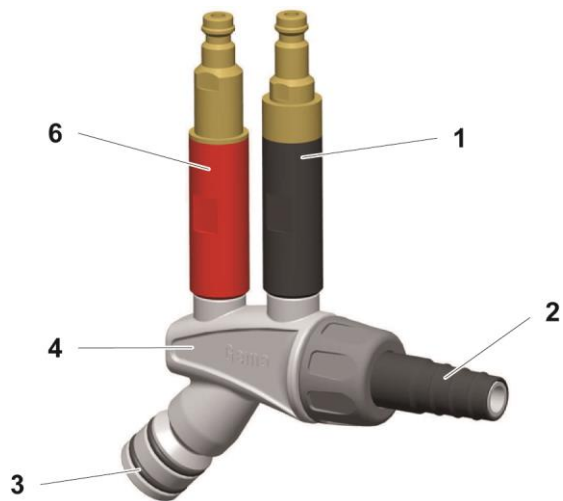

fig. 11

- | | |
|--|--|
| 1. Check valve unit
(supplementary air) | 4. Injector housing |
| 2. Powder hose quick release
connection | 6. Check valve unit
(conveying air) |
| 3. Powder hopper connection | |

Powder volume setting for OptiFlow Injector

In order to set the ideal powder volume on the OptiStar gun control unit, it is recommended to select the firmness of the powder cloud or the total air first. As guide values for different powder hoses, the following can be assumed:

- Powder hose 74 type, Ø 10 mm, **3-5 m³/h**
- Powder hose 66 type, Ø 11 mm, **4-5 m³/h**

According to the prevailing conditions (powder, powder hose layout, the parts to be coated) a low to lowest total air can also be set with the standard hose 74 type, Ø 10 mm.

If a very large powder output is required, it is recommended to select a larger powder hose internal diameter (Ø 12 mm).



It should be noted, that if irregular or pumping conveying occurs, as a rule, the total air is set too low!

Maintenance / Repairs

Cleaning

ATTENTION

Any unauthorized modifications and alterations to the product are not permitted for safety reasons and exclude the manufacturer's liability for any resulting damage!



Regular and conscientious cleaning and maintenance increase the service life of the product and ensure consistent high coating quality!

- The parts to be replaced during maintenance work are available as spare parts. These parts can be found in the appropriate spare parts list!

Cleaning the injector

1. Remove the injector
2. Remove the powder hose from the hose connection (2)
3. Clean the hose connection (2) with compressed air which is free of oil and water, and check for wear
4. Clean the injector body (4) with compressed air which is free of oil and water.
 - Any contamination can be seen through the opening of the hopper fitting (3)
5. If the injector is severely fouled, it must be dismantled

ATTENTION

Injector parts may be damaged during the cleaning process.

- ▶ Remove the check valve units (1 and 6) with the correct sized spanner.
- ▶ Clean the component parts with compressed air and, if necessary, dissolve sintered deposits with nitro-thinner.
- ▶ Do not use acetone, do not scrape!

6. Reinsert the injector and fix it

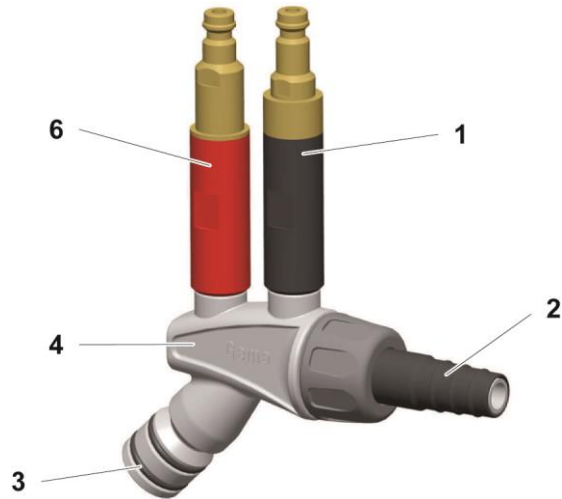

fig. 12

- | | |
|---|-------------------------------------|
| 1. Check valve unit (supplementary air) | 4. Injector housing |
| 2. Powder hose quick release connection | 6. Check valve unit (conveying air) |
| 3. Powder hopper connection | |

Cleaning the check valve units

ATTENTION

Parts of the check valve unit may be damaged during the dismantling process.

- ▶ Blow off the filter elements from the inside to the outside!
- ▶ Do not immerse the filter elements in fluidities or solvents

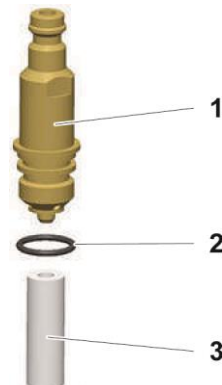
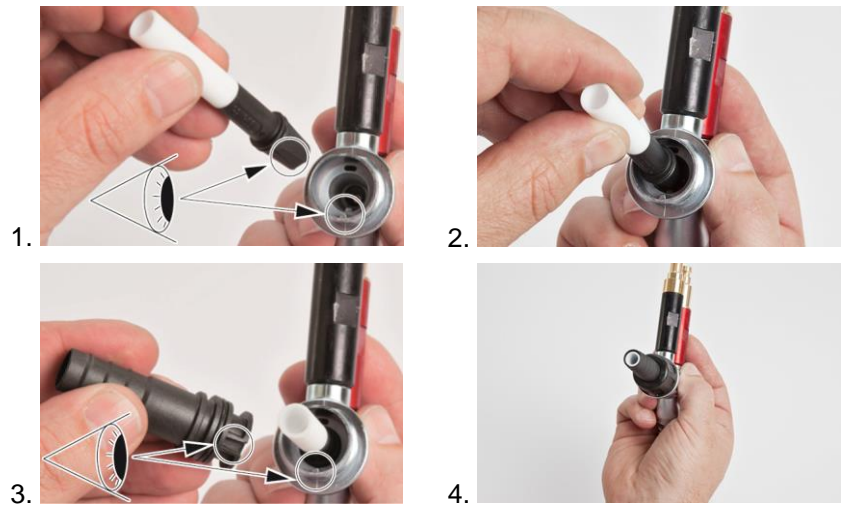

fig. 13

- | | |
|-------------------|------------------|
| 1 Connection/plug | 3 Filter element |
| 2 O-ring | |

Replacing the insert sleeve



Fault clearance

Faults

The following lists possible faults during operation and their clearance.

Fault	Cause	Corrective action
The gun does not spray powder although the control unit is switched on	Injector nozzle, check valve unit, powder hose or powder gun are clogged	Clean the corresponding parts and if necessary, replace them
Gun achieving only poor spray profile	Conveying vacuum too low	Increase the powder quantity and/or total air volume on the control unit
	Insert sleeve worn, not or incorrect inserted	Replace or install the insert sleeve. Observe the indexing cam!
Insert sleeve is worn after a short operating duration		Clean the nozzle, if damaged, replace it

Spare parts list

Ordering spare parts

When ordering spare parts for powder coating equipment, please indicate the following specifications:

- Type and serial number of your powder coating equipment
- Order number, quantity and description of each spare part

Example:

- **Type** OptiGun GA03 automatic powder gun
Serial number 1234 5678
- **Order no.** 203 386, 1 piece, Clamp – Ø 18/15 mm

When ordering cable or hose material, the required length must also be given. The spare part numbers of this bulk stock is always marked with an *.

Wearing parts are always marked with a #.

All dimensions of plastic hoses are specified with the external and internal diameter:

Example:

Ø 8/6 mm, 8 mm outside diameter (o/d) / 6 mm inside diameter (i/d)

ATTENTION

Use of non-original Gema spare parts

When using the spare parts from other manufacturers the explosion protection is no longer guaranteed. If any damage is caused by this use all guarantee claims become invalid!

- ▶ Only original Gema spare parts should be used!
-

OptiFlex 2 F – Spare parts list

1	OptiStar CG13 gun control unit – complete (see corresponding operating manual)	1009 971
2	GM03 manual powder gun – complete (see corresponding user manual)	1008 070
3	OptiFlow IG06 injector – complete (see corresponding user manual)	1007 780
4	Pneumatic connection for conveying air – complete (incl. Pos. 4.1, 4.2, 4.3)	
4.1	Quick release connection – NW5, Ø 8 mm, red	261 645
4.2	Nut with kink protection – M12x1 mm, Ø 8 mm	201 316
4.3	Plastic tube – Ø 8/6 mm, red	103 500*
5	Pneumatic connection for supplementary air – complete (incl. Pos. 5.1, 5.2 and 5.3)	
5.1	Quick release connection – NW5, Ø 8 mm, black	261 637
5.2	Nut with kink protection – M12x1 mm, Ø 8 mm	201 316
5.3	Plastic tube – Ø 8/6 mm, black	1008 038*
6	PowerClean module** – complete (See operating instructions OptiSelect GM03 manual powder gun)	1007 362
7	Pneumatic connection for PowerClean air** – complete (incl. Pos. 7.1 and 7.2)	
7.1	Quick release connection** – NW5, Ø 8 mm	1008 027
7.2	Hose** – Ø 8/6 mm, black	103 152*
8	Powder hopper – complete (without pos. 3)	1007 130
9	Pneumatic connection for conveying air – complete (incl. Pos. 9.1, 9.2 and 9.3)	
9.1	Quick release connection – NW5, Ø 6 mm	200 840
9.2	Nut with kink protection – M10x1 mm, Ø 6 mm	201 308
9.3	Plastic tube – Ø 6/4 mm, black	1001 973
10	Pneumatic group – complete (see corresponding spare parts list)	
11	Quick release connection – NW7,8-Ø 10- Ø 26 mm	239 267
12	Airmover – complete	1002 043
13	Rubber buffer – Ø 35x40 mm, M8 mm	211 664
14	Powder hose – Ø 15/10 mm, 6 m	1001 673*#
15	Short description	1007 143
16	Operating manual	1007 142

* Please indicate length

Wearing part

OptiFlex 2 F – Spare parts

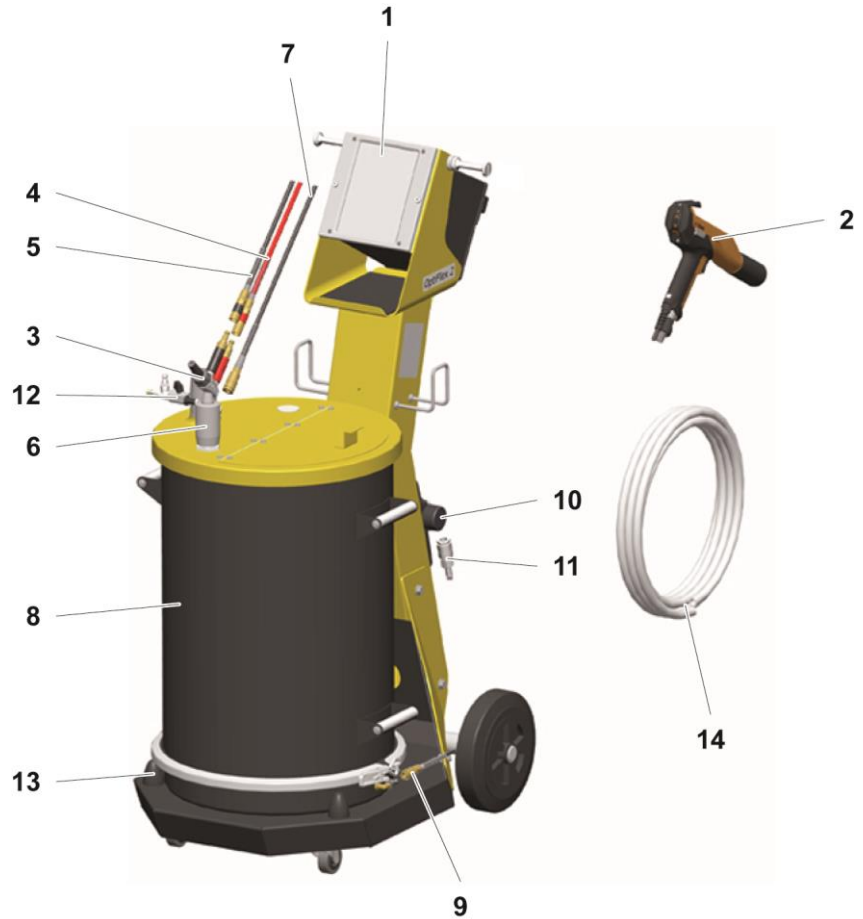

fig. 14

Pneumatic group

	Pneumatic group – complete	1008 235
1	Filter cartridge – 20 µm	1008 239#
2	Plug – Ø 8 mm	238 023

Wearing part

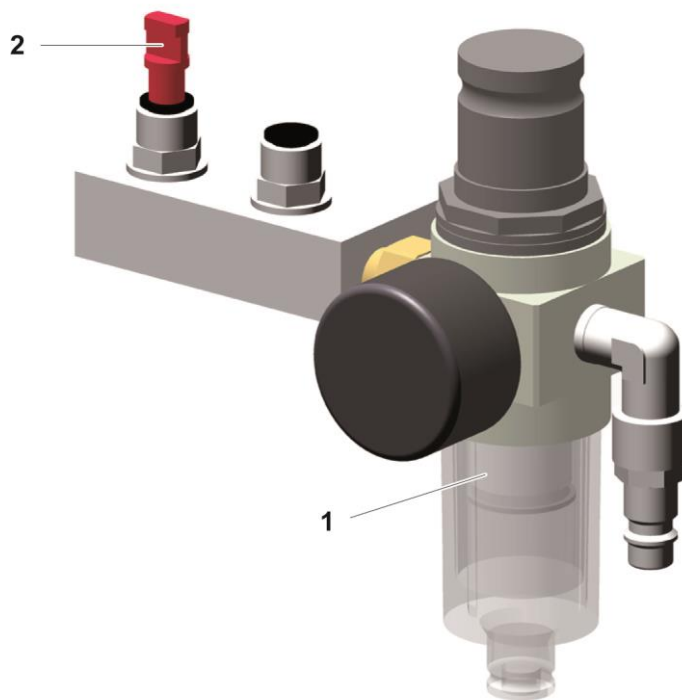

fig. 15: Pneumatic group

PowerClean module set**

	PowerClean module set – rinsing air hose length 2 m (pos. 1, 2, 3, 4 – 8)	1010 519
	PowerClean module set – rinsing air hose length 12 m (pos. 1, 2, 3.1 – 8)	1010 520
1	PowerClean module** – complete (See operating instructions OptiSelect GM03 manual powder gun)	1009 528
2	Solenoid valve – complete	1009 928
3	PowerClean module cable – complete, length 1 m	1009 879
3.1	PowerClean module cable – complete, length 15 m	1009 880
4	Quick release connection – NW5-Ø 8 mm	1008 027
5	Plastic tube – Ø 8/6 mm, black	103 152*
6	Gasket (not shown)	#
7	O ring – Ø 16x2 mm, NBR70, anti-static (2x) (not shown)	#
8	Cable tie (not shown)	

* Please indicate length

Wearing part



fig. 16: PowerClean module set**

OptiStar CG13 Gun control unit

	OptiStar CG13 Gun control unit – complete	1009 971
1	Front plate – complete, see corresponding spare parts list	
2	Enclosure	
3	Backplate – complete, see corresponding spare parts list	
4	Cover	1008 301

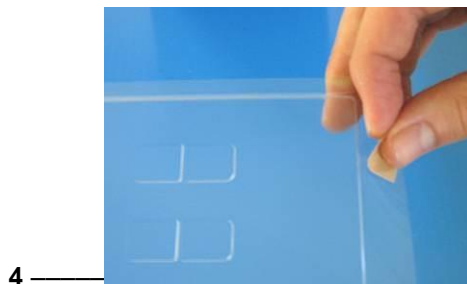

fig. 17

Front plate and power pack

	Front plate – complete (pos. 1-12)	1009 860
	Front plate with foil keyboard (pos. 5-8)	1009 859
1	OptiStar Mainboard – complete	1009 844
2	Spacer sleeve – Ø 3.1/6x15 mm	
3	PCB "Powerboard" – complete	1009 865
4	Spacer sleeve – Ø 3.2/6x7 mm	
5	Front frame – complete (incl. pos. 5.1)	1007 048
5.1	Screw	1007 019
6	Screw – M4x20 mm	1003 000
7	Front plate gasket	1007 042
8	Membrane keypad	
9	Spacer sleeve – Ø 3.6/7x5 mm	
10	Display	1007 044
11	Washer – Ø 3.2/7x0.5 mm	
12	Locknut – M3	
13	Power pack – 24 VDC	1009 849

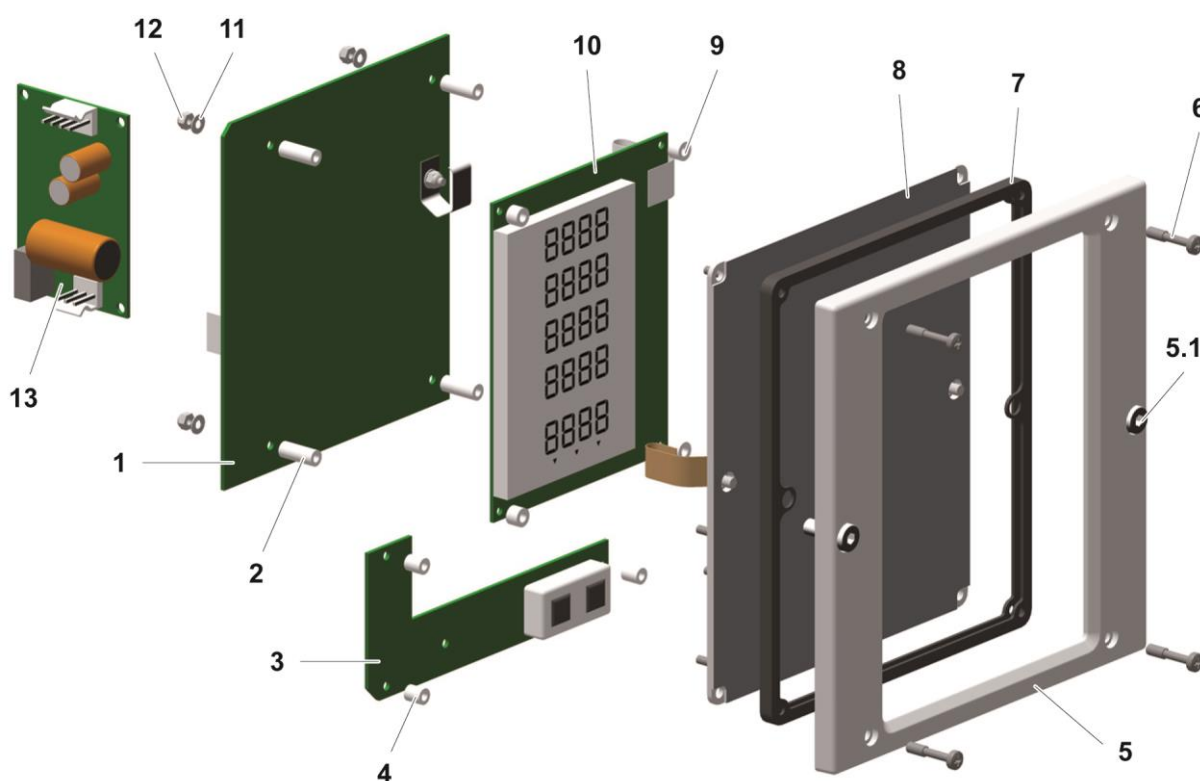

fig. 18

Inside back plate

1	Back plate gasket	1007 033
2	Motor throttle – complete	1008 012
3	T-piece – 1/4"- Ø 8- Ø 8 mm	1008 040
4	Solenoid valve – Ø 8-Ø 8 mm, 24 VDC	1003 914
5	Motor throttle – complete	1000 064
6	Plastic tube – Ø 8/6 mm	103 152*
7	Fluidizing pad – 1/8"	237 264
8	Screw – M4x16 mm	1013 925

* Please indicate length

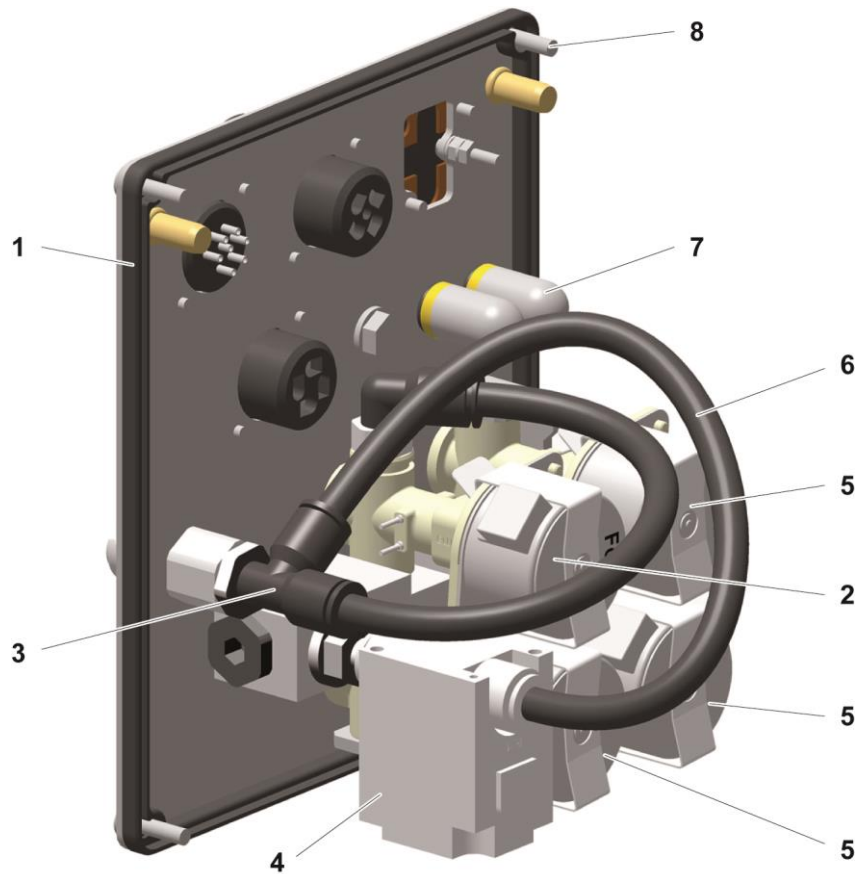

fig. 19:

Connecting material

1	Quick release connection – NW5, Ø 6 mm	200 840
1.1	Hose – Ø 6/4 mm	100 854*
2	Nut with kink protection – M12x1 mm, Ø 8 mm	201 316
2.1	Spraying air hose – Ø 8/6 mm (black)	103 756*
2.2	Quick release coupling for spraying air hose – NW5-Ø 8 mm	261 637
3	Nut with kink protection – M12x1 mm, Ø 8 mm	201 316
3.1	Conveying air hose – Ø 8/6 mm (red)	103 500*
3.2	Quick release coupling for transport air hose – NW5-Ø 8 mm	261 645
4	Hose – Ø 8/6 mm	103 756*
5	Quick release connection – NW 5-Ø 6 mm	200 840
5.1	Hose – Ø 6/4 mm	100 854*
6	Vibrator cable (constituent part of vibrator)	
8	PowerClean module cable – 1 m (option)	1009 879
	PowerClean module cable – 15 m (option)	1009 880
9	Mains cable – CH	382 493
	Mains cable – Schuko	382 485
	Mains cable – USA	382 507
	Mains cable – GB	382 515
	Mains cable – AUS	382 523
	Mains cable – China	1000 993

* Please indicate length

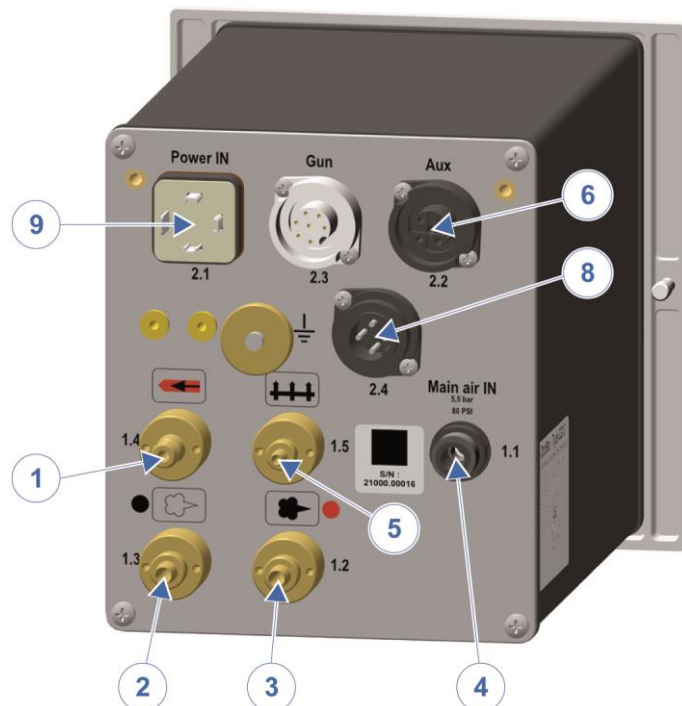

fig. 20

OptiSelect GM03 – Spare parts list



Only parts were included in the spare parts list, which the user can replace himself without problems!

- ▶ If the powder gun cable is defective, it is to be completely sent in for repair!

A	OptiSelect GM03 manual powder gun – complete negative polarity, incl. gun cable – 6 m, rinsing air hose – 6 m, flat jet nozzle, brush and parts kit, without powder hose	1008 070
	OptiSelect GM03 manual powder gun – complete positive polarity, incl. gun cable – 6 m, rinsing air hose – 6 m, flat jet nozzle, brush and parts kit, without powder hose	1008 073
B	Manual powder gun shaft OptiSelect GM03 (incl. cascade) with:	
	Gun cable 2 m, negative polarity (–)	1007 971
	Gun cable 6 m, negative polarity (–)	1007 972
	Gun cable 12 m, negative polarity (–)	1007 973
	Gun cable 2 m, positive polarity (+)	1007 974
	Gun cable 6 m, positive polarity (+)	1007 975
	Gun cable 12 m, positive polarity (+)	1007 968
1	Gun body	1007 220
2	Cascade – complete, negative polarity	1007 231
	Cascade – complete, positive polarity	1007 232
3	Print holder – complete	1007 216
4	End plate with hook	1007 217
5	Grip – complete (incl. pos. 5.1 and 5.2)	1007 961
5.1	Grub screw – M3x8 mm	1008 157
5.2	Grip sealing	1007 633
6	Trigger – complete	1007 213
7	Trigger cover	1007 212
8	Countersunk-head screw – M4x6 mm	1000 845
9	SuperCorona connection	1007 238
10	Gun cable 2 m – complete	1007 963
	Gun cable 6 m – complete	1007 964
	Gun cable 12 m – complete	1007 965
11	Rinsing air connection	1000 804
11.1	Rinsing air hose	100 854*
12	Powder tube – complete	1007 958 #
13	Compression spring	1001 488
14	Clip ring	1007 960
15	Hose connection Ø 11-12 mm – complete (incl. pos 15.1)	1001 340 #
	Hose connection Ø 9-10 mm – complete (incl. pos 15.1)	1002 030 #
15.1	O-ring for pos. 15	1000 822 #
16	Threaded sleeve (see corresponding spare parts list)	

17	Nozzle (see corresponding spare parts list)	
18	Cascade space gasket	1007 635#
	Cleaning brush – Ø 12 mm	389 765
	Parts set (not shown), consisting of:	1008 302
	Flat jet nozzle NF21	1007 935#
	MultiSpray-Adapter NF08	1003 634#
	Cable clamp	303 070
	Hose connector – complete, for hose interior Ø 9-10 mm	1002 030
	Powder hose – Ø 10 mm (not shown)	1001 673*#
	Powder hose – Ø 11 mm (not shown)	105 139*#

* Please indicate length

Wearing part

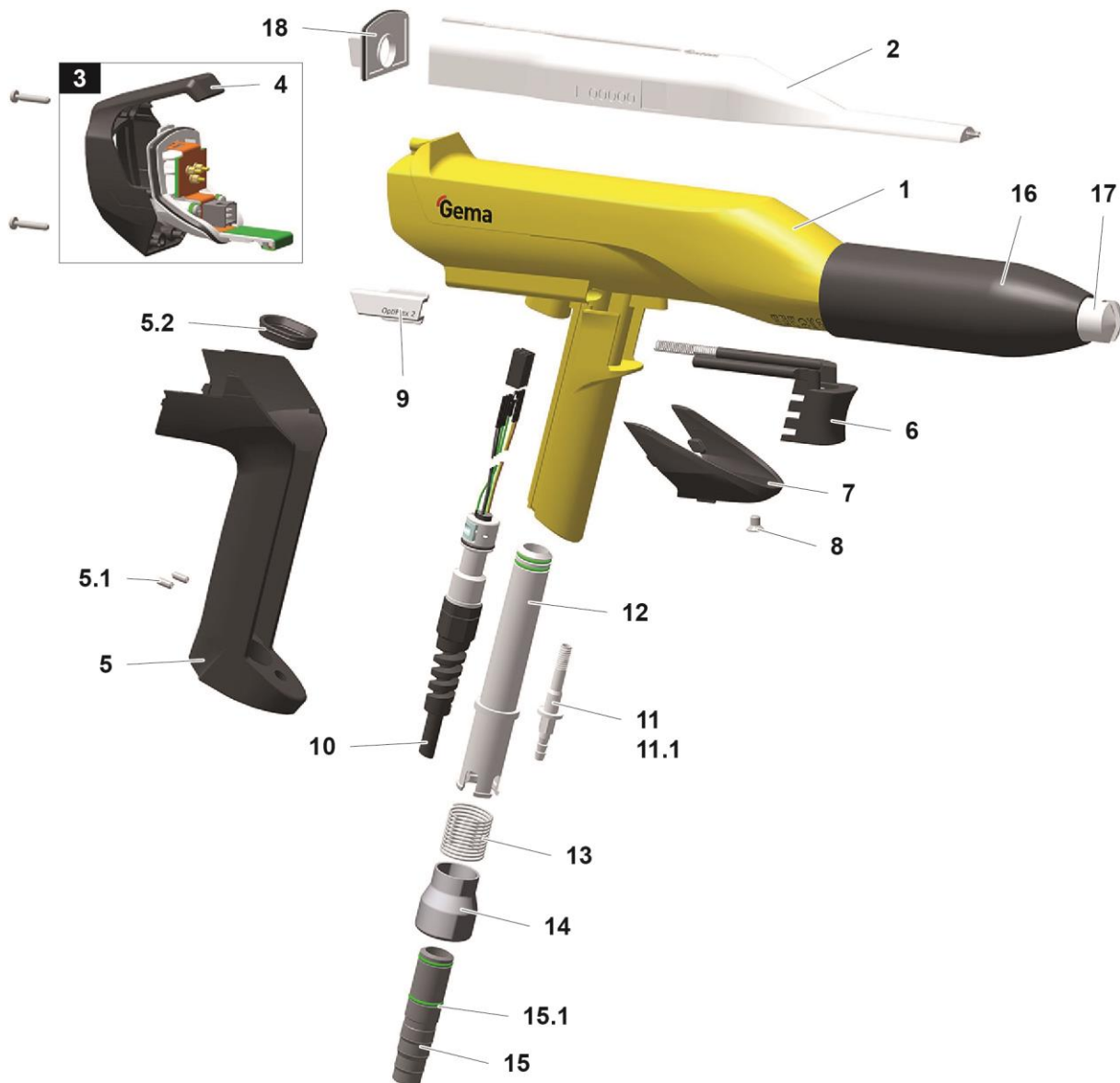

fig. 21: OptiSelect GM03 – spare parts

PowerClean™ module (Option)

	PowerClean module – complete	1009 528
1	Elastomer valve	1000 089#
2	O ring – Ø 16x2 mm, anti-static	1007 794#
3	Fluidizing tube bearing	1007 356
4	Fluidizing tube	1007 355
5	Retaining bracket	1009 524
6	Gasket	1010 101
7	O-ring – Ø 27x2 mm	1009 525

Wearing part

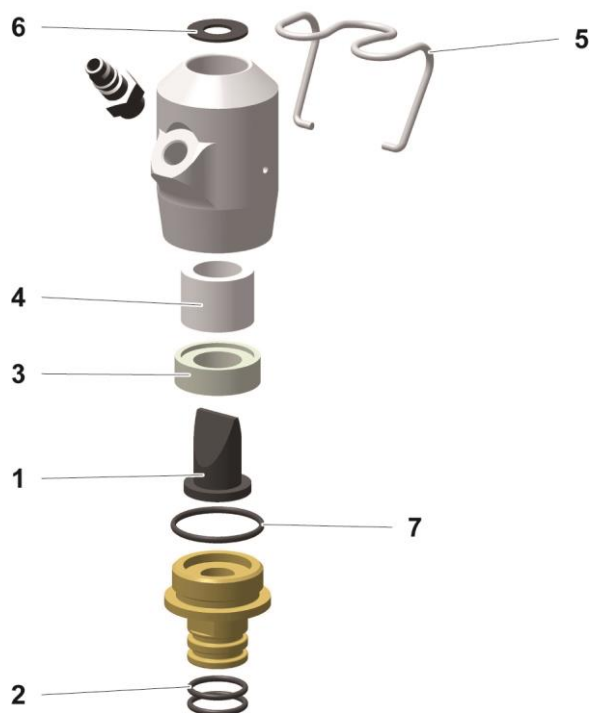

fig. 22

SuperCorona

1 SuperCorona PC05

1008 165#

Wearing part

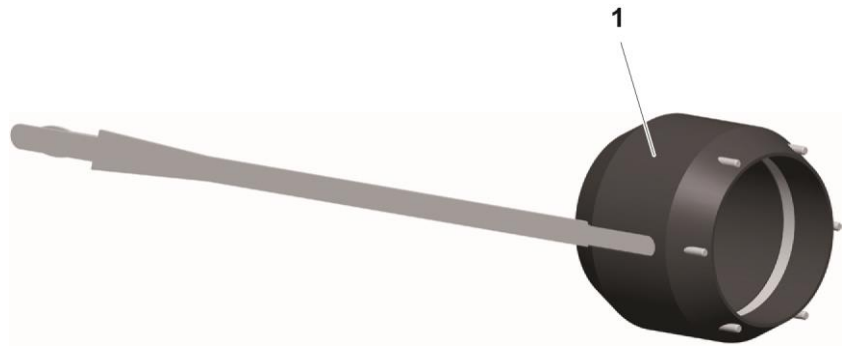









Fig. 23



Accessories

Flat jet nozzles – overview (wearing parts)







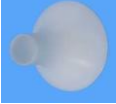

Application	A	B	A + B	Threaded sleeve
Profiles/flat parts (standard nozzle)	 NF20 1010 090		NF20 1010160	
Profiles/flat parts	 NF27 1010 752		NF27 1010 754	 1007 229
Complex profiles and depressions	 NF21 1007 935	 1007 683	NF21 1007 932	
Complex parts (deep recess); target spraying	 NF22 1008 145		NF22 1008 140	
Large surfaces	 NF24* 1008 147		NF24 1008 142	 1008 326

* not suitable for angled nozzles

Round jet nozzle – Overview (wearing parts)

Application	A	B	A + B	Threaded sleeve	Deflectors
Suitable for large surfaces	 NS04 1008 151	 1008 152	NS04 1008 150	 1007 229	
					Ø 16 mm 331 341
					Ø 24 mm 331 333
					Ø 32 mm 331 325
					Ø 50 mm 345 822

Gun extensions

Gun extensions		
	L = 150 mm	L = 300 mm
without nozzle ¹	 1008 616	 1008 617
without nozzle ²	 1007 718	 1007 719
with Flat jet nozzle NF25	 1007 746	 1007 747
with Round jet nozzle NS09	 1007 748	 1007 749

¹ see NF27, NF20, NF21, NF24, NS04

² see NF25, NF26, NS09

ATTENTION

Connecting more than two extensions

It is not permitted to connect more than two extensions together, in order to prevent the gun from being damaged by arising leverage force.

- ▶ The extensions (150 mm/300 mm) may be connected TO ONLY ONE ADDITIONAL extension (150 mm/300 mm), if necessary.

Spray nozzles for extensions – overview (wearing parts)



1007 718



1007 719



Application	A	B	A + B	Threaded sleeve	Deflectors
Profiles/flat parts	 NF25 1007 735	 1007 684	NF25 1007 743	 1007 740	--
Complex profiles and depressions	 NF26 1007 742		NF26 1007 744		--
Suitable for large surfaces	 NS09 1008 257	 1008 258	NS09 1008 259		 Ø 16 mm 331 341 Ø 24 mm 331 333 Ø 32 mm 331 325 Ø 50 mm 345 822

Powder hoses – overview

Powder hose (antistatic)	Application	Diameter	Parts No.*	Material	Type
 <p> Ø 12/ 18 mm Typ 75 Material POE </p> <p> Ø 11/ 16 mm Typ 66 Material POE </p> <p> Ø 10/ 15 mm Typ 74 Material POE </p>	Fast color changes	Ø 11/16 mm	105 139	POE	66
	Fast color changes - low powder flow	Ø 10/15 mm	1001 673	POE	74
	Fast color changes - high powder flow	Ø 12/18 mm	1001 674	POE	75

* Please indicate length

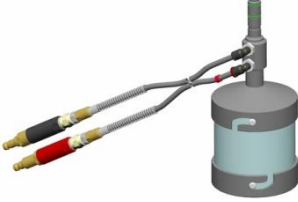
Other accessories

Application cup	<p>150 ml</p>  <p>1004 552</p>	<p>500 ml</p>  <p>1002 069</p>
Gun extension cables	 <p>L=6 m 1002 161</p> <p>L=14 m 1002 162</p>	
Gloves, anti-static (1 pair)	 <p>800 254</p>	

OptiFlow IG06 – spare parts list

	OptiFlow IG06 Powder injector – complete (pos. 1-13)	1007 780
A	Conveying air check valve unit (red marking) – complete (incl. pos. 6, 8, 9 and 12)	1005 589
B	Supplementary air check valve unit (black marking) – complete (incl. pos. 7, 8, 9 and 13)	1005 590
C	Injector body – complete (incl. pos. 1, 2, 10 and 11)	1006 530
1	Injector body (without pos. 2)	1006 484
2	O-ring – Ø 16x2 mm	1007 794#
3	Insert sleeve – PTFE, complete	1006 485#
4	Hose connection – Ø 10-12 mm, complete (incl. pos 4.1)	1006 531
4.1	O-ring – Ø 16x1.5 mm	205 141#
5	Threaded sleeve	1006 483
6	Connector (conveying air) – NW 5.5	1004 366
7	Connector (supplementary air) – NW 5.5	1004 367
8	O-ring – Ø 11x1.5 mm	1000 532#
9	Filter element – Ø 9/4x27 mm	1003 698
10	Nozzle	1006 488
11	Nozzle fixation – complete (incl. pos. 11.1)	1007 792
11.1	O-ring – Ø 8x1 mm	1007 793#
12	Body (red)	1004 369
13	Body (black)	1004 370
16	Conveying air hose – Ø 8/6 mm (red)	103 500*
17	Supplementary air hose – Ø 8/6 mm (black)	1008 038*
18	Quick release coupling for conveying air hose – NW5-Ø 8 mm	261 645
19	Quick release coupling for supplementary air hose – NW5-Ø 8 mm	261 637
20	Kink protection	1008 844
	Powder hose – 66 type, POE, Ø 16/11 mm, with conductive strip (standard)	105 139*#
	Powder hose – 74 type, POE, Ø 15/10 mm, with conductive strip	1001 673*#
	Powder hose – 75 type, POE, Ø 18/12 mm, with conductive strip	1001 674*#

* Please indicate length

Wearing part

OptiFlow IG06 – spare parts

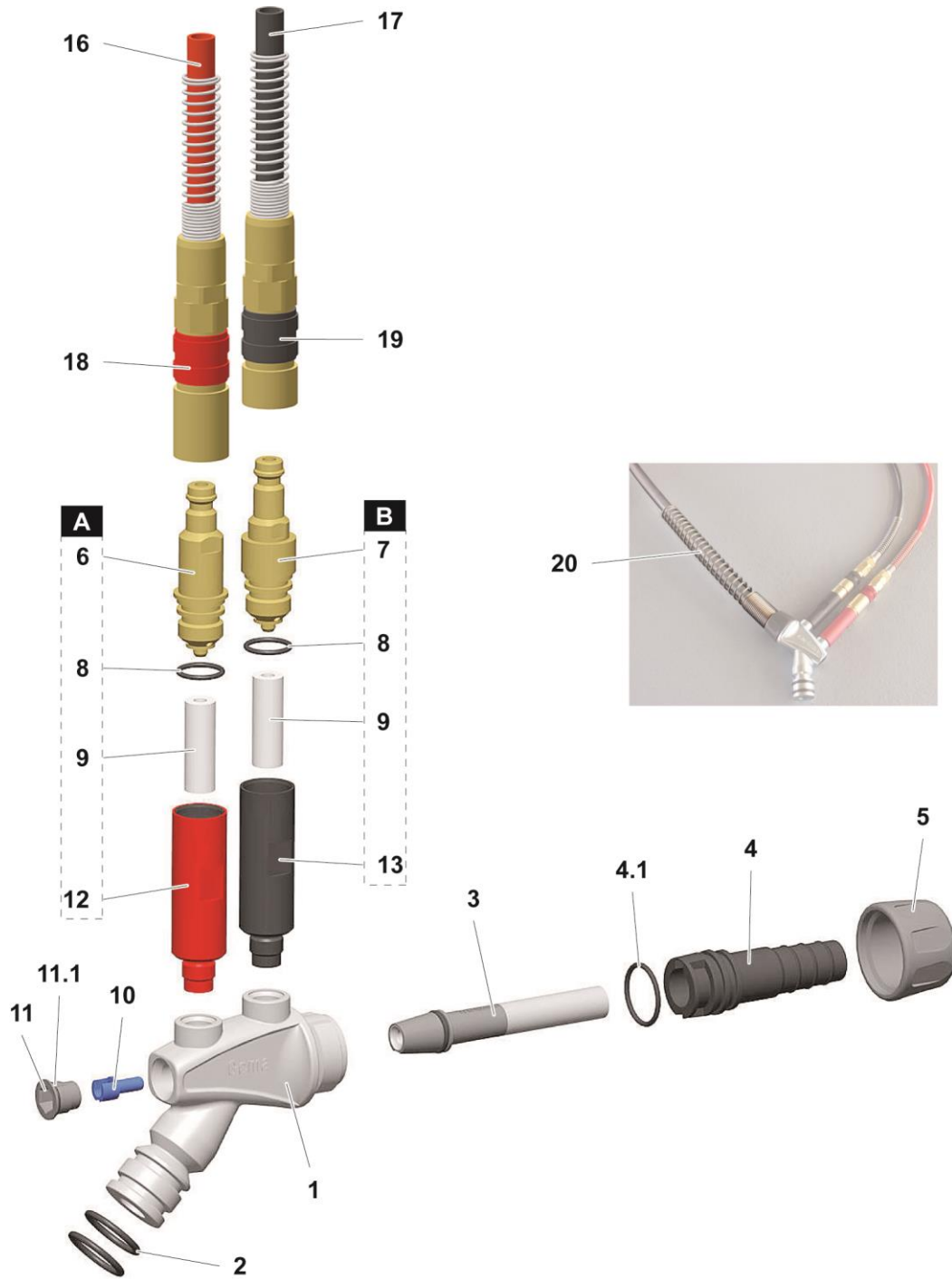

fig. 24

Index

A

About these instructions.....	5
Assembly.....	17

B

Basic safety instructions.....	7
--------------------------------	---

C

Cleaning.....	37, 57
Connectable guns.....	14
Connection.....	17

D

Decommissioning.....	33
Disuse for several days.....	33

E

Electrical data.....	14, 51
----------------------	--------

F

Fault clearance.....	39, 45, 53, 61
Figure references in the text.....	6

M

Maintenance.....	35, 57
------------------	--------

O

Operating elements.....	42
Operation.....	23

P

Pictograms.....	5
Pneumatic data.....	15
Presentation of the contents.....	6
Product specific security regulations.....	8

R

Repairs.....	35, 57
--------------	--------

S

Safety.....	7
Safety symbols.....	5
Spare parts list.....	63
Start-up.....	21
Storage.....	33

T

Technical Data.....	14, 51
---------------------	--------

