

Operating instructions and Spare parts list

Gun control unit OptiStar 4.0 (CG20/-C)

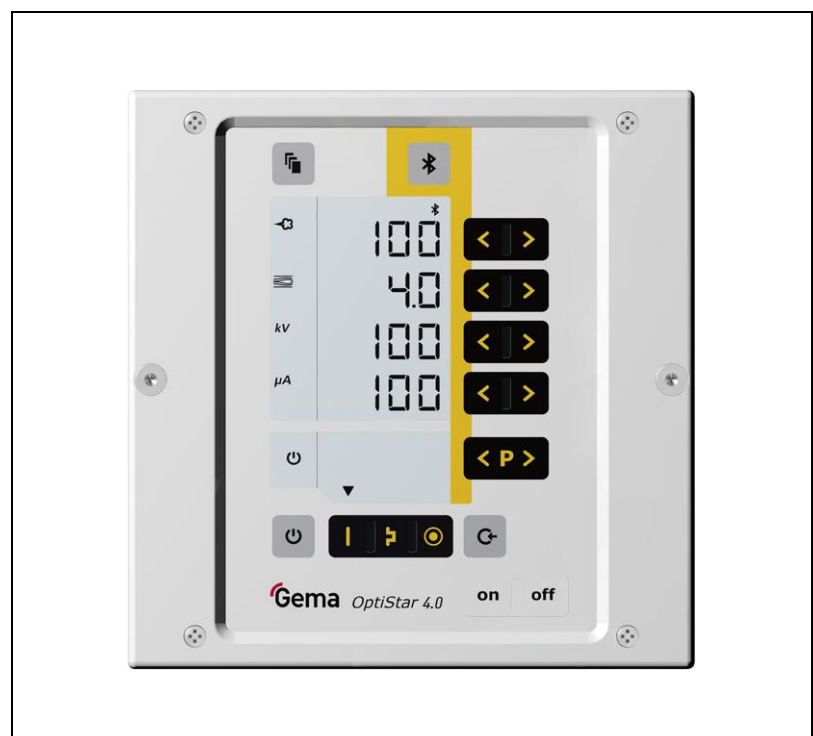

Translation of the original operating instructions

Documentation OptiStar 4.0 (CG20/-C)

© Copyright 2017 Gema Switzerland GmbH

All rights reserved.

This publication is protected by copyright. Unauthorized copying is prohibited by law. No part of this publication may be reproduced, photocopied, translated, stored on a retrieval system or transmitted in any form or by any means for any purpose, neither as a whole nor partially, without the express written consent of Gema Switzerland GmbH.

Gema, EquiFlow, MagicCompact, MagicCylinder, OptiCenter, OptiFlex, OptiGun, OptiSelect, OptiStar, OptiStar All-in-One and PowerBoost are registered trademarks of Gema Switzerland GmbH.

ClassicLine, ClassicStandard, ClassicOpen, DVC (Digital Valve Control), GemaConnect, MagicControl, MagicPlus, MonoCyclone, MRS, MultiColor, MultiStar, OptiAir, OptiControl, OptiColor, OptiFeed, OptiFlow, OptiHopper, OptiMove, OptiSieve, OptiSpeeder, OptiSpray, PCC (Precise Charge Control), RobotGun, SIT (Smart Inline Technology) and SuperCorona are registered trademarks of Gema Switzerland GmbH.

All other product names are trademarks or registered trademarks of their respective holders.

Reference is made in this manual to different trademarks or registered trademarks. Such references do not mean that the manufacturers concerned approve of or are bound in any form by this manual. We have endeavored to retain the preferred spelling of the trademarks, and registered trademarks of the copyright holders.

To the best of our knowledge and belief, the information contained in this publication was correct and valid on the date of publication. Gema Switzerland GmbH makes no representations or warranties with respect to the contents or use of this publication, and reserves the right to revise this publication and make changes to its content without prior notice.

For the latest information about Gema products, visit **www.gemapowdercoating.com**.

For information regarding patents, see **www.gemapowdercoating.com/patents** or **www.gemapowdercoating.us/patents**.

Gema Switzerland GmbH
Mövenstrasse 17
9015 St.Gallen
Switzerland

Phone: +41-71-313 83 00

Email: info@gema.eu.com

Table of contents

About these instructions	7
General information	7
Keeping the Manual	7
Safety symbols (pictograms).....	7
Structure of Safety Notes	8
Software version	8
Presentation of the contents	8
Figure references in the text	8
Safety	11
Basic safety instructions	11
Product specific security regulations	11
Product description	13
Intended use	13
A summary of the directives and standards.....	14
Reasonably foreseeable misuse.....	14
Technical Data	15
Versions	15
Connectable guns	15
Electrical data.....	15
Pneumatic data	16
Dimensions	16
Powder output (reference values).....	16
Air flow rates	17
Environmental conditions.....	18
Sound pressure level	18
Rating plate	18
Design and function	19
Overall view.....	19
Operating elements.....	20
Connections	23
Scope of delivery.....	24
Typical properties – Characteristics of the functions	25
Operating modes	25
Communication with the Gema electrostatic app	27
Rinsing mode	28
Background illumination.....	28
Correction values	28
Assembly / Connection	29
Assembly guide.....	29
Connection instructions.....	30
Start-up	31
Preparation for start-up	31
Basic conditions	31

System parameters	31
Entering the system parameters	31
Pairing of the Bluetooth module with a mobile device	37
CAN bus	37
General	37
Hardware	38
Determining device address (Node-ID) and Baud rate	39
Operation	41
Operation	41
Select predefined operating mode (Preset mode)	41
Starting the individual adjustable programs	42
Setting powder output and powder cloud	42
Setting the electrode rinsing air	44
Remote operation	45
Local operation in remote operating mode	45
Transfer to remote operating mode	45
System release in network operation	45
Correction values	46
Entering the correction values	46
Powder output/powder hose correction	48
Correction factor – diagram	50
Daily correction value C2	50
Rinsing mode	51
Activating the rinsing function	51
Setting the background illumination	52
Checking the software version	52
Checking the trigger time	53
RAM Reset	53
Decommissioning / Storage	55
Shutdown	55
When the product will not be used for several days	55
Storage conditions	55
Hazard notes	55
Type of storage	55
Storage duration	55
Space requirements	55
Physical requirements	56
Maintenance during storage	56
Maintenance schedule	56
Maintenance works	56
Maintenance / Repairs	57
General information	57
Periodic checks	57
Repair work	57
Troubleshooting	59
Error diagnosis of the software	59
General information	59
Help codes	59
Help codes list	62
Appearance of errors	62

Disposal	63
Introduction	63
Requirements on personnel carrying out the work	63
Disposal regulations.....	63
Materials.....	63
Disassembly of component groups.....	63
Spare parts list	65
Ordering spare parts	65
OptiStar CG20(-C) gun control unit.....	66
Front plate and power pack	67
Inside back plate	68
Connecting material	70
Index	73

About these instructions

General information

This operating manual contains all the important information that is needed to operate the OptiStar 4.0 (CG20/-C). It will safely guide you through the start-up process and give you references and tips for the optimal use when working with your powder coating system.

Information about the functional mode of the individual system components should be referenced in the respective enclosed documents.

Keeping the Manual

Please keep this Manual ready for later use or if there should be any queries.

Safety symbols (pictograms)

The following warnings with their meanings can be found in the Gema instructions. The general safety precautions must also be followed as well as the regulations in the relevant instructions.

DANGER

Indicates a hazardous situation, which, if not avoided, will result in death or serious injury.

WARNING

Indicates a hazardous situation, which, if not avoided, could result in death or serious injury.

CAUTION

Indicates a hazardous situation, which, if not avoided, could result in minor or moderate injury.

ATTENTION

Indicates a potentially harmful situation. If not avoided, the equipment or something in its surrounding may be damaged.

ENVIRONMENT

Indicates a potentially harmful situation, which, if not avoided, may have harmful consequences for the environment.

**MANDATORY NOTE**

Information that must be observed.

**NOTICE**

Useful information, tips, etc.

Structure of Safety Notes

Every note consists of 4 elements:

- Signal word
- Nature and source of the danger
- Possible consequences of the danger
- Prevention of the danger

⚠ SIGNAL WORD

Nature and source of the hazard!

Possible consequences of the danger

- ▶ Prevention of the danger

Software version

This document describes the operation of the product OptiStar 4.0 (CG20/-C) with software version starting from 2.00.

See chapter "[Checking the software version](#)" on page 52.

Presentation of the contents**Figure references in the text**

Figure references are used as cross references in the descriptive text.

Example:

"During the typical OptiCenter (7) operation, the powder bag is put in the powder bag cone. The powder is fluidized in the bag with the fluidizing/suction lance and then fed to the OptiSpeeder (9). The fluidized powder is sucked in by the conveyors and fed through the powder hoses to the guns/spray nozzles (8). The powder, which does not adhere to the workpieces, will be absorbed by the exhaust air of the booth (1) and separated from the air in the cyclone separator (2)."

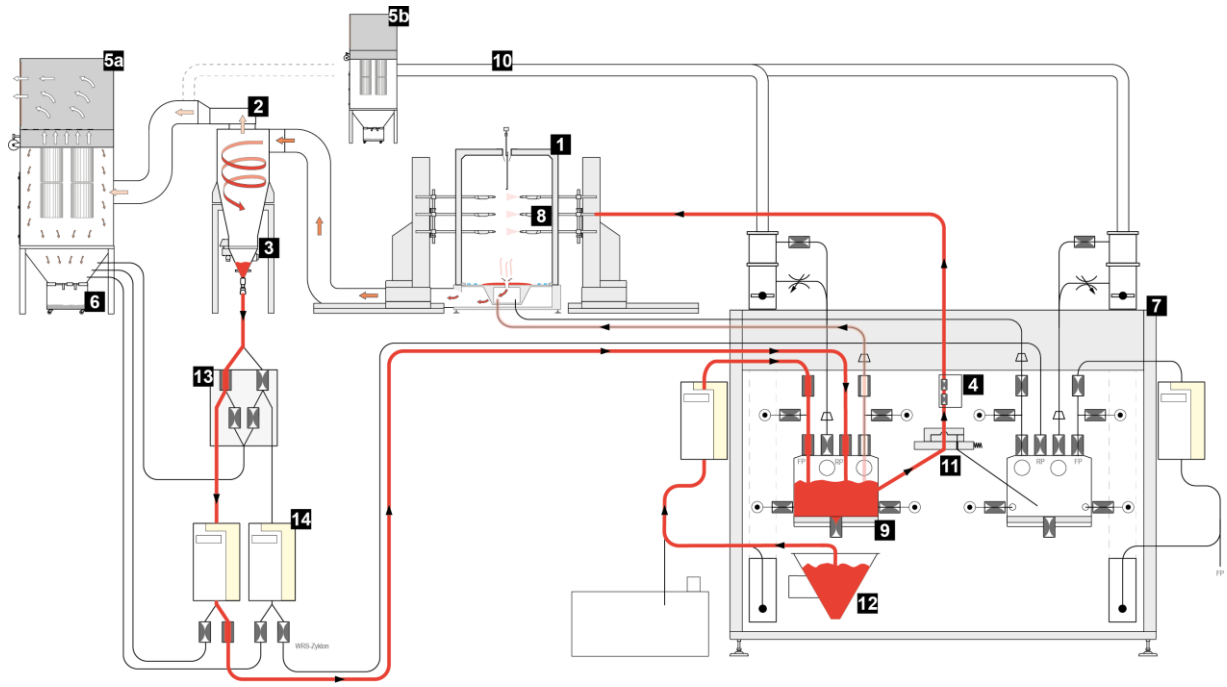

Safety

Basic safety instructions

- This product is built to the latest specification and conforms to the recognized technical safety regulations and is designed for the normal application of powder coating.
- Any other use is not considered as intended use. The manufacturer shall not be liable for damage resulting from such use; the user bears sole responsibility for such actions. If this product is to be used for other purposes or other substances outside of our guidelines then Gema Switzerland GmbH should be consulted.
- Start-up (i.e. the execution of intended operational tasks) is forbidden until it has been established that this product has been set up and wired according to the guidelines for machinery. The standard "EN ISO 12100 Machine safety" must also be observed.
Machine safety
- Unauthorized modifications to the product exempt the manufacturer from any liability from resulting damage.
- The relevant accident prevention regulations, as well as other generally recognized safety regulations, occupational health and structural regulations are to be observed.
- Furthermore, the country-specific safety regulations also must be observed.

Product specific security regulations

- This product is a constituent part of the equipment and is therefore integrated in the system's safety concept.
- If it is to be used in a manner outside the scope of the safety concept, then corresponding measures must be taken.
- The installation work to be done by the customer must be carried out according to local regulations.
- It must be ensured, that all components are earthed according to the local regulations before start-up.



For further security information, see the more detailed Gema safety regulations!

⚠ WARNING**Working without instructions**

Working without instructions or with individual pages from the instructions may result in damage to property and personal injury if relevant safety information is not observed.

- ▶ Before working with the device, organize the required documents and read the section "Safety regulations".
- ▶ Work should only be carried out in accordance with the instructions of the relevant documents.
- ▶ Always work with the complete original document.

Product description

Intended use

This gun control unit is designed exclusively for controlling the Gema powder coating guns (see also in chapter "Technical data").



fig. 1

Observance of the operating, service and maintenance instructions specified by the manufacturer is also part of conformity of use. This product should only be used, maintained and started up by trained personnel, who are informed about and are familiar with the possible hazards involved.

Any other use is considered non-compliant. The manufacturer is not responsible for any incorrect use and the risks associated with such actions are assumed by the user alone!

For a better understanding of the interrelationships in powder coating, it is recommended that the operating instructions for all other components be read as well, so as to be familiar with their functions too!

A summary of the directives and standards

This product is built according to the current state of the art. The product is subject to the European directives and complies with the following standards.

The product is suitable for the intended purpose and can be used in the appropriate areas.



For further information, also refer to the enclosed Declaration of Conformity.

European directives RL

EG-RL 2006/42/EU	Machinery
EG-RL 2014/34/EU	Equipment and Protective Systems in Potentially Explosive Atmospheres (ATEX)
EG-RL 2014/30/EU	Electromagnetic compatibility

EN European standards

EN 50177	Stationary electrostatic application equipment for ignitable liquid coating material - Safety requirements
EN 50050-2	Electrostatic equipment for areas where there is danger of explosion - electrostatic hand held equipment Part 2: Electrostatic hand-held spraying equipment
EN 16985	Spray booths for organic coating material - Safety requirements

Recognized safety-related regulations

764 / DGUV Information 209-052	Electrostatic coating Trade Union information concerning health and safety during work (BGI)
---	---

Reasonably foreseeable misuse

- Operation without the proper training
- Use with insufficient compressed air quality
- Use in connection with unauthorized coating devices or components

Technical Data

Versions

OptiStar	CAN bus
CG20	no
CG20-C	yes

The equipment designation is indicated on the type plate.

Connectable guns

OptiStar	connectable
OptiGun type GA03	yes*
OptiSelect Pro Type GM04	yes
OptiSelect type GM03	yes*
OptiGun type GA02	yes**
TriboJet	yes***

* The PowerBoost functionality is not available.



** with communications adapter – contact Gema

*** The gun type must be configured (refer to chapter "Additional functions"). The Tribo gun is not type approved (ATEX).

WARNING:

The gun control unit may only be used with the specified gun types!

Electrical data

OptiStar 4.0 (CG20/-C)	
Nominal input voltage	100 - 240 VAC
Frequency	50 - 60 Hz
Fluctuations of the power supply	± 10 %
Overvoltage category	OVC II
Connected load	40 VA
Nominal output voltage (to the gun)	12 V
Nominal output current (to the gun)	1.2 A
Protection type	IP54
Max. surface temperature	85 °C (+185 °F)
Approvals	 2813  II 3 (2) D PTB17 ATEX 5002  CL. II, Div 2, Gp F, G T6, Ta 32 to 104 °F (0 to 40 °C)

Pneumatic data

OptiStar	
Compressed air connection	Quick coupling
Input pressure (must be set in the system parameter P2)	5.5 bar 6.0 bar 6.5 bar
Max. input pressure	10 bar / 145 psi
Min. input pressure (while unit in operation)	5.5 bar / 80 psi
Max. water vapor content of the compressed air	1.3 g/m ³ – ISO 8573-1 Class 3-4
Max. oil vapor content of the compressed air (oil/water)	0.1 mg/m ³ – ISO 8573-1 Class 2

Dimensions

OptiStar	
Width	173 mm
Depth	250 mm
Height	177 mm
Weight	approx. 2.6 kg



Powder output (reference values)

General conditions for the OptiFlow Injector

Powder type	Epoxy/polyester
Powder hose Ø (mm)	11
Type of powder hose	POE with guide strips
Input pressure OptiStar (bar)	5.5
Correction value C0	Powder output zeroing adjustment

Guide values for OptiStar with OptiFlow Injector

All values in these tables are guide values for new nozzle inserts. Differing environmental conditions, wear and different powder types can affect the table values.

Hose internal diameter (mm)		Ø 11					
Hose length (m)		6		12		18	
Total air volume  (Nm³/h)		3.5	5.5	3.5	5.5	3.5	5.5
Powder output (g/min)							
Powder output  (%)	20	90	105	65	75	45	60
	40	170	205	135	150	100	120
	60	235	280	185	215	145	170
	80	290	350	235	270	185	220
	100	340	405	280	320	220	260

Air flow rates

The total air consists of conveying air and supplementary air, in relation to the selected powder quantity (in %). As a result the total air volume is maintained constant.

OptiStar 4.0 (CG20/-C)	
Conveying air flow rate	0-5.5 Nm³/h
Supplementary air flow rate	0-5.5 Nm³/h
Electrode rinsing air flow rate	0-5.0 Nm³/h

▶ **The total air consumption for the device is determined based on the configured air values.**

These values apply for a control pressure of 5.5 bar.

▶ **The max. total air consumption during the coating operation is < 5,5 Nm³/h:**

Total air = 5 Nm³/h (conveying air + supplementary air)

Electrode rinsing air = 0.1 Nm³/h (flat jet nozzle).

Environmental conditions

OptiStar 4.0 (CG20/-C)	
Utilization	in the interior
Height	up to 2 000 m
Temperature range	+5 °C - +40 °C (+41 °F - +104 °F)
Max. surface temperature	+85 °C (+185 °F)
Maximum relative humidity	80 % for temperatures to 31 °C, linearly decreasing to 50 % relative humidity at 40 °C
Environment	not for wet environment
Degree of pollution of the intended environment	2 (in accordance with DIN EN 61010-1)

Sound pressure level

OptiStar 4.0 (CG20/-C)	
Normal operation	< 60 dB(A)

The sound pressure level was measured while the unit was in operation; measurements were taken at the most frequent operator positions and at a height of 1.7 m from the ground.

The specified value is applicable only for this product itself and does not take into account external noise sources or cleaning impulses.

The sound pressure level may vary, depending on the product configuration and space constraints.

Rating plate



Fig. 2

Design and function

Overall view



Fig. 3

- | | | | |
|---|---|---|----------------------------|
| 1 | Front plate with control and display elements | 3 | Back panel with interfaces |
| 2 | Enclosure | | |

Operating elements

Displays



The desired and actual values are distributed across several levels.

- The  key is used to switch between the levels.
- If no controls are used within 6 s, the device automatically returns to level 1.

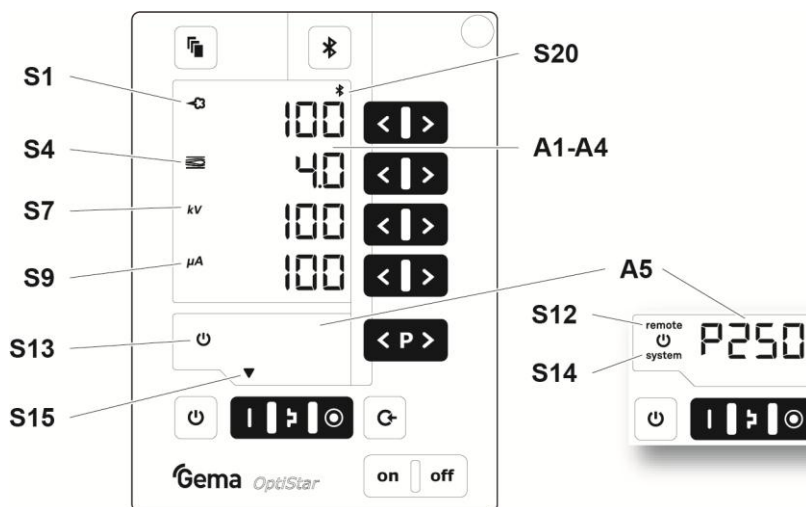

Fig. 4: Displays, Level 1

Designation	Function
A1-A4	Display of actual values, desired values and system parameters <ul style="list-style-type: none"> - Flashes when the possible range is exceeded.
A5	Display of program numbers, error diagnosis codes and status information
S1	Powder output (display in %)
S4	Total air volume (display in Nm ³ /h)
S7	High voltage (display in kV)
S9	Spray current (display in μ A)
S12 remote	Remote operation mode, no local operation possible <ul style="list-style-type: none"> - Remote operation mode is used as keyboard lock, reduced operation is possible
S13	Gun release
S14 system	System release via external release
S15	Display of predefined operating modes or display of cleaning mode during cleaning
S20	<ul style="list-style-type: none"> - Display of readiness for pairing the Bluetooth module with a mobile device (green) - Display of an active connection (blue)

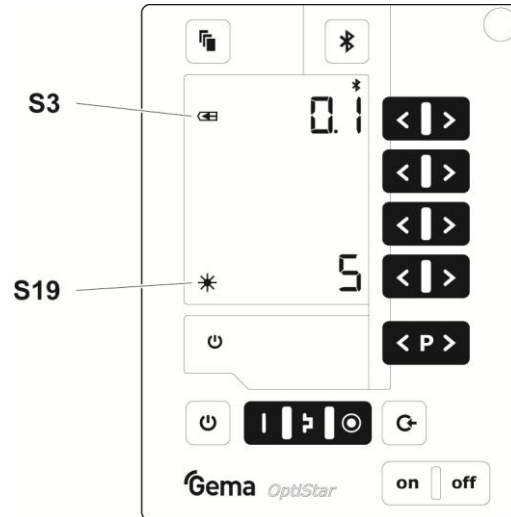

fig. 5: Displays and LEDs, Level 2

Designation	Function
S3	Electrode rinsing air (display in Nm ³ /h)
S19	Display background illumination (0-8)

Input keys and switches

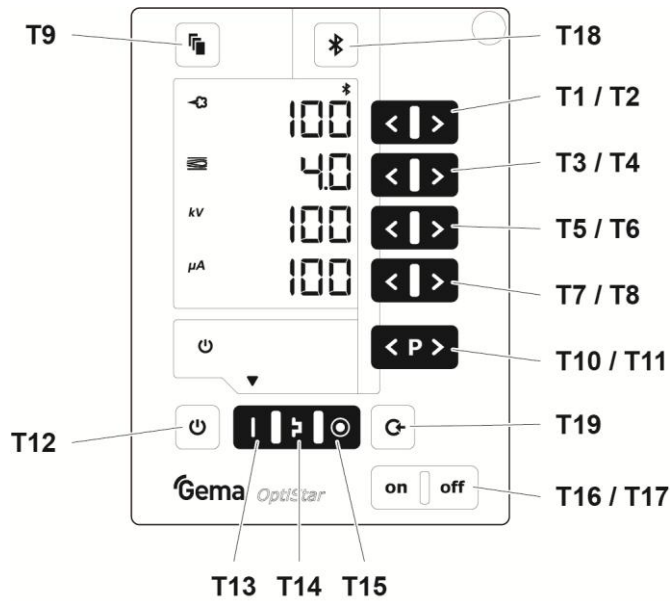

fig. 6: Input keys and switches





Designation	Function
T1-T8	Input keys for desired values and system parameters
T9	Switch between display levels
T10-T11	Program change
T12	<ul style="list-style-type: none"> – Gun release – Switchover to system parameter mode (Press for at least 5 secs.)
T13	Preset mode for flat parts (fixed values)
T14	Preset mode for complex parts with depressions (fixed values)
T15	Preset mode for overcoating parts already coated (fixed values)
T16/T17	Power switch On/Off
T18	<ul style="list-style-type: none"> – Activation of the pairing readiness from the Bluetooth module to the mobile device (press for at least 2 seconds) – Display of the ID number (press for a short time)
T19	Activation of the hose rinsing function

Connections

Compressed air hoses / cables



Fig. 7: Connections

Connection	Description
1.1 Main air IN	Compressed air connection
2.1 Power IN	Mains cable connection
2.2 Gun	Gun cable connection
2.3 Aux	CAN bus connection (IN)
2.4 Aux	CAN bus connection (OUT)
1.2 	Conveying air connection
1.3 	Supplementary air connection
1.4 	Electrode rinsing air connection
	Grounding connection

Pin assignment

Power IN



2.1

Power IN connection

- 1 Neutral conductor (power supply)
- 2 Phase (100-240 VAC)
- 3 External release (100-240 VAC)
- PE PE grounding

Gun

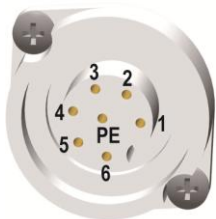

2.2

Gun connection

- 1 Ground
- 2 Remote control 1 (GM03)
- 3 Ground
- 4 Trigger
- 5 Remote control 2 (GM03)
- 6 Oscillator
- 7 Grounding PE

Aux



2.3

CAN IN plug with 4 pins (2.3 Aux)

- 1 Ground
- 2 24 VDC
- 3 CAN high
- 4 CAN low
- Enclosure – shield

Aux



2.4

CAN OUT socket with 4 pins (2.4 Aux)

- 1 Ground
- 2 24 VDC
- 3 CAN high
- 4 CAN low
- Enclosure – shield

Scope of delivery

- Power cable (country-specific)
- Quick-start guide and operating manual

Typical properties – Characteristics of the functions

Operating modes

The gun control unit has two operating modes.

Predefined operating mode (Preset mode)

The gun control unit has three preset application modes:

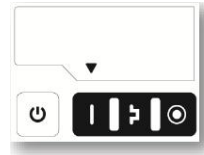

Fig. 8



Application mode for flat parts

This application mode is suitable for the coating of simple, flat workpieces without larger cavities.



Application mode for complicated parts

This application mode is suitable for the coating of three-dimensional workpieces with complex shapes (e.g. profiles).



Application mode for recoating parts already coated

This application mode is suitable for the overcoating of workpieces which are already coated.

In this operating modes, current (μA) and high voltage (kV) are preset, while powder and air volumes can be set and stored for each application mode.

Adjustable operating mode (Program mode)

In this operating mode, 250 individually definable programs (P001-P250) are available. These programs are automatically saved and can be recalled again as the application requires.



Fig. 9

The values for current, high voltage, powder output, total air and electrode rinsing air can be set as needed for a given application.



The settings defined in the 250 programs and 3 application modes are automatically stored, without confirmation!

Precise Control of spraying Current (PCC Mode)

For coating components with both complex and simple geometries, a spraying current of below 10 μA can be selected to prevent unintended overcoating on the simpler surfaces. This is especially important in combination with high loading powders (such as metallic). The controller automatically switches into "PCC mode". This allows for very fast yet highly precise control. The high voltage and spray current values and their symbols are depicted in red:



Fig. 10: PCC mode

Communication with the Gema electrostatic app

The control unit is prepared for communication* with the Gema electrostatic app.



The electrostatic app is optimized for mobile devices with a screen diagonal up to 15 cm (6").

The app enables customers to improve their productivity by providing the following areas:



Application

All important application parameters are clearly displayed on the mobile device and can be adapted immediately.



Line management

The coating productivity data can be retrieved at any time. Statistics and cost estimates of the order are generated automatically. Maintenance can be scheduled.



Setup

This configures the OptiStar control unit, and the OptiStar can be controlled individually or as a participant in a group.

System information and diagnostic data can easily be retrieved and sent as e-mail.

The firmware of the control unit can also be updated directly.



Service

Enables direct access to the operating instructions of the system components and to the Gema website.

The secure connection between the control unit and the device can be established very easily with the help of the  key.

The prerequisite for this is that every control unit in the system already has its own Bluetooth ID number. See chapter "[System parameter P11 \(Bluetooth ID no.\)](#)" on page 36.

A description of the app can be found in a separate manual.

* Disabled in network operation

Rinsing mode

The rinsing mode is used to blow powder accumulations out of the powder hose, injector, and gun using compressed air.



The rinsing mode can only be activated from standby mode, namely by pressing the  key on the gun control unit or also by an optional bus connection such as CAN bus.

See chapter "[Rinsing mode](#)" on page 51.

The rinsing mode is signaled by a circling LCD segment on the display:

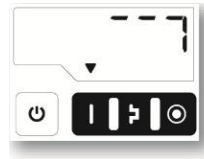

fig. 11: Rinsing mode

The actual rinsing procedure is started and stopped by the superordinated control unit.

Once the rinsing mode is quit, the unit automatically returns to the last program.

Background illumination

Brightness

8 different brightness settings are available for the display. The setting remains in place when the machine is switched on/off.



Fig. 12

Auto Power Save mode

If no powder is being applied, then the background lighting turns off automatically 5 minutes after a button has been pressed last time.

Correction values

The Gun control unit can be adapted with the correction values optimally to local conditions (e.g. the adjustment of different powder outputs in the plant).

See chapter "[Entering the correction values](#)" on page 46.

Assembly / Connection

Assembly guide

The gun control unit is mounted into place using 2xM6 screws on the front side. Please contact Gema for other installation possibilities.



Fig. 13

Connection instructions

The gun control unit is supplied ready for use by the manufacturer. Just a few cables and hoses must be connected. (See chapter "Pin assignment" on page 24.)

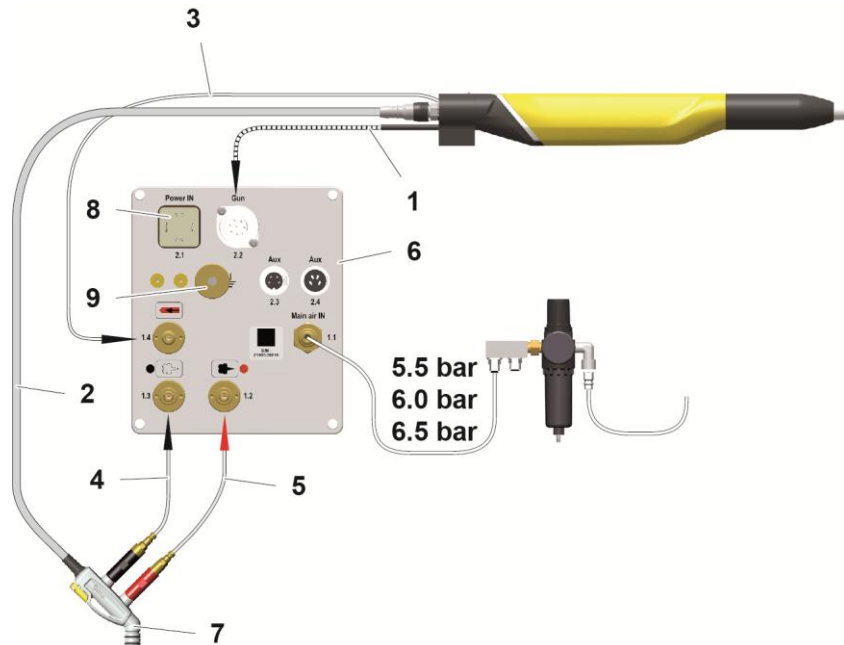

Fig. 14: Connecting guide – overview

- | | | | |
|---|----------------------------|---|-----------------------|
| 1 | Gun cable | 5 | Conveying air hose |
| 2 | Powder hose | 6 | OptiStar Control unit |
| 3 | Electrode rinsing air hose | 7 | Injector |
| 4 | Supplementary air hose | 8 | Power supply |
| | | 9 | Grounding connection |



Connect grounding cable to the booth or the suspension arrangement!

- Check ground connections with Ohm meter and ensure 1 MOhm or less!



The source electrical connections for the Control Units are to be connected in an unclassified location only.



The compressed air must be free of oil and water!



Close the unused connections with the provided dust protection caps!

Start-up

Preparation for start-up



The gun control unit always starts up to the last configured settings.

Basic conditions

When starting up the gun control unit, the following general conditions impacting the coating results must be taken into consideration:

- Gun control unit correctly connected
- Gun correctly connected
- Corresponding power and compressed air supply available
- Powder preparation and powder quality

System parameters

The Gun control unit is configured by using the system parameters. This configuration will be saved in the equipment memory. These values can be adjusted and requested manually or by remote interface (CAN).

Entering the system parameters

1. Turn on the gun control unit with the **ON** key
2. Hold  key down for 5 seconds
 - The display switches to the following level:

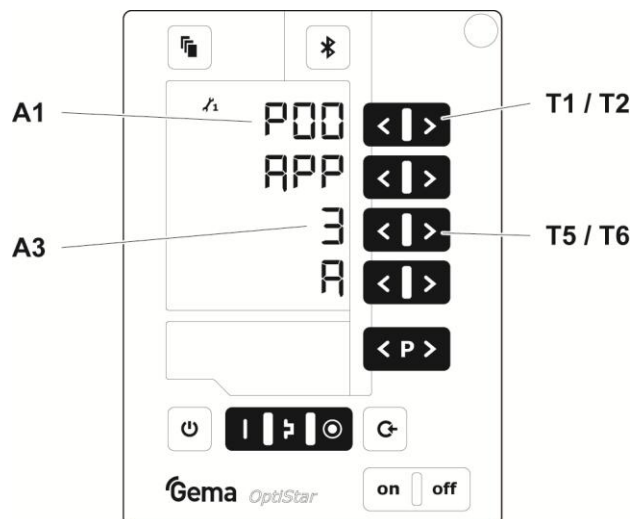

3. The system parameter number is shown in the display **A1** with a **P** placed in front
4. Set the corresponding system parameter value with the **T5** or **T6** key.
 - The value of the adjusted system parameter appears on corresponding display **A3**
5. Scroll to the next or previous system parameter with the **T1** or **T2** key



Selection is cyclical, i.e. after the last system parameter, the first starts again and vice versa.

6. Select parameter values according to the following table

No.	Description	Values	Display
P00¹⁾	Device type	0: Fluidizing device type F (CG21)	F
		1: Box device with vibrator Type B (CG21)	B
		2: Stirrer device Type S (CG21)	S
		3: Automatic device (CG20/CG20-C)	A
		4: Stirrer device with fluidization (CG21)	S Fd
		5: Application pump (CG23-P)	P
		6: Application pump + CAN bus (CG24-CP)	CP
P02	Inlet pressure	0: P in = 5.5 bar 1: P in = 6 bar 2: P in = 6.5 bar	5.5 6.0 6.5
P03	Unit of measurement (air)	0: Nm³/h 1: scfm	nn3 scf

No.	Description	Values	Display
P04	Interface type	0: Deactivated 1: Automatic recognition	OFF Auto
P05	CAN Baud rate	0: 20 kbit/s 1: 50 kbit/s 2: 100 kbit/s 3: 125 kbit/s 4: 250 kbit/s 5: 500 kbit/s 6: 800 kbit/s 7: 1 Mbit/s	2 0 5 0 1 0 0 1 2 5 2 5 0 5 0 0 8 0 0 1 0 0 0
P06	CAN Node ID	1-127	
P07	Air volume setting	0: Standard (PA / GL) 1: Advanced (FL / ZL)	Std Adv
P08	Procedure when changing Local / Remote	0: Gun release is reset 1: Gun release is not changed	RCHG
P09	Reserve		
P10	Log level	0, 1, 2 , 3, 4, 5	LoG
P11	Bluetooth ID no.	0: Bluetooth deactivated 1 - 255	blid
P12	Remote Manual Gun	0: Powder output +/- PowerClean (Activation) 1 : Program change PowerClean (Activation) 2: Powder output +/- PowerBoost (Activation)	PAC PrC PAb

¹⁾ is not overwritten if a memory reset is performed

Default values are marked by **bold** print.

7. Press  key to quit the system parameter mode.
The display switches to the standard level

System parameter P00 (device type)

If the gun control unit is equipped with the CAN bus option, this device type is recognized automatically. The system parameter P00 is set to 3 when device is starting.

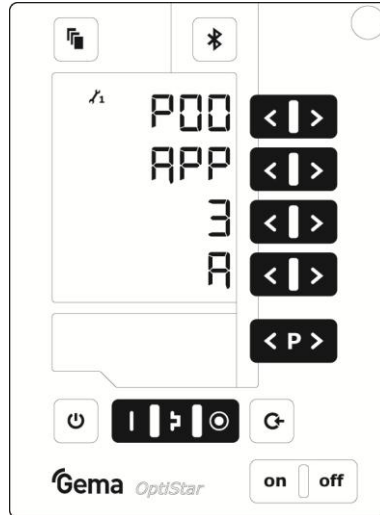

fig. 15: System parameter P00

ATTENTION

A wrong parameterization leads to various malfunctions!

- ▶ The system parameter P00 must be set to 3 (Automatic device)!

System parameter P03 (measuring unit)

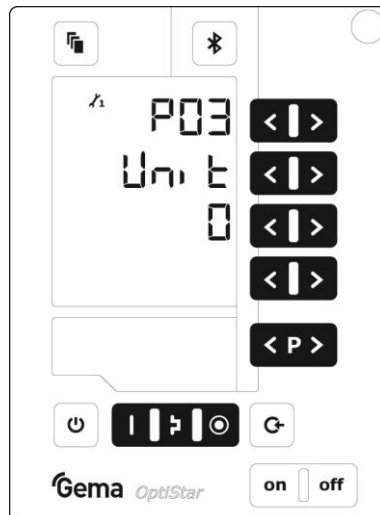

fig. 16: System parameter P03

This parameter is used to determine the measuring unit for all airs (total air and electrode rinsing air). If the parameter is set to **1 (scfm)**, then all air values are shown in this measuring unit. These lines are displayed in **blue**.

System parameter P10

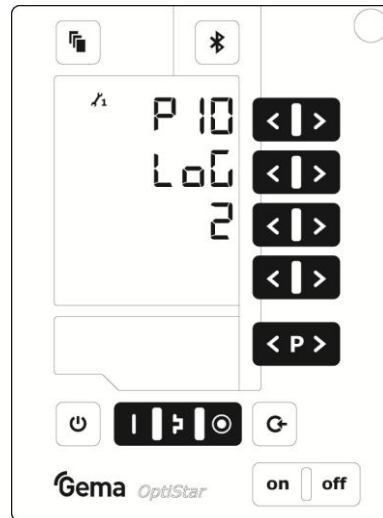

fig. 17: System parameter P10

The device can export log reports of the program run to an SD card for test purposes and for finding defects.

If an SD card is inserted during the switching on procedure, the log messages are also recorded onto the SD card. The data are recorded in the MESSAGES.LOG file in the root directory. Once this file reaches a size of 32 MB, it is renamed as MESSAGES.1 and a new MESSAGES.LOG file is then created.

Parameter value	Level of detail of reports
0	no messages
1	few details
...	
5	all messages



Real time timings can be impaired from a level of detail of 4.

System parameter P11 (Bluetooth ID no.)

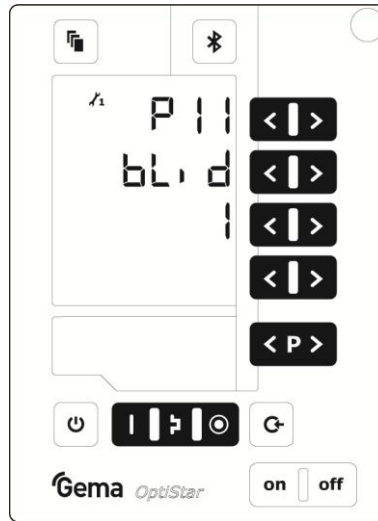

fig. 18: System parameter P11

The Bluetooth ID number is determined with this parameter. An individual Bluetooth ID number must be assigned to each pistol control unit that is to be accessed via the Gema electrostatic app.



This value is set to 0 in network operation.

- The Bluetooth function is disabled.
-



Pairing of the Bluetooth module with a mobile device

The first connection setup in which Bluetooth devices are coupled is also called pairing.

Following conditions have to prevail:

- the E-App has already been downloaded and installed from an app distribution platform ( or ) (Keyword "**gema e-app**").
- ID number set in system parameter P11.
- Bluetooth activated on mobile device

To use Gema's E-App, proceed as follows:

1. Start the E-App
2. Keep the  key on the control unit pressed for two seconds
3. Press 
4. Select OptiStar
 - the control unit is now paired. The communication partners exchange key data so that they automatically recognize each other next time.

Further information on how to use Gema's e-app can be found either on the website www.gemapowdercoating.com or in the E-App under the heading "**Service**".

CAN bus

General

The control unit is a simple CANopen slave. It operates in a network with a central control unit (Master). Communication takes place exclusively between the Master and the Slaves.

Following data can be accessed by CANopen:

- All desired values (process data)
- All actual values (process data)
- All control values
- All system parameters (except Baud rate and CAN address)
- All error messages
- All special parameters such as software version, daily correction, powder output correction etc.

Hardware

The OptiStar control units are connected to the central PLC control unit via 4 pin CAN bus cables. The last bus client is fitted with a terminal plug with terminal resistor in order to terminate the network correctly. A maximum of up to 127 MultiStar Control units can be operated in a network.

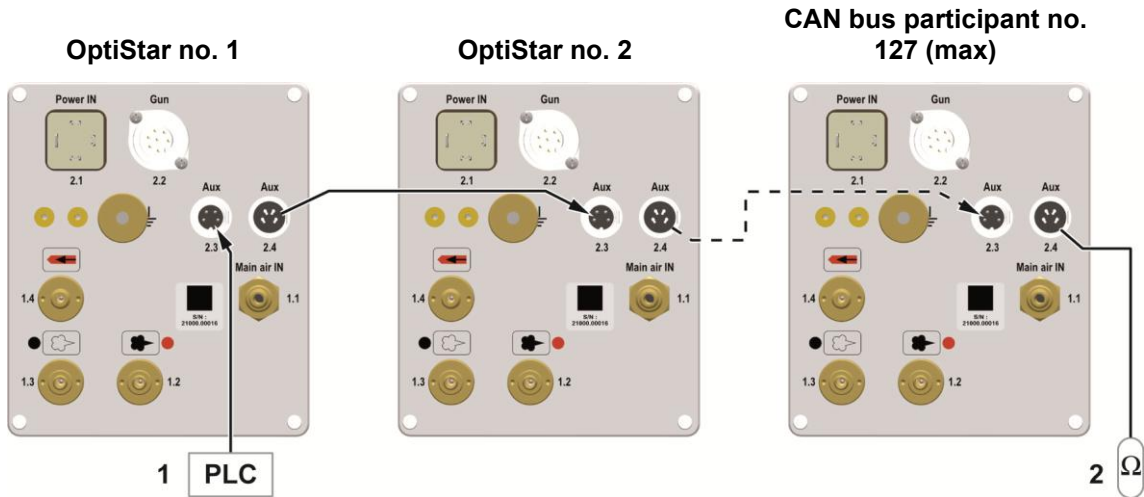

fig. 19: CAN bus – connections

- 1 PLC control with CAN bus
- 2 Terminal resistor

CAN bus cable – plug assignment

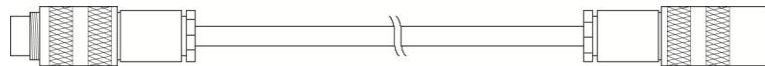

fig. 20: CAN bus cable

Pin	Signal	Color
1	GND	white
2	+24 VDC	black
3	CAN H	black
4	CAN L	black

Determining device address (Node-ID) and Baud rate

Each device (user), which operates on the CAN network, must have an individual user address (Node-ID) assigned. The Baud rate setting enables the transmission speed setting. The Baud rate value may be set by editing the system parameter P05, and the Node ID value may be set by editing the system parameter P06.

Node ID – system parameter P06

CAN Node ID 1-127

P06 value	CAN Node ID
1-127	1-127

Baud rate – system parameter P05

P05 value	Baud rate
0	20 kbit/s
1	50 kbit/s
2	100 kbit/s
3	125 kbit/s
4	250 kbit/s
5	500 kbit/s
6	800 kbit/s
7	1 Mbit/s

Default value of system parameter P05 = 3

The Baud rate is selected with 125 kbits as default. This setting permits a maximum cable length of approx. 500 m from the first to the last CAN bus user. If longer cables are used, select a lower Baud rate.

Operation

Operation





During the initial commissioning of the device, the functional check must be performed without powder!

Select predefined operating mode (Preset mode)

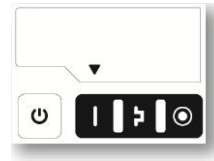
1. Turn on the gun control unit with the **ON** key
2. Press the corresponding application key.
The arrow above the desired button lights up.



The pre-defined application modes have preset values for high voltage and spray current:

Application mode		Preset kV	Preset μ A
	flat parts	100	100
	complicated parts	100	22
	overcoat	100	10

3. The air values for total air, powder output and electrode rinsing air can be individually defined and are saved in the programs.

Starting the individual adjustable programs

1. Turn on the gun control unit with the **ON** key
2. Press the **< P >** program key
3. Select the desired program (001-250)







Program 250 active

4. Change the coating parameters as required



Programs 001-250 are preset at the factory but can be modified at any time, after which they are automatically stored.

Description		Presetting
	Powder output	60 %
	Total air	4.0 Nm ³ /h
	High voltage	80 kV
	Spray current	20 µA
	Electrode rinsing air	0.1 Nm ³ /h

Setting powder output and powder cloud

The powder output depends on the selected powder output (in %), and the powder cloud on the selected total air volume.



As a factory default value, a powder rate of 60% and a total air volume of 4 Nm³/h are recommended.

- If values are entered that the gun control unit cannot implement, then the operator is informed of this by a blinking in the relevant display and a temporary error message!

Setting the total air volume



Adjust the total air volume on the gun control unit with the **T3/T4** keys

- Adjust the total air volume according to the corresponding coating requests

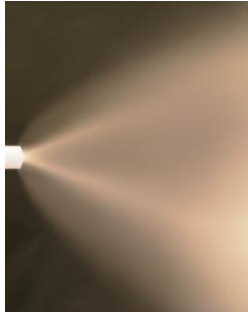

correct powder cloud



too little total air

Setting the powder output



much powder



little powder

Adjust the powder output volume (e.g. according to the desired coating thickness)

- Factory default setting of 60% is recommended for initial operation. The total air volume is thereby kept constant automatically by the control unit.



To achieve maximum efficiency, we recommend using the lowest possible powder volume where possible!

2. Check fluidization of the powder in the powder container
3. Point the gun into the booth, switch the gun on and visually check the powder output

Setting the electrode rinsing air

1. Press the  key.
The second display level will be shown.



Adjust the correct electrode rinsing air according to the applied nozzles (deflector plate, flat jet nozzle)

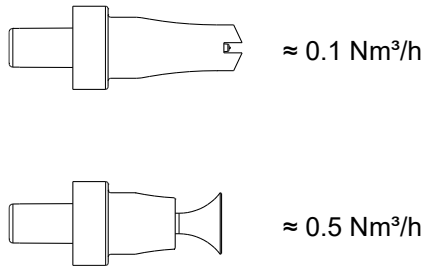

too much electrode rinsing air

3. If in this display level is no operation for 3 seconds, the display will automatically switch back to main default display level.

Remote operation

There is the possibility to remotely control the device externally via CAN-Bus.

Local operation in remote operating mode

In remote operating mode, local operation is limited to:

- Display of desired values of the current program
- Displaying the actual values
- Error acknowledgement

Transfer to remote operating mode

- During transfer from local to remote operating, and vice versa, the powder output will cease, so that the device is in a defined mode after transfer.
- Remote operating mode is signaled by the symbol S12 (**remote**).

System release in network operation

The system release logic starts and stops the powder conveying and high voltage. The release is determined due to the several internal and external signals.

Signal	Designation
Trigger	Gun connected
External release	Release on mains plug
	Gun release on control unit
Gun release	Command via Remote Interface
Error lock	Device error
System lock	Parameter input

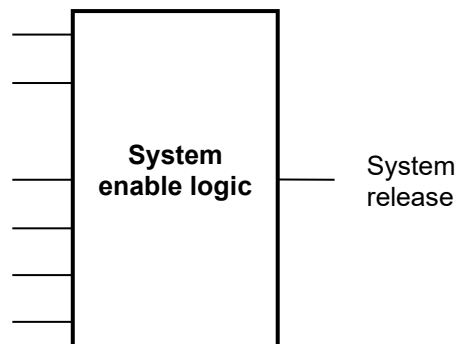

Correction values

With the correction values, the gun control unit can be adapted optimally to local conditions (e.g. the adjustment of different powder outputs in the plant).

ATTENTION

Incorrectly set correction values can lead to coating errors

The plant was optimally set by the Gema service engineer at the first start-up.

- Changes of correction values may only be made by Gema trained personnel.

Entering the correction values

1. Hold the  key down for 5 seconds

The display switches to the following level:

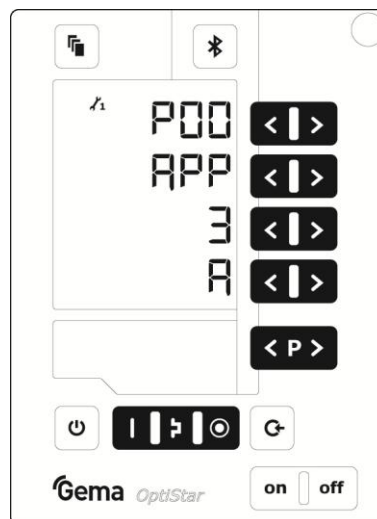

2. Push the  key

The display switches to the following level:

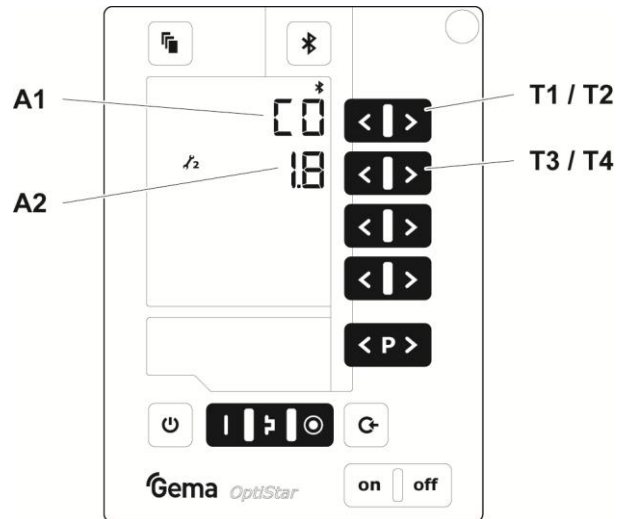

3. The correction factor number is shown in the display **A1** with a **C** placed in front
4. Set the corresponding correction value with the **T3** or **T4** key.
- The value of the adjusted correction factor appears on corresponding display **A2**
5. Scroll to the next or previous correction factor with the **T1** or **T2** key
6. Select correction values according to the following table

Correction value	Description	Range ²⁾	Default value
C0	Powder offset (Nm ³ /h)	0.5-3.0	1.8 ¹⁾
C1	Powder hose correction value (%)	40-100	100
C2	Daily correction value (%)	50-150	100
C10	Powder hose length (m)	6-18	12 ³⁾
C11	Powder hose diameter (mm)	10-12	11 ³⁾

¹⁾ Any correction value is set to its default value if the default value changes when the P00 device type is changed.

²⁾ A correction value is set to its default value if it is outside of the value range after the P00 device type has been changed.

³⁾ The more precise these settings are, the more precisely the calculated powder output can be shown in the Gema E-App.

7. Push the  key

The display returns to the first level display.

Powder output/powder hose correction





The settings in the following example are carried out for each gun individually!

Powder output corrections are made at the first start-up, after a service work, after the solution of application problems, or by using different hose diameters!

It is recommended to create a table with input fields (see "Example table for powder output/powder hose correction"), so that, if a possible system reset takes place, an access to these data can take place.

Powder output correction – procedure

1. Set the total air to **4.0** (Nm³/h) on the **A2** display. Set the powder output to **00** (%) on the **A1** display
2. To enter the system parameter mode, press the  key longer than 5 seconds.
3. Press the  key
The display switches to the correction factor level. The correction factor number is shown in the display **A1** with a **C** placed in front
4. Check the correction value for minimum powder output **C0** on the **A2** display, and set it to **1.8** (Nm³/h) with the **T3/T4** keys if necessary
5. Check the correction value for maximum powder output **C1** on the **A2** display, and set it to **100** (%) if necessary



For the next steps a measuring bag is necessary, for weighing the powder output.

- Do not forget to note the dead weight of the measuring bag.

6. Put the measuring bag over the gun nozzle and fasten it. Switch on the gun for 60 seconds
7. After this time has elapsed, switch off the gun, remove the measuring bag and weigh it. The powder output should be between 10-15 gr
8. If no powder is expelled from the gun, return to the system parameter mode and increase the minimum powder output value **C0** (range **0.5-3.0** Nm³/h)
9. If too much powder is expelled from the gun, return to the system parameter mode and decrease the minimum powder output value **C0** (range **0.5-3.0** Nm³/h)
10. Repeat steps 6 and 7, until the powder output amounts to 10-15 g. Annotate the adjusted minimum powder output value **C0** in the table

Exit the system parameter mode by pressing the  key.

Powder hose correction – procedure

1. Set the powder output value to **80 (%)** on the **A1** display
2. Put the measuring bag over the gun nozzle and fasten it. Switch on the gun for 60 seconds
3. Switch off the gun after 60 seconds, remove the measuring bag and weigh it
4. Annotate the powder output in **g/min** in the table

Calculate the powder output correction according to following formula:

$$C1 (\%) = \frac{\text{smallest powder output}}{\text{measured powder output}} \times 100$$

5. Annotate the calculated values (**C1**) for each individual gun in the table and enter the values to the control unit (therefore, repeat the steps 2 and 3)

Example table for powder offset and powder hose correction

Gun	Powder offset correction C0			
No.	Before correction		After correction	
1	C0=1.8 Nm ³ /h	20 g	C0=1.7 Nm³/h	12 g
2	C0=1.8 Nm ³ /h	10 g	C0=1.8 Nm³/h	13 g
3	C0=1.8 Nm ³ /h	0 g	C0=2.6 Nm³/h	12 g
etc.				

Gun	Powder hose correction C1			
No.	Before correction		After correction	
1	C1=100 %	200 g	C1=100 %	200 g
2	C1=100 %	250 g	C1=80%	200 g
3	C1=100 %	280 g	C1=71%	200 g
etc.				

Correction factor – diagram

Impact of the powder hose correction
(powder hose 11 mm x 12 m)

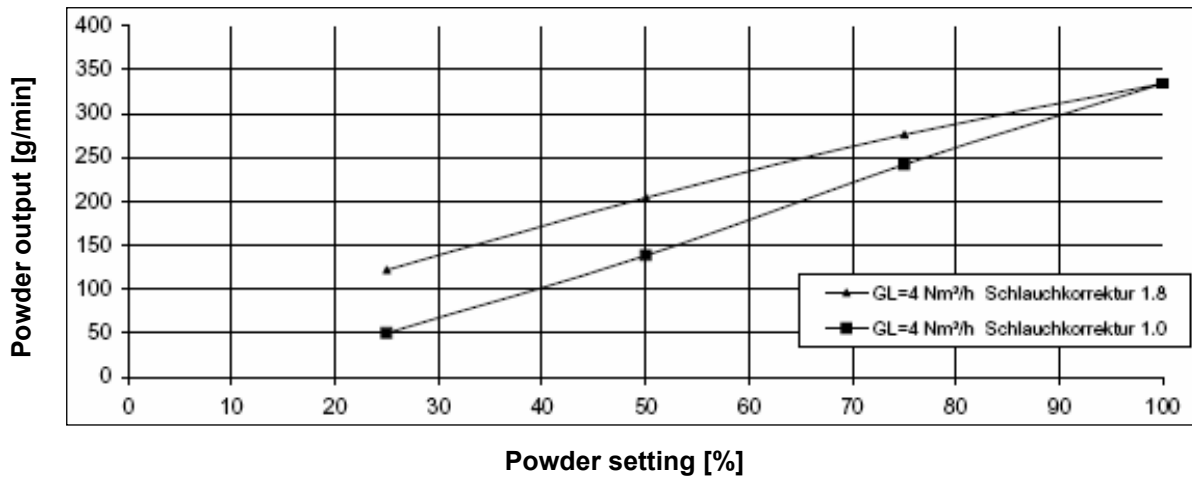

Fig. 21: Correction factor – diagram



The hose length correction factor is chosen in such a way, that no powder is visible, if the powder portion is 0%, by increasing the value, the powder becomes visible then.

- This performance depends on the hose length and the hose diameter!

Daily correction value C2

The daily correction value C2 can be used to allow higher or lower powder volumes!

Rinsing mode

The rinsing mode enables the blowing off of powder accumulations in the powder hose with preset air pressure and can also be activated via the CAN bus connection – see also the MagicControl 4.0 operating instructions.

This function is a two steps process to activate.

Activating the rinsing function

The rinsing mode can only be activated from standby mode (main menu display, no powder conveying). The prerequisite is, that all necessary release signals are present.

⚠ CAUTION

Release of pulsating and/or compressed air containing powder.

If the product is operated without the appropriate equipment (hearing protection, safety goggles) and not in front of an appropriately dimensioned suction unit, the compressed air containing powder can cause hearing damage, eye damage as well as respiratory problems.

- ▶ The powder hose and the pneumatic hoses must be mounted.
- ▶ The gun must be held in the direction of an appropriately dimensioned suction unit (such as Gema Classic Open booth) (targeted discharge of the compressed air energy).
- ▶ Wearing appropriate protective equipment is mandatory.

ATTENTION



During the rinsing process, a potentially damaging situation arises.

- ▶ The injector must be detached prior to rinsing procedure!

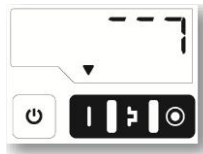
1. Press the  rinse key



- 2.
3. Select the rinsing function

Key	Rinsing function
	Powder hose cleaning with increasing air volume
	Powder hose cleaning with constant air volume

The selected function is marked in blue by the triangle symbol.

4. During the “Powder hose cleaning with increasing air volume” mode, all airflows are increased step by step after starting the rinsing procedure, and then they remain at the maximum:

Time [s]		0	1	2	3	4...
Conveying air	[Nm ³ /h]	0	2	4	5.5	5.5
Supplementary air	[Nm ³ /h]	0	1.5	3.0	4.5	4.5
Electrode rinsing air	[Nm ³ /h]	0	1.0	2.0	3.0	3.0

- During the “Powder hose cleaning with constant air volume” mode, there is no airflow increasing step by step. The maximum values are set immediately.

The rinsing mode is exited:

- if no operation is started within 15 s (not in Remote operation mode)
- if the rinsing sequence has finished

The active rinsing function is terminated immediately when exiting this mode.

The rinsing mode is terminated by pressing the  key.

Setting the background illumination

- Press the  key

The display switches to the following level:



-  * 5 

Select the desired brightness

Checking the software version

- Press these two keys at the same time

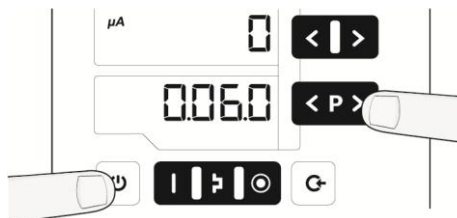

- The status display is shown as long as the keys are held.

Checking the trigger time

1. Press these two keys at the same time

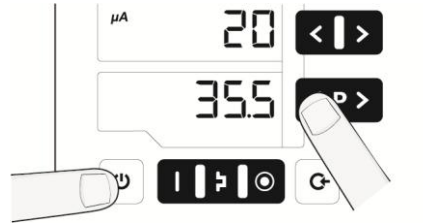

- The trigger counter (total time in days of trigger time) is shown in the display (e.g. 35.5 days = 852 h).

The status display is shown as long as the keys are held.



The trigger counter can't be reset!

RAM Reset

The RAM reset enables a restore of factory settings of the gun control unit. All parameters (**except P00**) and correction values as well as all user-defined values in the Program mode and Preset mode will be overwritten with factory default values. An active keyboard lock will be deactivated.



By resetting the RAM, all user-made settings will be set to factory default!

1. Switch off the device
2. Press the  key and hold it
3. Switch on the control unit, the **CLR** display blinks

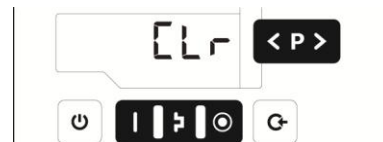

4. Wait for approximately 5 seconds until **CLR** disappears
5. Release the  key
 - All values are reset. The control unit must be set-up again.

Decommissioning / Storage

Shutdown

1. End the coating procedure
2. Switch off the control unit



The adjustments for high voltage, powder output volume and electrode rinsing air remain stored.

When the product will not be used for several days

1. Switch off the power to the control unit at the main switch
2. Clean the gun and the components for powder conveying (see therefore the corresponding user manuals)
3. Turn off the compressed air main supply

Storage conditions

Hazard notes

There is no danger to personnel or the environment if the unit is stored properly.

Type of storage

The product must be stored horizontally for safety reasons.

Storage duration

If the physical conditions are maintained, the unit can be stored indefinitely.

Space requirements

The space requirements correspond to the size of the product.

There are no special requirements concerning distance to neighboring equipment.

Physical requirements

Storage must be inside a dry building at a temperature between +5 and +50 °C. Do not expose to direct sunlight!

Maintenance during storage

Maintenance schedule

No maintenance schedule is necessary.

Maintenance works

During long-term storage, periodically perform a visual check.

Maintenance / Repairs

General information

The product was designed for a maintenance-free operation.

Periodic checks

The periodic checks include examining all connecting cables and hoses.

The corresponding parts should be replaced immediately if any damage to cables or hoses is discovered.

All plugs must be properly tightened.

Repair work

In the event of malfunctions or faults, the product must be checked and repaired at an authorized Gema service location. The repairs must only be performed by an authorized specialist.

Improper interventions can result in serious danger for user or the equipment and may result in loss of warranty!

Troubleshooting

Error diagnosis of the software

General information

The correct function of the Gun control unit is constantly monitored. If the equipment software determines a fault, an error message is indicated with a help code. Following is monitored:

- High voltage technology
- Pneumatic system
- Power supply

Help codes

The error diagnosis codes (help codes) are shown in red on the **A5** display.

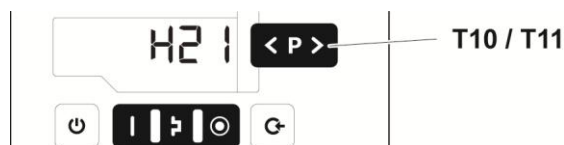

The help codes are stored in an error list in the order of their appearance. Each error in the list must be individually acknowledged with the keys **T10** or **T11**.

The errors are displayed in the order of their appearance. The **T10** and **T11** keys cannot be used for other functions, as long as an error code is still shown.

Here is a list of all possible help codes for this Gun control unit:

Code	Description	Criteria	Remedy
Pneumatics:			
H06	Trigger valve	Solenoid coil current lower than preset limiting value Valve defective, main board or cable defective	Contact a Gema service center

Code	Description	Criteria	Remedy
H07	Supplementary air volume too high (setting of supplementary air on the display)	The preset value for supplementary air is too high compared to the conveying air setting	Lower supplementary air value or increase value for conveying air to equalize air volumes to the injector, delete error code
H08	Conveying air volume too high (setting of powder share on the display)	The preset value for conveying air is too high compared to the supplementary air setting	Lower conveying air value or increase value for supplementary air to equalize air volumes to the injector, delete error code
H09	Powder output higher than 100%	The powder output multiplied by the powder hose length factor and daily correction value is greater than 100% Daily correction value too large	Reduce powder output Reduce daily correction value
H10	Conveying air range lower deviation	The theoretical value for conveying air falls below minimum Total air is smaller than minimum	Limit conveying air to its minimum value
High voltage:			
H11	Gun error	No vibrations in the oscillator, cable break, oscillator or gun is defective	Contact a Gema service center
H13	Gun Overload	Cable or cascade defective. The control unit is switched off.	Contact a Gema service center
Power supply:			
H20	Voltage supply error Mainboard	Mainboard defective	Contact a Gema service center
H21	Supply undervoltage	Power pack defective or overloaded	Contact a Gema service center
H22	Wrong internal system clock	Backup battery is empty	Contact a Gema service center
EEPROM (equipment memory):			
H24	EEPROM content invalid	EEPROM error	Contact a Gema service center
H25	Timeout during EEPROM writing	EEPROM error	Contact a Gema service center
H26	Values not correctly stored in EEPROM during switching off	EEPROM error	Contact a Gema service center
H27	EEPROM verification erroneous	EEPROM error	Contact a Gema service center
CAN bus:			
H40	Permanent CAN bus error	The CAN controller changes into BUS OFF condition. No power supply or cable is not connected.	Connect the cable, otherwise contact Gema service

Code	Description	Criteria	Remedy
H41	High error rate when transmitting/receiving	The CAN controller changes into ERROR_PASSIVE condition	Contact a Gema service center
H42	Overflow on data reception	The message to be received has no more place in the receiver buffer. Messages are sent faster than they can be processed.	Contact a Gema service center
H43	Overflow on transmission	The message to be sent has no more place in the transmission buffer. Messages are produced faster than they can be sent.	Contact a Gema service center
H44	Master failed	Node Guarding message is missing longer than 2 seconds. Connection to master failed.	Check the connection to the Master, otherwise contact Gema service
H45	Parameter value outside the value range	The sent parameter value is outside the allowed value range	Check input values
H46	Invalid Node ID set	The Node ID is not between 1 and 127	Set Node ID to 127
H47	No CAN interface installed	CAN interface is selected in the system parameters, but no interface is installed	Contact a Gema service center
H48	No ACK to "Boot Up Message" received	No CAN node is answering to the "Boot Up Message".	Check cabling connections between the users, otherwise contact Gema service

Throttle motors:

H60	Conveying air reference position not found	Throttle motor or needle jammed, limit switch defective, error in motor throttle	Contact a Gema service center
H61	Supplementary air reference position not found	Throttle motor or needle jammed, limit switch defective, error in motor throttle	Contact a Gema service center
H62	Electrode rinsing air reference position not found	Throttle motor or needle jammed, limit switch defective, error in motor throttle	Contact a Gema service center
H64	Conveying air throttle does not move	Short circuit in limit switch, motor throttle defective	Contact a Gema service center
H65	Supplementary air throttle does not move	Short circuit in limit switch, motor throttle defective	Contact a Gema service center
H66	Electrode rinsing air throttle does not move	Short circuit in limit switch, motor throttle defective	Contact a Gema service center
H68	Conveying air position lost	Lost steps, limit switch defective, throttle motor defective	Contact a Gema service center
H69	Supplementary air position lost	Lost steps, limit switch defective, throttle motor defective	Contact a Gema service center
H70	Electrode rinsing air position lost	Lost steps, limit switch defective, throttle motor defective	Contact a Gema service center

Communication mainboard-gun:

H91	Communication error mainboard-gun	Gun, gun cable or Mainboard defective	Replace or contact Gema Service
-----	-----------------------------------	---------------------------------------	---------------------------------

Help codes list

The last appeared four errors are stored in a list by the software. If an error appears, which is already in the list, he will not be listed again.

Appearance of errors

It is possible that a help code is only displayed for a short time, but after the acknowledgment it will disappear. In this case, it's recommended to switch off the device and switch it on again (reset by restarting).

Disposal

Introduction

Requirements on personnel carrying out the work

The disposal of the product is to be carried out by the owner or operator.

When disposing of components that are not manufactured by Gema, the instructions in the respective manufacturer's documentation must be observed.

Disposal regulations



The product must be disassembled and disposed of properly at the end of its service life.

- ▶ When disposing of the product, the applicable local and regional laws, directives and environmental regulations must be complied with!
-

Materials

The materials must be sorted according to material groups and taken to the appropriate collection points.

Disassembly of component groups

WARNING

Live components

Risk of fatal injury from electric shock if touched

- ▶ Only trained, authorized staff may open the electrical compartment
 - ▶ Observe the safety symbols
-

1. Disconnect the mains supply and supply cables.
2. Remove all product covers.

The product is now prepared for disassembly.

Spare parts list

Ordering spare parts

When ordering spare parts for your product, please indicate the following specifications:

- Type and serial number of your product
- Order number, quantity and description of each spare part

Example:

- **Type** Gun control unit OptiStar 4.0 (CG20/-C)
Serial number 1234 5678
- **Order no.** 203 386, 1 piece, Clamp – Ø 18/15 mm

When ordering cable or hose material, the required length must also be given. The spare part numbers of this bulk stock is always marked with an *.

The wearing parts are always marked with a #. marked.

All dimensions of plastic hoses are specified with the external and internal diameter:

Example:

Ø 8/6 mm, 8 mm outside diameter (o/d) / 6 mm inside diameter (i/d)

⚠ WARNING

Use of non-original Gema spare parts

Use of Non-Gema replacement spare parts may invalidate some or all approval certificates and accreditations; and the user assumes all explosion risks associated with use of these parts. Use of these replacement spare parts may void any and all warranty claims.

- ▶ Use only original Gema spare parts!

OptiStar CG20(-C) gun control unit

	OptiStar CG20 gun control unit – complete, without item 4	1015 201
	OptiStar CG20-C gun control unit – complete, without item 4	1015 202
1	Front plate – complete, see corresponding spare parts list	
2	Enclosure	
3	Backplate – complete, see corresponding spare parts list	
4	Cover	1015 249



fig. 22

Front plate and power pack

	Front plate – complete (pos. 1-12)	1015 219
	Front plate with foil keyboard (pos. 5-8)	1015 218
1	OptiStar Mainboard – complete	1015 221
2	Spacer sleeve – Ø 3.1/6x15 mm	
3	PCB "Powerboard" – complete	1015 223
4	Spacer sleeve – Ø 3.2/6x7 mm	
5	Front frame – complete (incl. pos. 5.1)	1015 232
5.1	Screw	1007 019
6	Screw – M4x16 mm	1013 925
7	Front plate gasket	1015 236
8	Membrane keypad with carrier plate	1015 217
9	Spacer sleeve – Ø 3.6/7x5 mm	
10	Display	1015 220
11	Washer – Ø 3.2/7x0.5 mm	
12	Locknut – M3	
13	Power pack – 24 VDC	1009 849

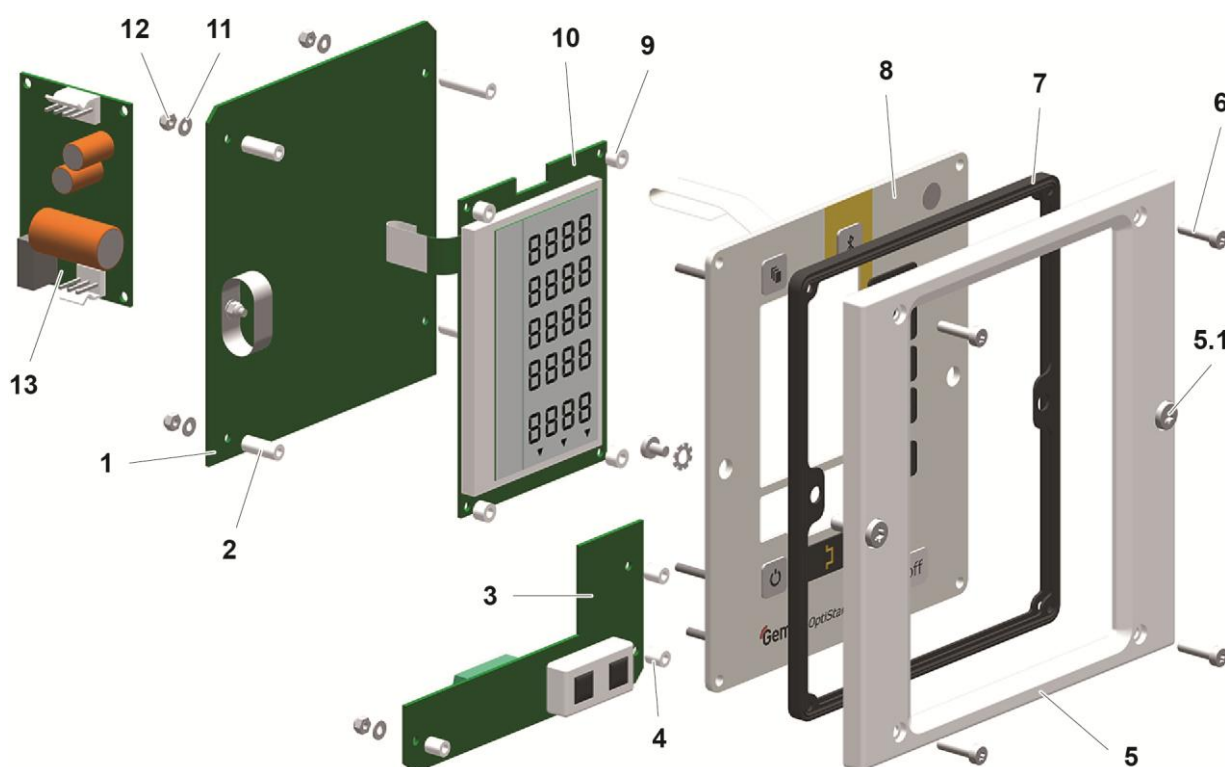

Fig. 23

Inside back plate

1	Back plate gasket	1015 198
2	CAN bus module – complete	1015 234
3	Elbow plug-in connection – Ø 8-Ø 8 mm	230 995
4	Solenoid valve – Ø 8-Ø 8 mm, 24 VDC	1003 914
5	O-ring – Ø 12x1.5 mm, NBR70	261 416
6	Motor throttle – complete	1000 064
7	O-ring – Ø 8x4 mm, NBR70	1001 521
8	Fluidizing pad – 1/8"	237 264
9	Screw – M4x16 mm	1013 925
10	Plastic tube – Ø 8/6 mm	103 152*

* Please indicate length

Inside back plate

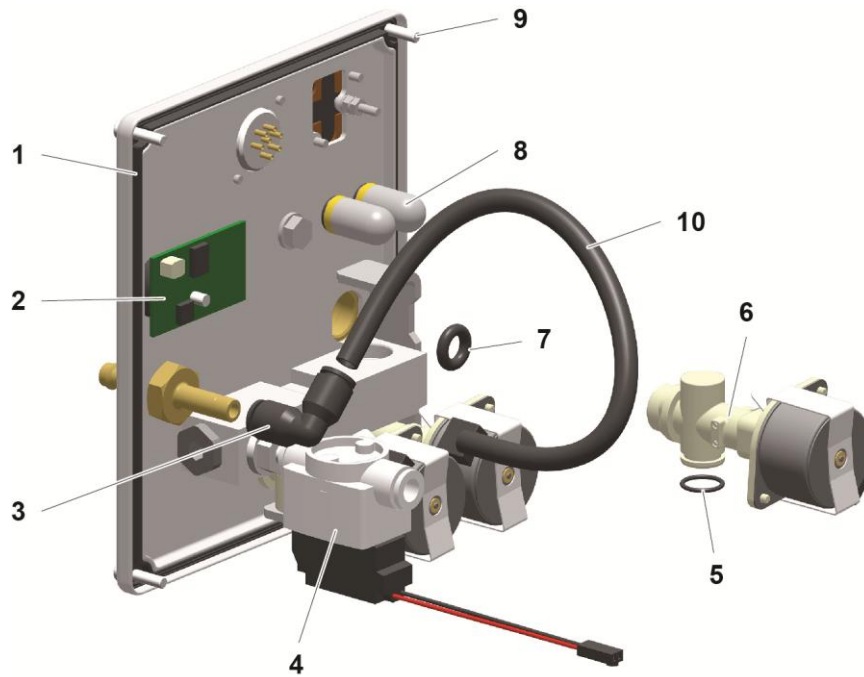

Fig. 24: OptiStar CG20-C

Connecting material

1	Quick release connection – NW5, Ø 6 mm	200 840
1.1	Hose – Ø 6/4 mm	103 144*
2	Nut with kink protection – M12x1 mm, Ø 8 mm	201 316
2.1	Supplementary air hose – Ø 8/6 mm (black)	103 756*
2.2	Quick release coupling for supplementary air hose – NW5-Ø 8 mm	261 637
3	Nut with kink protection – M12x1 mm, Ø 8 mm	201 316
3.1	Conveying air hose – Ø 8/6 mm (red)	103 500*
3.2	Quick release coupling for conveying air hose – NW5-Ø 8 mm	261 645
4	Quick release connection – NW5-Ø 8 mm	203 181
4.1	Hose – Ø 8/6 mm	103 756*
6	CAN bus cable – 0.5 m	1002 655
	CAN bus cable – 4.5 m	387 592
	CAN bus cable – 5.5 m	388 521
	CAN bus cable – 6.0 m	388 530
7	Bus terminal resistor (not shown)	387 606
8	Connecting cable – 12 pins, 1.5 m	1000 991
	Connecting cable – 12 pins, 2.2 m	393 398
	Connecting cable – 12 pins, 5 m	1000 975
	Connecting cable – 12 pins, 10 m	1000 976
	Connecting cable – 12 pins, 15 m	1000 977
	Connecting cable – 12 pins, 20 m	1000 978
9	Mains cable – 4.5 m	1002 563

* Please indicate length

Connecting material

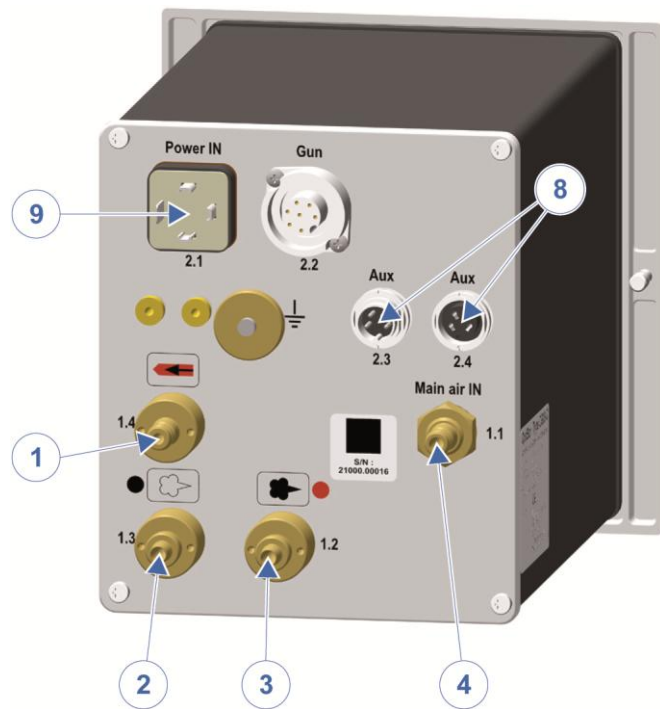

Fig. 25

Index

A

About these instructions	7
Assembly	29

B

Basic safety instructions	11
Bluetooth ID no.	36

C

Compressed air hoses / cables	23
Connectable guns	15
Connection	29
Connection instructions	30
Connections	23

D

Decommissioning	55
Design and function	19
Dimensions	16
Disassembly of component groups	63
Disposal	63
Disposal regulations	63
Disuse for several days	55

E

E-App	27
Pairing	37
Electrical data	15
Environmental conditions	18

F

Figure references in the text	8
-------------------------------------	---

G

Guidelines, European	14
----------------------------	----

I

Input keys and switches	22
Intended use	13

M

Maintenance	57
Maintenance during storage	56

O

Operating elements	20
Displays	20
Input keys and switches	22
Operating modes	25
Operation	41
Overall view	19

P

PCC mode	26
Periodic checks	57
Pictograms	7
Pin assignment	24
Pneumatic data	16
Powder output (reference values)	16
Presentation of the contents	8
Preset mode	25
Product description	13
Product specific security regulations	11
Program mode	26

R

Rating plate	18
Repair work	57
Repairs	57

S

Safety	11
Safety symbols	7
Scope of delivery	24
Shutdown	55
Sound pressure level	18
Spare parts list	65
Standards, European	14
Start-up	31
Storage	55

Storage conditions	55	Typical characteristics	25
T		V	
Troubleshooting	59	Versions	15

