

Operating instructions and Spare parts list

Gun control unit OptiStar CG12-CP

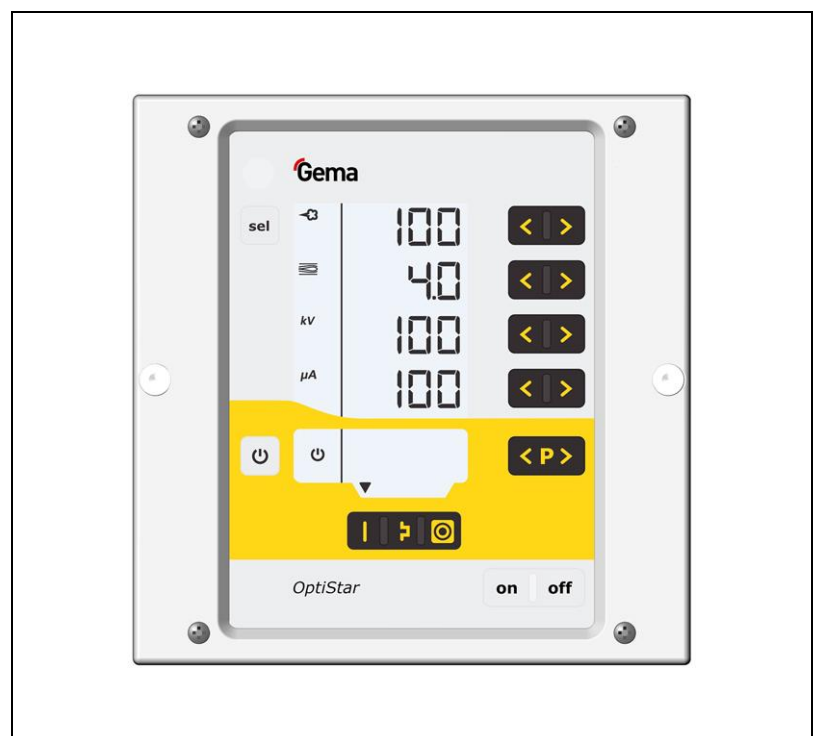

Translation of the original operating instructions

Documentation OptiStar CG12-CP

© Copyright 2017 Gema Switzerland GmbH

All rights reserved.

This publication is protected by copyright. Unauthorized copying is prohibited by law. No part of this publication may be reproduced, photocopied, translated, stored on a retrieval system or transmitted in any form or by any means for any purpose, neither as a whole nor partially, without the express written consent of Gema Switzerland GmbH.

Gema, EquiFlow, MagicCompact, MagicCylinder, OptiCenter, OptiFlex, OptiGun, OptiSelect, OptiStar, OptiStar All-in-One and PowerBoost are registered trademarks of Gema Switzerland GmbH.

ClassicLine, ClassicStandard, ClassicOpen, DVC (Digital Valve Control), GemaConnect, MagicControl, MagicPlus, MonoCyclone, MRS, MultiColor, MultiStar, OptiAir, OptiControl, OptiColor, OptiFeed, OptiFlow, OptiHopper, OptiMove, OptiSieve, OptiSpeeder, OptiSpray, PCC (Precise Charge Control), RobotGun, SIT (Smart Inline Technology) and SuperCorona are registered trademarks of Gema Switzerland GmbH.

All other product names are trademarks or registered trademarks of their respective holders.

Reference is made in this manual to different trademarks or registered trademarks. Such references do not mean that the manufacturers concerned approve of or are bound in any form by this manual. We have endeavored to retain the preferred spelling of the trademarks, and registered trademarks of the copyright holders.

To the best of our knowledge and belief, the information contained in this publication was correct and valid on the date of publication. Gema Switzerland GmbH makes no representations or warranties with respect to the contents or use of this publication, and reserves the right to revise this publication and make changes to its content without prior notice.

For the latest information about Gema products, visit
www.gemapowdercoating.com.

For information regarding patents, see
www.gemapowdercoating.com/patents or
www.gemapowdercoating.us/patents.

Gema Switzerland GmbH
Mövenstrasse 17
9015 St.Gallen
Switzerland

Phone: +41-71-313 83 00

Email: info@gema.eu.com

Table of contents

About these instructions	7
General information	7
Keeping the Manual	7
Safety symbols (pictograms).....	7
Structure of Safety Notes	8
Software version	8
Presentation of the contents	8
Figure references in the text	8
Safety	11
Basic safety instructions	11
Product specific security regulations	11
Product description	13
Intended use	13
Reasonably foreseeable misuse	14
Technical Data	14
Connectable guns	14
Electrical data	14
Pneumatic data	15
Dimensions	15
Powder output (reference values).....	15
Air flow rates	15
Sound pressure level	16
Rating plate	16
Design and function	17
Overall view.....	17
Operating elements.....	18
Connections	21
Scope of delivery.....	23
Typical properties – Characteristics of the functions	23
Operating modes	23
Cleaning mode	25
Monitoring of wearing parts.....	25
Background illumination	26
Assembly / Connection	27
Assembly guide.....	27
Connection instructions.....	28
Start-up	31
Preparation for start-up	31
Basic conditions	31
System parameters	31
Entering the system parameters	31
CAN bus.....	35
General	35

Hardware	36
Determining device address (Node-ID) and Baud rate	37
Operation	39
Operation	39
Starting the individual adjustable programs	40
Setting powder output and powder cloud	40
Setting the spraying air	42
Setting the electrode rinsing air	42
Pinch valves and system backpressure monitoring display	43
Remote operation	45
Local operation in remote operating mode	45
Transfer to remote operating mode	45
System release in network operation	45
Correction values	46
Entering the correction values	46
Cleaning mode	48
Activating the cleaning function	48
Monitoring of wearing parts and trigger counter	48
Trigger counter	49
View remaining service life	49
Deactivation of wearing part monitoring	50
Setting the background illumination	50
Checking the software version	51
RAM Reset	51
Decommissioning / Storage	53
Shutdown	53
When the product will not be used for several days	53
Storage conditions	53
Hazard notes	53
Type of storage	53
Storage duration	53
Space requirements	53
Physical requirements	54
Maintenance during storage	54
Maintenance schedule	54
Maintenance works	54
Maintenance / Repairs	55
General information	55
Periodic checks	55
Repair work	55
Troubleshooting	57
Error diagnosis of the software	57
General information	57
Help codes	57
Help codes list	60
Appearance of errors	60
Disposal	61
Introduction	61
Requirements on personnel carrying out the work	61
Disposal regulations	61
Materials	61

Disassembly of component groups	61
Spare parts list	63
Ordering spare parts	63
OptiStar CG12-CP Gun control unit.....	64
Front plate and power pack	65
Inside back plate	66
Connecting material	68
Index	71

About these instructions

General information

This operating manual contains all the important information that is needed to operate the OptiStar CG12-CP. It will safely guide you through the start-up process and give you references and tips for the optimal use when working with your powder coating system.

Information about the functional mode of the individual system components should be referenced in the respective enclosed documents.

Keeping the Manual

Please keep this Manual ready for later use or if there should be any queries.

Safety symbols (pictograms)

The following warnings with their meanings can be found in the Gema instructions. The general safety precautions must also be followed as well as the regulations in the relevant instructions.

DANGER

Indicates a hazardous situation, which, if not avoided, will result in death or serious injury.

WARNING

Indicates a hazardous situation, which, if not avoided, could result in death or serious injury.

CAUTION

Indicates a hazardous situation, which, if not avoided, could result in minor or moderate injury.

ATTENTION

Indicates a potentially harmful situation. If not avoided, the equipment or something in its surrounding may be damaged.

ENVIRONMENT

Indicates a potentially harmful situation, which, if not avoided, may have harmful consequences for the environment.

**MANDATORY NOTE**

Information that must be observed.

**NOTICE**

Useful information, tips, etc.

Structure of Safety Notes

Every note consists of 4 elements:

- Signal word
- Nature and source of the danger
- Possible consequences of the danger
- Prevention of the danger

⚠ SIGNAL WORD

Nature and source of the hazard!

Possible consequences of the danger

- ▶ Prevention of the danger

Software version

This document describes the operation of the product OptiStar CG12-CP with software version starting from 1.99.53.

See chapter "[Checking the software version](#)" on page 51.

Presentation of the contents

Figure references in the text

Figure references are used as cross references in the descriptive text.

Example:

"During the typical OptiCenter (7) operation, the powder bag is put in the powder bag cone. The powder is fluidized in the bag with the fluidizing/suction lance and then fed to the OptiSpeeder (9). The fluidized powder is sucked in by the conveyors and fed through the powder hoses to the guns/spray nozzles (8). The powder, which does not adhere to the workpieces, will be absorbed by the exhaust air of the booth (1) and separated from the air in the cyclone separator (2)."

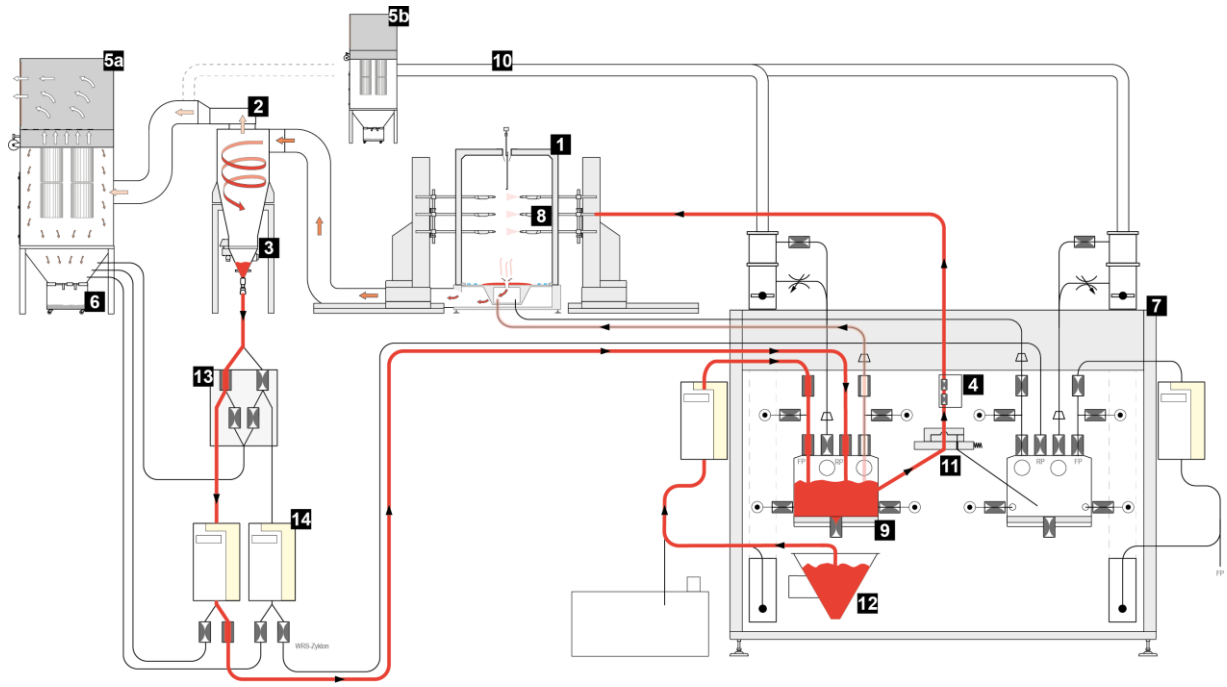

Safety

Basic safety instructions

- This product is built to the latest specification and conforms to the recognized technical safety regulations and is designed for the normal application of powder coating.
- Any other use is not considered as intended use. The manufacturer shall not be liable for damage resulting from such use; the user bears sole responsibility for such actions. If this product is to be used for other purposes or other substances outside of our guidelines then Gema Switzerland GmbH should be consulted.
- Start-up (i.e. the execution of intended operational tasks) is forbidden until it has been established that this product has been set up and wired according to the guidelines for machinery. The standard "EN ISO 12100 Machine safety" must also be observed.
Machine safety
- Unauthorized modifications to the product exempt the manufacturer from any liability from resulting damage.
- The relevant accident prevention regulations, as well as other generally recognized safety regulations, occupational health and structural regulations are to be observed.
- Furthermore, the country-specific safety regulations also must be observed.

Product specific security regulations

- This product is a constituent part of the equipment and is therefore integrated in the system's safety concept.
- If it is to be used in a manner outside the scope of the safety concept, then corresponding measures must be taken.
- The installation work to be done by the customer must be carried out according to local regulations.
- It must be ensured, that all components are earthed according to the local regulations before start-up.



For further security information, see the more detailed Gema safety regulations!

⚠ WARNING**Working without instructions**

Working without instructions or with individual pages from the instructions may result in damage to property and personal injury if relevant safety information is not observed.

- ▶ Before working with the device, organize the required documents and read the section "Safety regulations".
- ▶ Work should only be carried out in accordance with the instructions of the relevant documents.
- ▶ Always work with the complete original document.

Product description

Intended use

The Gun control unit is designed exclusively for controlling the Gema powder coating guns and the OptiSpray AP01 application pump (see also in chapter "Technical data").

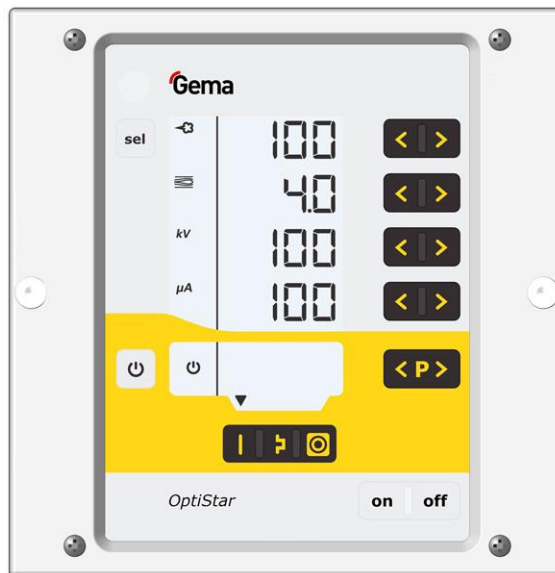

fig. 1

Up to 2 Application pumps can be controlled by this control unit:

- for supplying one powder gun with the powder (individual operation)
- to increase the supply rate (parallel operation).

The desired operation can be selected with the P09 system parameter (see also "Entering the system parameters").

Usually, this control unit is used in automatic plants in connection with the CM30 plant control. The real control of the application pump(s) as well as the error messages display are done on the CM30, then. The cleaning process too is initiated on the CM30.

Observance of the operating, service and maintenance instructions specified by the manufacturer is also part of conformity of use. This product should only be used, maintained and started up by trained personnel, who are informed about and are familiar with the possible hazards involved.

Any other use is considered non-compliant. The manufacturer is not responsible for any incorrect use and the risks associated with such actions are assumed by the user alone!

For a better understanding of the interrelationships in powder coating, it is recommended that the operating instructions for all other components be read as well, so as to be familiar with their functions too.

Reasonably foreseeable misuse

- Operation without the proper training
- Use with insufficient compressed air quality
- Use in connection with unauthorized coating devices or components

Technical Data



Connectable guns

OptiStar CG12-CP	connectable
OptiGun GA03-P	yes

ATTENTION

The gun control unit may only be used with the specified gun types!

Electrical data

OptiStar CG12-CP	
Nominal input voltage	100-240 VAC
Frequency	50-60 Hz
Connected load	40 VA
Nominal output voltage (to the gun)	12 V
Nominal output current (to the gun)	1.2 A
Protection type	IP54
Temperature range	0 °C - +40 °C (+32 °F - +104 °F)
Max. surface temperature	85 °C (+185 °F)
Approvals	 2813  II 3 (2) D PTB11 ATEX 5007-2

Pneumatic data

OptiStar	
Compressed air connection	Quick coupling
Inlet pressure	6.0 bar
Max. input pressure	10 bar / 145 psi
Min. input pressure (while unit in operation)	6.5 bar / 95 psi
Max. water vapor content of the compressed air	1.3 g/m ³
Max. oil vapor content of the compressed air	0.1 mg/m ³

Dimensions

OptiStar CG12-CP	
Width	173 mm
Depth	250 mm
Height	177 mm
Weight	approx. 3.7 kg

Powder output (reference values)

General conditions for the Application pump

Powder type	Epoxy/polyester
Length of powder hose (m)	20
Powder hose Ø (mm)	7
Type of powder hose	POE with guide strips
Input pressure (bar)	6.0
Correction value C0	9

Air flow rates

The total air consists of transport air and supplementary air, in relation to the selected powder quantity (in %). As a result the total air volume is maintained constant.

OptiStar	
Transport air flow rate	0-3.5 Nm ³ /h
Spraying air flow rate	0-4.5 Nm ³ /h
Electrode rinsing air flow rate	0-3.0 Nm ³ /h

▶ **The total air consumption for the device is determined based on the configured air values.**

- These values apply for an internal control pressure of 6.0 bar!

Sound pressure level

OptiStar CG12-CP	
Normal operation	< 60 dB(A)

The sound pressure level was measured while the unit was in operation; measurements were taken at the most frequent operator positions and at a height of 1.7 m from the ground.

The specified value is applicable only for this product itself and does not take into account external noise sources or cleaning impulses.

The sound pressure level may vary, depending on the product configuration and space constraints.

Rating plate

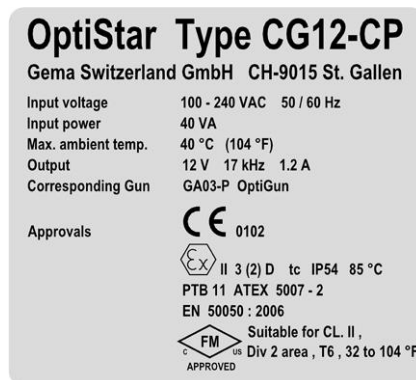

fig. 2

Operating elements

Displays



The desired and actual values are distributed across several levels.

- The "sel" key is used to switch between the levels.
- If no controls are used within 6 s, the device automatically returns to level 1.

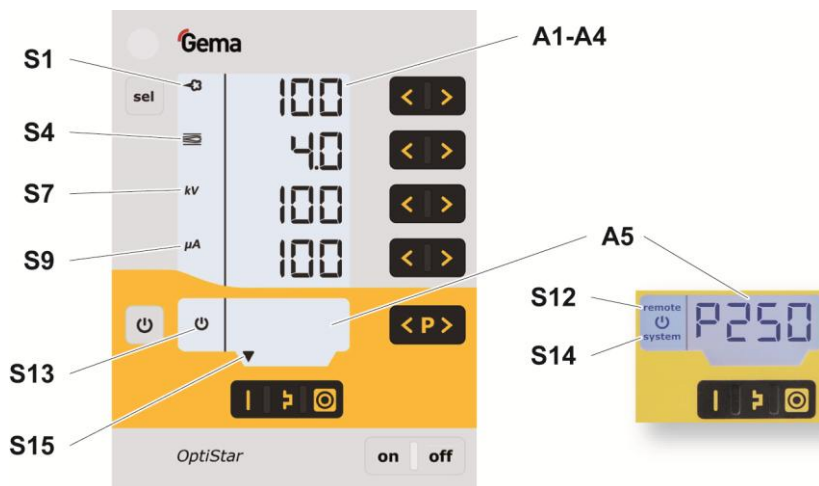

fig. 4: Displays, Level 1

Designation	Function
A1-A4	Display of actual values, desired values and system parameters <ul style="list-style-type: none"> - Flashes if the possible range is exceeded.
A5	Display of program numbers, error diagnosis codes and status information
S1	Powder output (display in %)
S4	Total air volume (display in Nm ³ /h)
S7	High voltage (display in kV)
S9	Spraying current (display in µA)
S12 remote	Remote operation mode, no local operation possible <ul style="list-style-type: none"> - Remote operation mode is used as keyboard lock, reduced operation is possible
S13	Gun release
S14 system	System release via external release
S15	Display of predefined operating modes or display of cleaning mode during cleaning

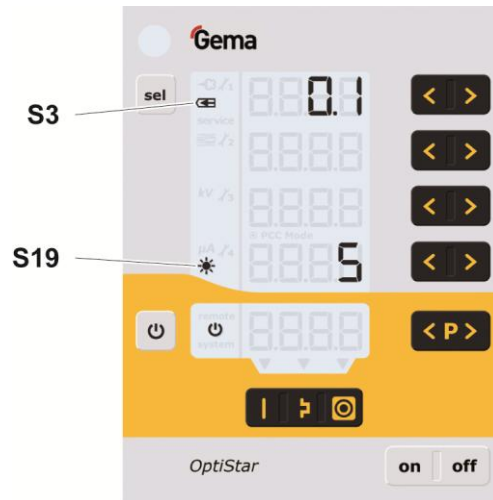

fig. 5: Displays and LEDs, Level 2

Designation	Function
S3	Electrode rinsing air (display in Nm ³ /h)
S19	Display illumination (0-8)

Input keys and switches

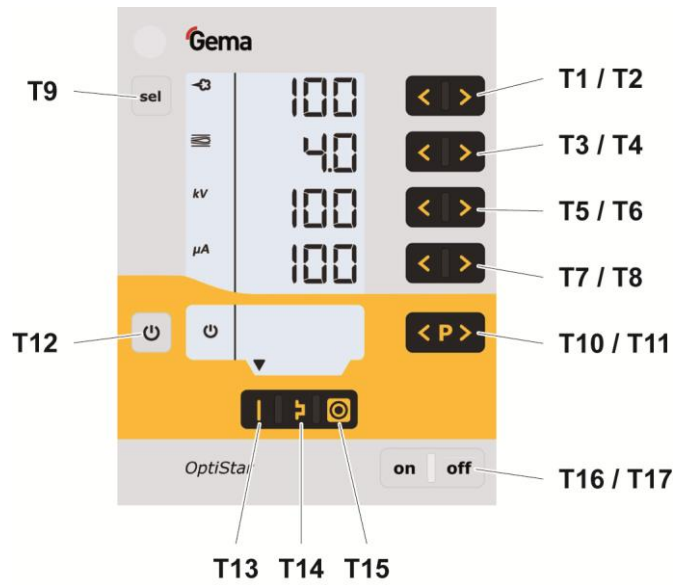

fig. 6: Input keys and switches





Designation	Function
T1-T8	Input keys for desired values and system parameters
T9 (Select)	Switch between display levels
T10-T11	Program change
T12	<ul style="list-style-type: none"> - Gun release - Switchover to system parameter mode (press for at least 5 secs.)
T13	Preset mode for flat parts (fixed values)
T14	Preset mode for complex parts with depressions (fixed values)
T15	Preset mode for overcoating parts already coated (fixed values)
T16/T17	Power switch On/Off

Connections

Compressed air hoses / cables



fig. 7: Connections

Connection	Description
1.1 Main air IN	Compressed air connection
2.1 Power IN	Mains cable connection
2.2 Gun	Gun cable connection
2.3 Aux	CAN bus connection (IN)
2.4 Aux	CAN bus connection (OUT)
2.5 Ext.	AP01 Application pump no. 1 connection
2.6 Ext.	AP01 Application pump no. 2 connection
1.2 	Transport air connection
1.3 	Spraying air connection
1.4 	Electrode rinsing air connection
1.6 	Pinch valve air connection
	Grounding connection

Pin assignment

Power IN



2.1

Power IN connection

- 1 Neutral conductor (power supply)
- 2 Phase (100-240 VAC)
- 3 External release (100-240 VAC)
- PE PE grounding

Gun

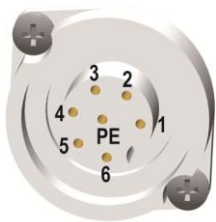

2.2

Gun connection

- 1 Ground
- 2 Remote control 1 (GM03)
- 3 Ground
- 4 Trigger
- 5 Remote control 2 (GM03)
- 6 Oscillator
- 7 PE grounding

Aux



2.3

CAN IN plug with 4 pins (2.3 Aux)

- 1 Ground
- 2 24 VDC
- 3 CAN high
- 4 CAN low
- Enclosure – shield

Aux



2.4

CAN OUT socket with 4 pins (2.4 Aux)

- 1 Ground
- 2 24 VDC
- 3 CAN high
- 4 CAN low
- Enclosure – shield

Ext.



2.5

Ext.



2.6

Connection Application pump 1 (2.5) and 2 (2.6)

- A-H Control signal
- J-M +24 VDC
- Body – grounding PE

Scope of delivery

- Power cable (country-specific)
- Quick-start guide and operating manual

Typical properties – Characteristics of the functions

Operating modes

The gun control unit has two operating modes.

Predefined operating mode (Preset mode)

The gun control unit has three preset application modes:

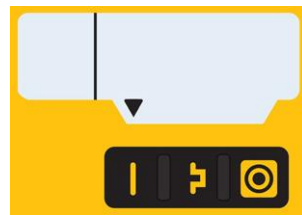

fig. 8



Application mode for flat parts

This application mode is suitable for the coating of simple, flat workpieces without larger cavities.



Application mode for complicated parts

This application mode is suitable for the coating of three-dimensional workpieces with complex shapes (e.g. profiles).



Application mode for recoating parts already coated

This application mode is suitable for the overcoating of workpieces which are already coated.

In this operating modes, current (μA) and high voltage (kV) are preset, while powder and air volumes can be set and stored for each application mode.

Adjustable operating mode (Program mode)

In this operating mode, 250 individually definable programs (P001-P250) are available. These programs are automatically saved and can be recalled again as the application requires.



fig. 9

The values for current, high voltage, powder output, total air and electrode rinsing air can be set as needed for a given application.



The settings defined in the 250 programs and 3 application modes are automatically stored, without confirmation!

Precise Control of spraying Current (PCC Mode)

For coating components with both complex and simple geometries, a spraying current of below 10 μA can be selected to prevent unintended overcoating on the simpler surfaces. This is especially important in combination with high loading powders (such as metallic). The controller automatically switches into "PCC mode". This allows for very fast yet highly precise control. The high voltage and spray current values and their symbols are depicted in red:



fig. 10: PCC mode

Cleaning mode

The Cleaning mode is used to blow powder accumulations out of the powder hose, application pump, and gun using compressed air. A pinch valve diagnostic is also integrated.



The cleaning mode can only be activated from standby mode, namely by pressing the corresponding keys on the gun control unit or also by an optional bus connection such as CAN bus.

The cleaning mode is signaled by a circling LCD segment on the display:



fig. 11: Cleaning mode

The actual rinsing procedure is started and stopped by the superordinated control unit.

Once the cleaning mode is quit, the unit automatically returns to the last program.

Monitoring of wearing parts

Wearing parts have a limited service life. The gun control unit offers functionality to monitor the service life of up to four wearing parts using a reverse counter:



fig. 12

To better explain this function, a few terms relevant to this process must first be explained:

Term	Explanation
Service life	Operating time after which wearing parts should be replaced (defined by the operator).
Minus days	Number of hours past the selected service life that the wearing part has continued to be used.
Operating life	Effective time during which the wearing part was in operation = service life plus minus days if any.
Remaining service life	displayed value (where not in the minus range)

- The service life monitoring can be activated/deactivated for each wearing part (see also "Initial start-up – Monitoring of wearing parts")
- By default, all monitoring is deactivated and must be activated by the operating company
- Query the remaining service life
- Reset the operating time
- Resolution used for display of service life/operating time: 1 day (x.x), range: 0,1 – 500 days

Example table:

No.	Wearing part
1	Filter element
2	Powder hose
3	Electrode holder
4	Pinch valve hose

Background illumination

Brightness

8 different brightness settings are available for the display. The setting remains in place when the machine is switched on/off.



fig. 13

Auto Power Save mode

If no powder is being applied, then the background lighting turns off automatically 5 minutes after a button has been pressed last time.

Assembly / Connection

Assembly guide

The gun control unit is mounted into place using 2xM6 screws on the front side.



fig. 14

Connection instructions

The Gun control unit and the Application pump(s) are supplied ready for use by the manufacturer. Just a few cables and hoses must be connected.

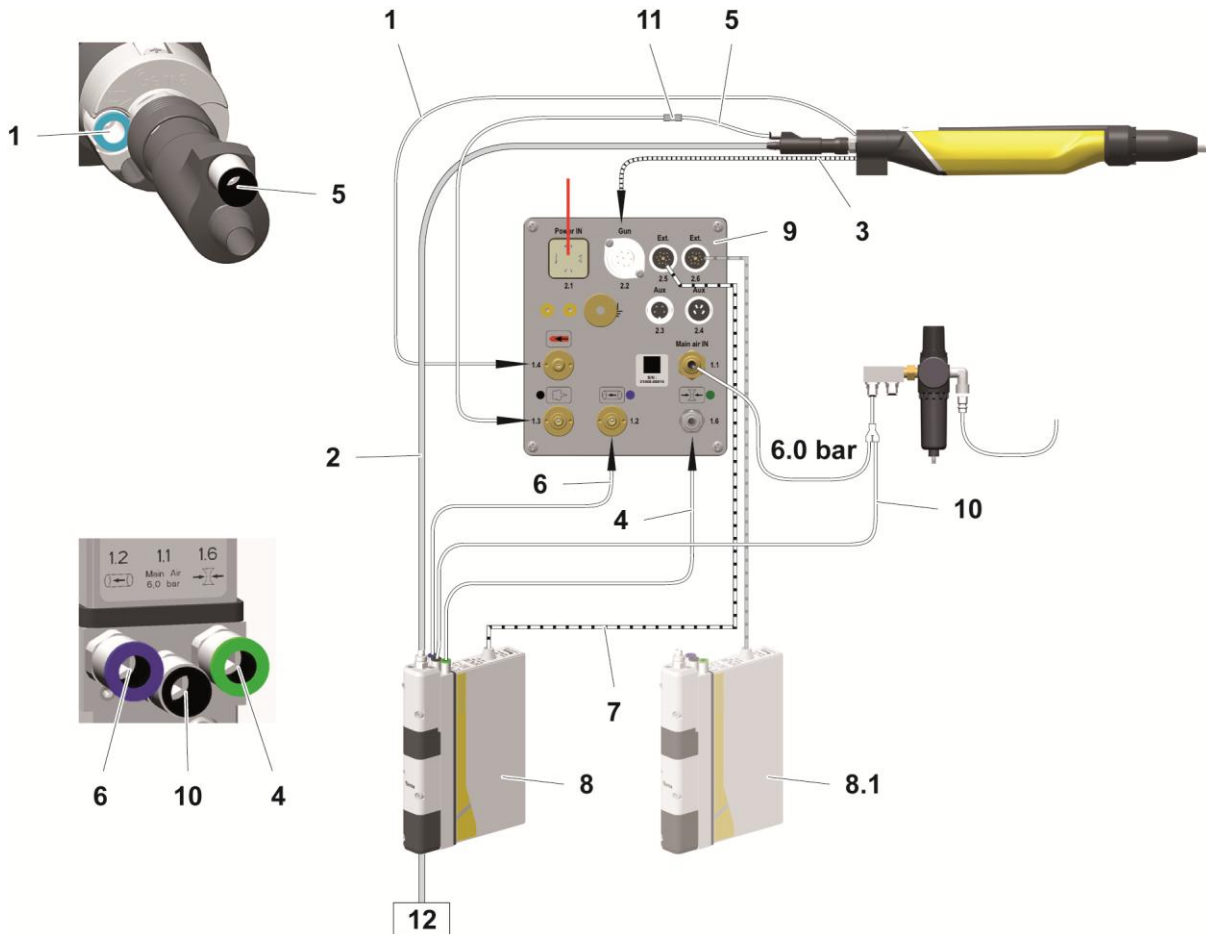

fig. 15: Connecting guide – overview

- | | | | |
|---|----------------------------|-----|-----------------------------------|
| 1 | Electrode rinsing air hose | 8 | Application pump no. 1 |
| 2 | Powder hose | 8.1 | Application pump no. 2 |
| 3 | Gun cable | 9 | Gun control |
| 4 | Pinch valve air | 10 | Compressed air hose |
| 5 | Spraying air hose | 11 | Hose coupling Ø 8/6 –
Ø 6/4 mm |
| 6 | Transport air hose | 12 | Powder hopper |
| 7 | Control signal cable | | |



Connect grounding cable to the booth or the suspension arrangement!



- Check ground connections with Ohm meter and ensure 1 MOhm or less.



The source electrical connections for the Control Units are to be connected in an unclassified location only.



The compressed air must be free of oil and water!



Close the unused connections with the provided dust protection caps!



Start-up

Preparation for start-up



The gun control unit always starts up to the last configured settings.

Basic conditions

When starting up the gun control unit, the following general conditions impacting the coating results must be taken into consideration:

- Gun control unit correctly connected
- Gun correctly connected
- Corresponding power and compressed air supply available
- Powder preparation and powder quality

System parameters

The Gun control unit is configured by using the system parameters. This configuration will be saved in the equipment memory. These values can be adjusted and requested manually or by remote interface (CAN).

Entering the system parameters

1. Turn on the gun control unit with the **ON** key
2. Hold  key down for 5 seconds
 - The display switches to the following level:

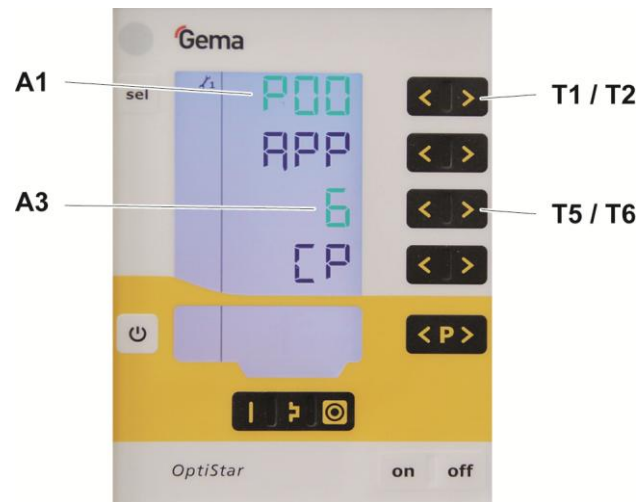

3. The system parameter number is shown in the display **A1** with a **P** placed in front
4. Set the corresponding system parameter value with the **T5** or **T6** key.
 - The value of the adjusted system parameter appears on corresponding display **A3**
5. Scroll to the next or previous system parameter with the **T1** or **T2** key



Selection is cyclical, i.e. after the last system parameter, the first starts again and vice versa.

6. Select parameter values according to the following table

No.	Description	Values	Display
P00¹⁾	Device type	0: Fluidizing device Type F (CG13)	F
		1: Box device with vibrator Type B (CG13)	B
		2: Stirrer device Type S (CG13)	S
		3: Automatic device (CG08-C)	A
		4: Manual device with fluidization (CG13)	H Fd
		5: Application pump (CG11-P)	P
		6: Application pump + CAN-Bus (CG12-CP)	CP
P02	Inlet pressure	0: P in = 5.5 bar 1: P in = 6 bar 2: P in = 6.5 bar	5.5 6.0 6.5
P03	Unit of measurement (air)	0: Nm³/h 1: scfm	nn3 scf

No.	Description	Values	Display
P04	Interface type	0: Deactivated 1: Automatic recognition	OFF Auto
P05	CAN Baud rate	0: 20 kbit/s 1: 50 kbit/s 2: 100 kbit/s 3: 125 kbit/s 4: 250 kbit/s 5: 500 kbit/s 6: 800 kbit/s 7: 1 Mbit/s	2 0 5 0 1 0 0 1 2 5 2 5 0 5 0 0 8 0 0 1 0 0 0
P06	CAN Node ID	1-127	
P07	Reserve		
P08	Procedure when changing Local / Remote	0: Gun release is reset 1: Gun release is not changed	RCHG
P09	Pump operating mode	0: Individual operation 1: Parallel operation	SoLo dUo
P10	Log level	0, 1, 2 , 3, 4, 5	LoG

¹⁾ is not overwritten, if a Memory Reset is performed
Default values are marked by **bold** print.

7. Press  key to quit the system parameter mode.
The display switches to the standard level

System parameter P00 (device type)



fig. 16: System parameter P00

ATTENTION

A wrong parameterization leads to various malfunctions!

- The system parameter P0 must be set to 6 (Application pump + CAN bus)!

System parameter P03 (measuring unit)



fig. 17:

This parameter is used to determine the measuring unit for all airs (total air and electrode rinsing air). If the parameter is set to **1 (scfm)**, then all air values are shown in this measuring unit. These lines are displayed in **blue**.

System parameter P10

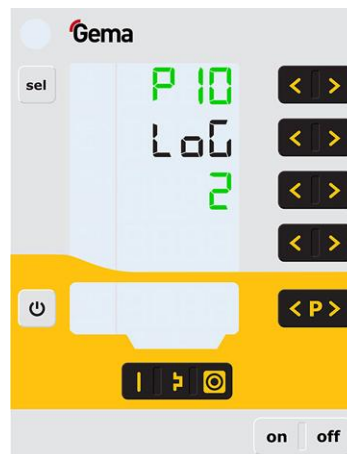

fig. 18: System parameter P10

The device can export log reports of the program run to an SD card for test purposes and for finding defects.

If an SD card is inserted during the switching on procedure, the log messages are also recorded onto the SD card. The data are record in the MESSAGES.LOG file in the root directory. Once this file reaches a size of 32 MB, it is renamed as MESSAGES.1 and a new MESSAGES.LOG file is then created.

Parameter value	Level of detail of reports
0	no messages
1	few details
...	
5	all messages



Real time timings can be impaired from a level of detail of 4.

CAN bus

General

The control unit is a simple CANopen slave. It operates in a network with a central control unit (Master). Communication takes place exclusively between the Master and the Slaves.

Following data can be accessed by CANopen:

- All desired values (process data)
- All actual values (process data)
- All control values
- All system parameters (except Baud rate and CAN address)
- All error messages
- All special parameters such as software version, daily correction, powder output correction etc.

Hardware

The OptiStar control units are connected to the central PLC control unit via 4 pin CAN bus cables. The last bus client is fitted with a terminal plug with terminal resistor in order to terminate the network correctly. A maximum of up to 127 MultiStar Control units can be operated in a network.

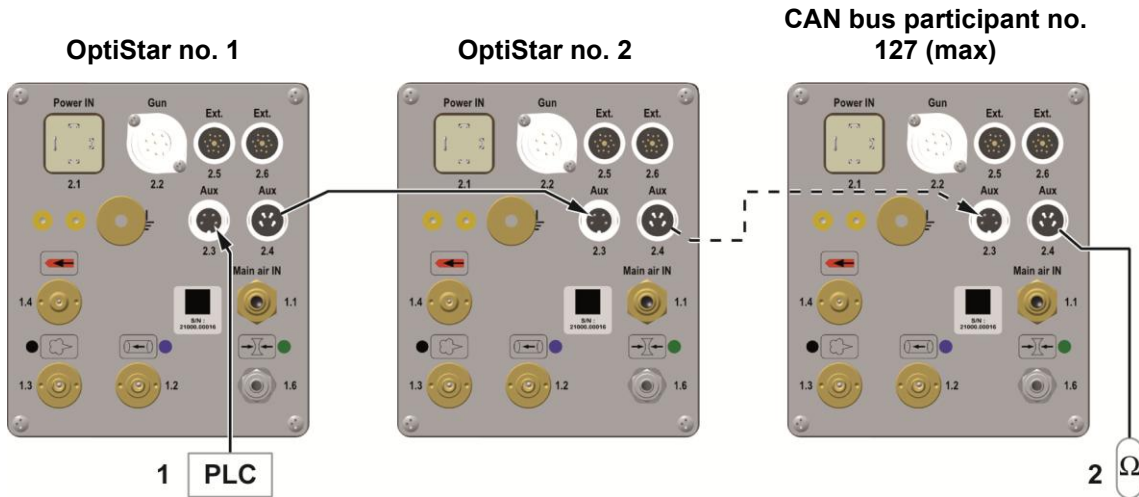

fig. 19: CAN bus – connections

- 1 PLC control with CAN bus
- 2 Terminal resistor

CAN bus cable – plug assignment

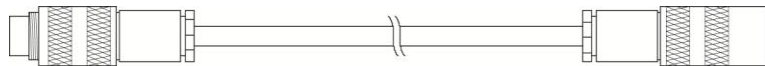

fig. 20: CAN bus cable

Pin	Signal	Color
1	GND	white
2	+24 VDC	black
3	CAN H	black
4	CAN L	black

Determining device address (Node-ID) and Baud rate

Each device (user), which operates on the CAN network, must have an individual user address (Node-ID) assigned. The Baud rate setting enables the transmission speed setting. The Baud rate value may be set by editing the system parameter P05, and the Node ID value may be set by editing the system parameter P06.

Node ID – system parameter P06

CAN Node ID 1-127

P06 value	CAN Node ID
1-127	1-127

Baud rate – system parameter P05

P05 value	Baud rate
0	20 kbit/s
1	50 kbit/s
2	100 kbit/s
3	125 kbit/s
4	250 kbit/s
5	500 kbit/s
6	800 kbit/s
7	1 Mbit/s

Default value of system parameter P05 = 3

The Baud rate is selected with 125 kbits as default. This setting permits a maximum cable length of approx. 500 m from the first to the last CAN bus user. If longer cables are used, select a lower Baud rate.

Operation

Operation



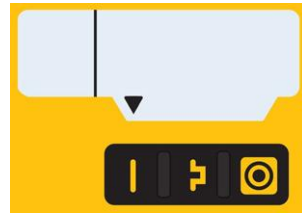

During the initial commissioning of the device, the functional check must be performed without powder!

1. Turn on the gun control unit with the **ON** key
2. Press the corresponding application key.
The arrow above the desired button lights up.



The pre-defined application modes have preset values for high voltage and spray current:

Application mode		Preset μA	Preset kV
	flat parts	100	100
	complicated parts	22	100
	overcoat	10	100

3. The air values for total air, powder output and electrode rinsing air can be individually defined and are saved in the programs.

Starting the individual adjustable programs

1. Turn on the gun control unit with the **ON** key



2. Press the  program key
3. Select desired program (001-250 / 01-20)







Program 250 active

4. Change coating parameters as required



Programs 001-250 (01-20) are preset at the factory but can be modified at any time, after which they are automatically stored.

Description		Presetting
	Powder output	60 %
	Total air	4.0 Nm ³ /h
	High voltage	80 kV
	Spray current	20 µA
	Electrode rinsing air	0.1 Nm ³ /h

Setting powder output and powder cloud

The powder output depends on the selected powder output (in %), and the powder cloud on the selected total air volume.



The Application pump should be operated with powder at least 1/2 hour after starting up.

- After the running-in of the filter elements a stable powder output value will be reached.



As a factory default value, a powder rate of 60% and a total air volume of 4 Nm³/h are recommended.

- If values are entered that the gun control unit cannot implement, then the operator is informed of this by a blinking in the relevant display and a temporary error message!

Setting the total air volume



1. Adjust the total air volume on the gun control unit with the **T3/T4** keys
- Adjust the total air volume according to the corresponding coating requests



correct powder cloud

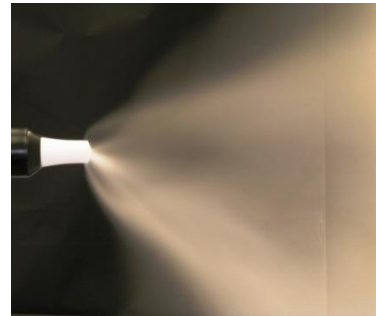

too little total air

Setting the powder output



much powder



little powder

Adjust the powder output volume (e.g. according to the desired coating thickness)

- Factory default setting of 50% is recommended for initial operation. The total air volume is thereby kept constant automatically by the control unit.



To achieve maximum efficiency, we recommend avoided an overly high powder volume where possible!

2. Check fluidization of the powder in the powder container
3. Point the gun into the booth, switch the gun on and visually check the powder output

Setting the spraying air

The spraying air (ZL) will be set in accordance to the calculated transport air (TL) and the adjusted total air volume (GL).

Formula:

$$GL = ZL + TL$$

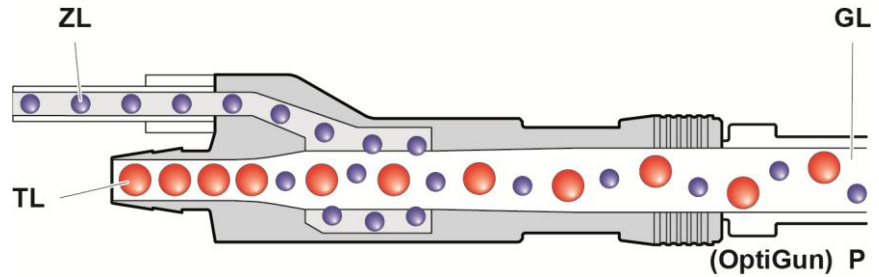

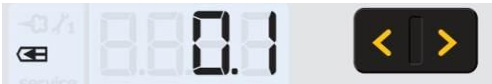

fig. 21: Air streams in the diffuser adapter

GL	Total air	TL	Transport air
ZL	Spraying air	P	Gun

Setting the electrode rinsing air

- Press the  key.
The second display level will be shown.
- 

Adjust the correct electrode rinsing air according to the applied nozzles (deflector plate, flat jet nozzle)

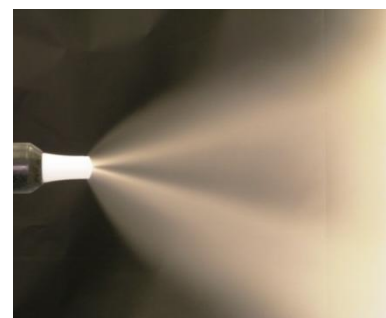
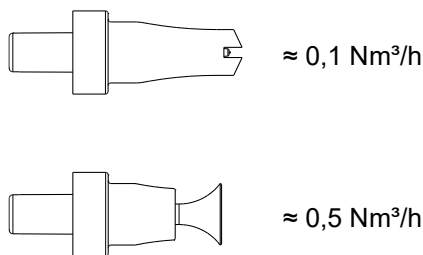

too much electrode rinsing air

- If in this display level is no operation for 3 seconds, the first display level is switched over independently.

Pinch valves and system backpressure monitoring display

1. Turn on the gun control unit with the **ON** key

2. Hold  key down for 5 seconds

The display switches to the following level:

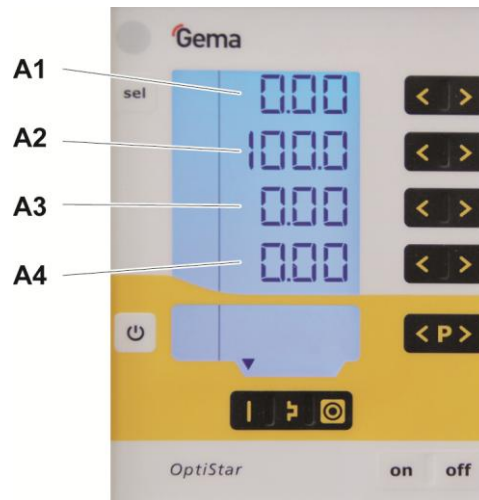

Display	Description	Unit
A1	Current pinch valves pressure	bar
A2	Opening time of control solenoid valve for pinch valves pressure (leak-tightness control)	%
A3	System backpressure 1	bar
A4	System backpressure 2	bar

3. Press  key 1x

The display switches to the following level:

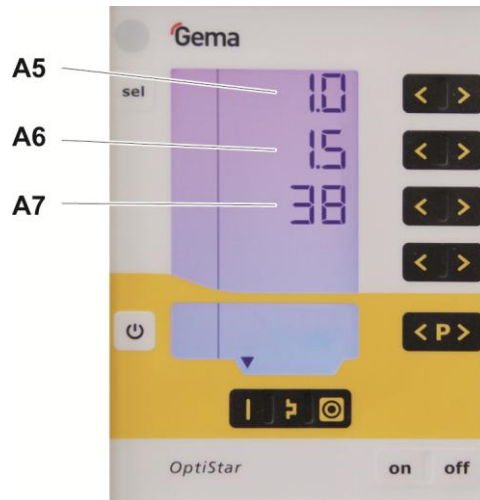

Display	Description	Unit ¹⁾
A5	Current transport air	Nm ³ /h
A6	Current spraying air	Nm ³ /h
A7	Pressure drop per each pinch valve closing	mbar/bar

1) Depending on the unit set, airflows are displayed in Nm³/h or scfm.

- Press  key 2x
The display switches to the main level



Remote operation

There is the possibility to remotely control the device externally via CAN-Bus.

Local operation in remote operating mode

In remote operating mode, local operation is limited to:

- Display of desired values of the current program
- Displaying the actual values
- Error acknowledgement

Transfer to remote operating mode

- During transfer from local to remote operating, and vice versa, the powder output will cease, so that the device is in a defined mode after transfer.
- Remote operating mode is signaled by the symbol S12 (**remote**).

System release in network operation

The system release logic starts and stops the powder conveying and high voltage. The release is determined due to the several internal and external signals.

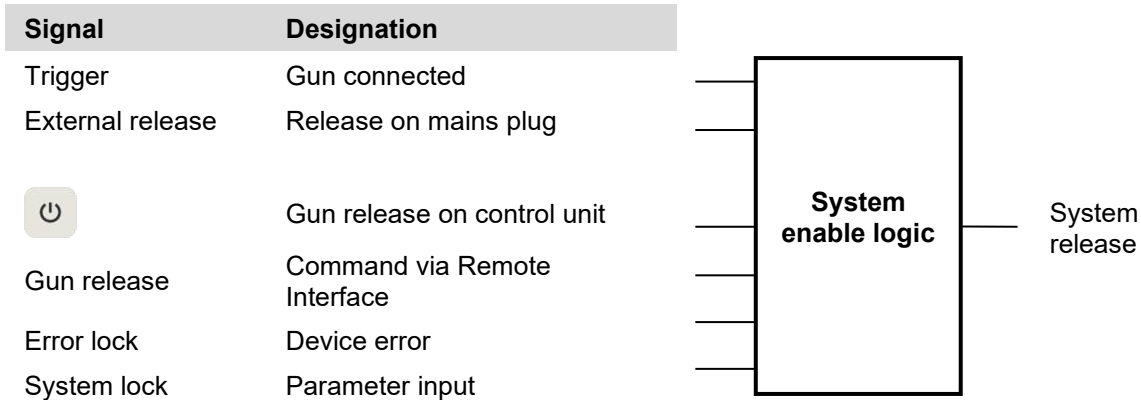

Correction values

With the correction values, the gun control unit can be adapted optimally to local conditions (e.g. the adjustment of different powder outputs in the plant).

ATTENTION

Incorrectly set correction values can lead to damage to the Application pump

The plant was optimally set by the Gema service engineer at the first start-up.

- Changes of correction values may only be made by Gema trained personnel.

Entering the correction values

1. Hold the  key down for 5 seconds

The display switches to the following level:



2. Press the  key

The display switches to the following level:

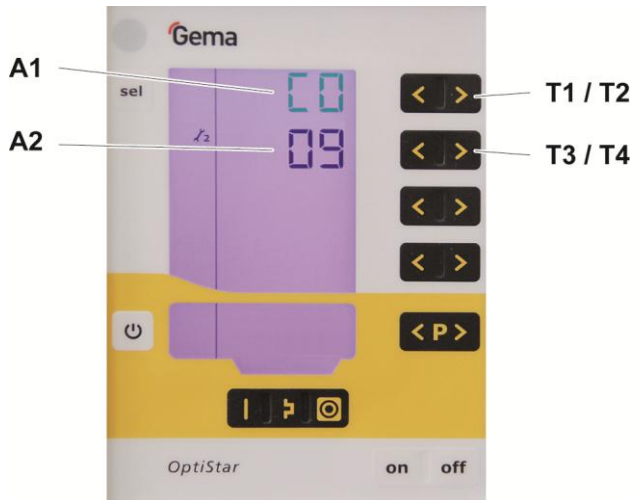

3. The correction factor number is shown in the display **A1** with a **C** placed in front
4. Set the corresponding correction value with the **T3** or **T4** key.
The value of the adjusted correction factor appears on corresponding display **A2**
5. Scroll to the next or previous correction factor with the **T1** or **T2** key
6. Select correction values according to the following table

Corr. value	Description	Range	Default values	
			Standard	Special ⁴⁾
C0	Minimum suction time (%)	0 -18	9 ¹⁾	12 ¹⁾
C1	Powder hose correction value (%)	40 -100	80	90
C2	Daily correction value (%)	50 -150	100	100
C3	Transport air offset (Nm ³ /h)	0 -2.0	1.0 ²⁾	1.0 ²⁾
C4	Pump operating frequency (Hz)	1.0 – 10.0	6.0 ³⁾	6.0 ³⁾
C5	Pinch valves set pressure Conveying mode (bar)	1.0 – 6.0	2.5	2.5
C6	Pinch valves set pressure Cleaning mode (bar)	1.0 – 6.0	4.5	4.5
C7	Back flushing T1 (%)	0 – 18	0 ¹⁾	6 ¹⁾
C8	Back flushing T2 (%)	0 – 18	0 ¹⁾	2 ¹⁾
C9	Permissible compressed air consumption (mbar/bar) = Threshold value for error message H89	0 – 200	70	70

- 1) The adjustment range applies to the half cycle time.
- 2) Depending on the unit set, airflows are displayed and entered in Nm³/h or scfm.
- 3) Do not change!
- 4) Use only if blockings occur.

7. Press the key
The display returns to the first level display.

Cleaning mode

The cleaning mode enables blowing off powder accumulations in the powder hose with preset air pressure, and is activated via the CAN bus – see the MagicControl CMxx operating instructions.

Activating the cleaning function

The cleaning mode can only be activated from standby mode (main menu display, no powder conveying). The prerequisite is, that all necessary release signals are present.

* Disabled in network operation

⚠ WARNING

Release of strong and pulsating compressed air containing powder.

If the pump is operated without the appropriate equipment (hearing protection, safety goggles and not in front of an appropriately dimensioned suction unit), the compressed air containing powder can cause hearing damage, eye damage as well as respiratory problems.

- ▶ The powder hoses on the suction and conveyance side must be mounted and held in the direction of an appropriately dimensioned suction unit (such as Gema Classic Open booth) (targeted discharge of the compressed air energy).
- ▶ Wearing appropriate protective equipment is mandatory.

Monitoring of wearing parts and trigger counter

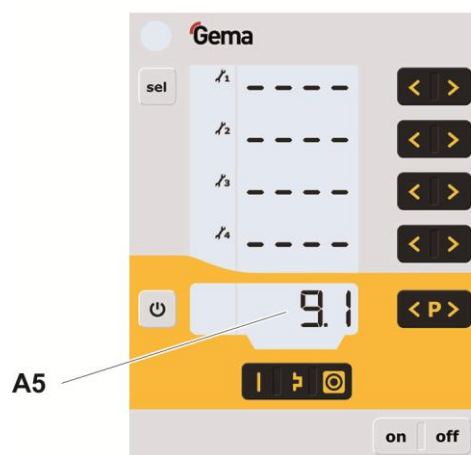

1. Press  key 2x

The display switches to the following level:



2. Press the  and  keys at the same time
Monitoring is activated

During the first activation a value of 0.1 is shown as the start value. If monitoring has already been activated at some earlier point, then the last stored value is displayed.

3. Set the desired service life for each wearing part using the  or 
4. The reverse counter is then activated and runs only during active coating
5. If the selected service life is exceeded, the **service** symbol appears on the display. The coating procedure is not affected by this.

Trigger counter

The trigger counter (total time in days of trigger time) is shown in the display **A5**.

The trigger counter can't be reset!

View remaining service life

1. Press  key 2x
The display switches to the wearing part monitoring level

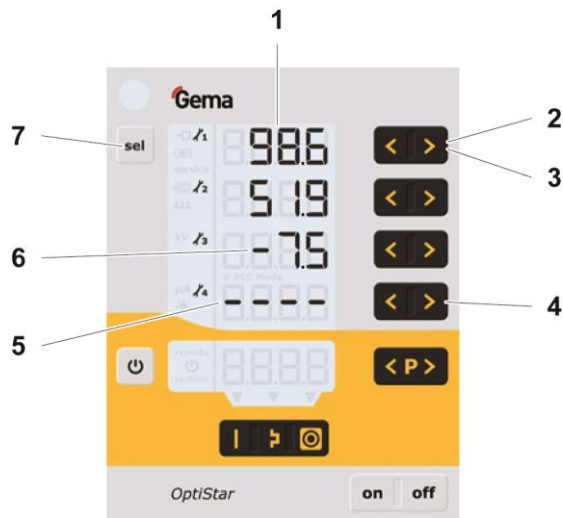

Designation	Function
1	Display of remaining service life: range 0.1 – 500 days
2	< or >: adjustment of service life
3	< and >: Deactivation of monitoring
4	< and >: Activation of monitoring
5	Monitoring deactivated
6	Service life expired negative value: display blinks
7	Exiting the wearing part monitoring display

Display example for wearing part no. 3	
Read minus days	-7.5 days
Selected service life	200 days
Operating life	207.5 days

Deactivation of wearing part monitoring



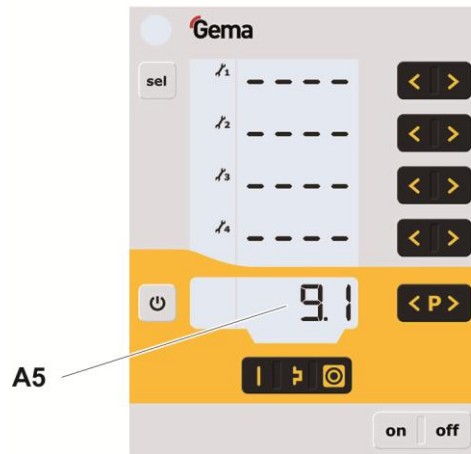

1. Press the  and  keys at the same time
Monitoring is deactivated.

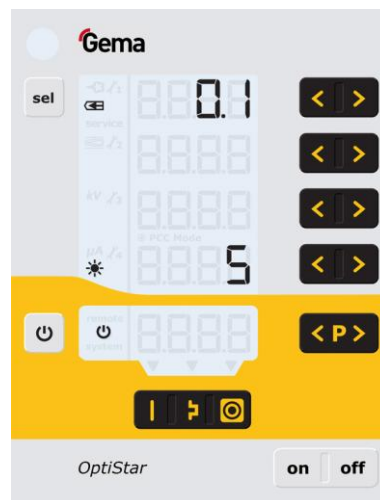

Setting the background illumination

1. Press the  key
The display switches to the following level:



2.    
Select the desired brightness

Checking the software version

1. Press these two keys at the same time



- The status display is shown as long as the keys are held.

RAM Reset

The RAM reset enables a restore of factory settings of the gun control unit. All parameters (**except P00**) and correction values as well as all user-defined values in the Program mode and Preset mode will be overwritten with factory default values. An active keyboard lock will be deactivated.



By resetting the RAM, all user-made settings will be set to factory default!

1. Switch off the device
2. Press the  key and hold it
3. Switch on the control unit, the **CLR** display blinks



4. Wait for approximately 5 seconds until **CLR** disappears
5. Release the  key
 - All values are reset. The control unit must be set-up again.

Decommissioning / Storage

Shutdown

1. End the coating procedure
2. Switch off the control unit



The adjustments for high voltage, powder output volume and electrode rinsing air remain stored.

When the product will not be used for several days

1. Switch off the power to the control unit at the main switch
2. Clean the gun and the components for powder conveying (see therefore the corresponding user manuals)
3. Turn off the compressed air main supply

Storage conditions

Hazard notes

There is no danger to personnel or the environment if the unit is stored properly.

Type of storage

The product must be stored horizontally for safety reasons.

Storage duration

If the physical conditions are maintained, the unit can be stored indefinitely.

Space requirements

The space requirements correspond to the size of the product.

There are no special requirements concerning distance to neighboring equipment.

Physical requirements

Storage must be inside a dry building at a temperature between +5 and +50 °C. Do not expose to direct sunlight!

Maintenance during storage

Maintenance schedule

No maintenance schedule is necessary.

Maintenance works

During long-term storage, periodically perform a visual check.

Maintenance / Repairs

General information

The product was designed for a maintenance-free operation.

Periodic checks

The periodic checks include examining all connecting cables and hoses.

The corresponding parts should be replaced immediately if any damage to cables or hoses is discovered.

All plugs must be properly tightened.

Repair work

In the event of malfunctions or faults, the product must be checked and repaired at an authorized Gema service location. The repairs must only be performed by an authorized specialist.

Improper interventions can result in serious danger for user or the equipment and may result in loss of warranty!

Troubleshooting

Error diagnosis of the software

General information

The correct function of the Gun control unit is constantly monitored. If the equipment software determines a fault, an error message is indicated with a help code. Following is monitored:

- High voltage technology
- Pneumatic system
- Power supply

Help codes

The error diagnosis codes (help codes) are shown in red on the **A5** display.



The help codes are stored in an error list in the order of their appearance. Each error in the list must be individually acknowledged with the keys **T10** or **T11**.

The errors are displayed in the order of their appearance. The **T10** and **T11** keys cannot be used for other functions, as long as an error code is still shown.

Here is a list of all possible help codes for this Gun control unit:

Code	Description	Criteria	Remedy
Pneumatics:			
H06	Trigger valve	Solenoid coil current lower than preset limiting value Valve defective, main board or cable defective	Contact a Gema service center

Code	Description	Criteria	Remedy
H07	Spraying air flow too high (Setting of spraying air on the display)	The preset value for spraying air is too high compared to the transport air setting	Lower spraying air value or increase value for transport air to equalize air volumes to the dense phase pump, delete error code
H08	Transport air volume too high (setting of powder share on the display)	The preset value for transport air is too high compared to the spraying air setting	Lower transport air value or increase value for spraying air to equalize air volumes to the dense phase pump, delete error code
H09	Powder output higher than 100%	The powder output multiplied by the powder hose length factor and daily correction value is greater than 100% Daily correction value too large	Reduce powder output Reduce daily correction value
H10	Transport air range lower deviation	The theoretical value for transport air falls below minimum Total air is smaller than minimum	Limit transport air to its minimum value
High voltage:			
H11	Gun error	No vibrations in the oscillator, cable break, oscillator or gun is defective	Contact a Gema service center
H13	Gun Overload	Cable or cascade defective. The control unit is switched off.	Contact a Gema service center
Power supply:			
H20	Voltage supply error Mainboard	Mainboard defective	Contact a Gema service center
H21	Supply undervoltage	Power pack defective or overloaded	Contact a Gema service center
H22	Wrong internal system clock	Backup battery is empty	Contact a Gema service center
EEPROM (equipment memory):			
H24	EEPROM content invalid	EEPROM error	Contact a Gema service center
H25	Timeout during EEPROM writing	EEPROM error	Contact a Gema service center
H26	Values not correctly stored in EEPROM during switching off	EEPROM error	Contact a Gema service center
H27	EEPROM verification erroneous	EEPROM error	Contact a Gema service center
CAN bus:			
H40	Permanent CAN bus error	The CAN controller changes into BUS OFF condition. No power supply or cable is not connected.	Connect the cable, otherwise contact Gema service

Code	Description	Criteria	Remedy
H41	High error rate when transmitting/receiving	The CAN controller changes into ERROR_PASSIVE condition	Contact a Gema service center
H42	Overflow on data reception	The message to be received has no more place in the receiver buffer. Messages are sent faster than they can be processed.	Contact a Gema service center
H43	Overflow on transmission	The message to be sent has no more place in the transmission buffer. Messages are produced faster than they can be sent.	Contact a Gema service center
H44	Master failed	Node Guarding message is missing longer than 2 seconds. Connection to master failed.	Check the connection to the Master, otherwise contact Gema service
H45	Parameter value outside the value range	The sent parameter value is outside the allowed value range	Check input values
H46	Invalid Node ID set	The Node ID is not between 1 and 127	Set Node ID to 127
H47	No CAN interface installed	CAN interface is selected in the system parameters, but no interface is installed	Contact a Gema service center
H48	No ACK to "Boot Up Message" received	No CAN node is answering to the "Boot Up Message".	Check cabling connections between the users, otherwise contact Gema service

Throttle motors:

H60	Transport air reference position not found	Throttle motor or needle jammed, limit switch defective, error in motor throttle	Contact a Gema service center
H61	Spraying air reference position not found	Throttle motor or needle jammed, limit switch defective, error in motor throttle	Contact a Gema service center
H62	Electrode rinsing air reference position not found	Throttle motor or needle jammed, limit switch defective, error in motor throttle	Contact a Gema service center
H64	Transport air throttle does not move	Short circuit in limit switch, motor throttle defective	Contact a Gema service center
H65	Spraying air throttle does not move	Short circuit in limit switch, motor throttle defective	Contact a Gema service center
H66	Electrode rinsing air throttle does not move	Short circuit in limit switch, motor throttle defective	Contact a Gema service center
H68	Transport air position lost	Lost steps, limit switch defective, throttle motor defective	Contact a Gema service center
H69	Spraying air position lost	Lost steps, limit switch defective, throttle motor defective	Contact a Gema service center
H70	Electrode rinsing air position lost	Lost steps, limit switch defective, throttle motor defective	Contact a Gema service center

Application pump:

H80 H180*	Pump not connected	The control unit is parameterized as pump control unit, but there is no pump connected.	Connect the pump
--------------	--------------------	-----------------------------------------------------------------------------------------	------------------

Code	Description	Criteria	Remedy
H82	$(GL_{soll} - TL) < 0$ (Total Air preset value – Transport Air) < 0	Total air is smaller than transport air which is resulting from powder output and daily correction value C2	Change the powder output correction value or daily correction value C2
H83	Application pump pressure control	Pressure falls below desired value longer than 5 s.	Check the compressed air supply, otherwise contact a Gema service center
H84	Application pump pressure measurement	A/D converter timeout. Possible cause: Hardware defective	Contact a Gema service center
H85	No Application pump interface	The unit is configured as pump control unit, but there is no pump interface	Check System parameter P0, otherwise contact a Gema service center
H86 H186*	Application pump pressure drop error	During the cleaning program first phase is the pressure still too high.	Cleaning program is interrupted Contact a Gema service center
H87 H187*	IN pinch valve leakage	Is displayed after IN pinch valve diagnostic. Pinch valve defective.	Replace the pinch valve or contact Gema Service
H88 H188*	OUT pinch valve leakage	Is displayed after OUT pinch valve diagnostic. Pinch valve defective.	Replace the pinch valve or contact Gema Service
H89	Pinch valve leakage / too high compressed air consumption	Pinch valve diagnostic during operation Pressure drop per each pinch valve closing higher then threshold value C9	Start the cleaning and then the pinch valve diagnostic If it occurs again, replace the pinch valve or contact Gema Service
Communication Mainboard-Gun:			
H91	Communication error mainboard-gun	Gun, gun cable or Mainboard defective	Replace or contact Gema Service

* Application pump no. 2

Help codes list

The last appeared four errors are stored in a list by the software. If an error appears, which is already in the list, he will not be listed again.

Appearance of errors

It is possible that a help code is only displayed for a short time, but after the acknowledgment it will disappear. In this case, it's recommended to switch off the device and switch it on again (reset by restarting).

Disposal

Introduction

Requirements on personnel carrying out the work

The disposal of the product is to be carried out by the owner or operator.

When disposing of components that are not manufactured by Gema, the instructions in the respective manufacturer's documentation must be observed.

Disposal regulations



The product must be disassembled and disposed of properly at the end of its service life.

- ▶ When disposing of the product, the applicable local and regional laws, directives and environmental regulations must be complied with!
-

Materials

The materials must be sorted according to material groups and taken to the appropriate collection points.

Disassembly of component groups

WARNING

Live components

Risk of fatal injury from electric shock if touched

- ▶ Only trained, authorized staff may open the electrical compartment
 - ▶ Observe the safety symbols
-

1. Disconnect the mains supply and supply cables.
2. Remove all product covers.

The product is now prepared for disassembly.

Spare parts list

Ordering spare parts

When ordering spare parts for your product, please indicate the following specifications:

- Type and serial number of your product
- Order number, quantity and description of each spare part

Example:

- **Type** Gun control unit OptiStar CG12-CP
Serial number 1234 5678
- **Order no.** 203 386, 1 piece, Clamp – Ø 18/15 mm

When ordering cable or hose material, the required length must also be given. The spare part numbers of this bulk stock is always marked with an *.

The wearing parts are always marked with a #. marked.

All dimensions of plastic hoses are specified with the external and internal diameter:

Example:

Ø 8/6 mm, 8 mm outside diameter (o/d) / 6 mm inside diameter (i/d)

⚠ WARNING

Use of non-original Gema spare parts

Use of Non-Gema replacement spare parts may invalidate some or all approval certificates and accreditations; and the user assumes all explosion risks associated with use of these parts. Use of these replacement spare parts may void any and all warranty claims.

- ▶ Use only original Gema spare parts!

OptiStar CG12-CP Gun control unit

	OptiStar CG12-CP Gun control unit – complete, without pos. 4	1009 301
1	Front plate – complete, see corresponding spare parts list	
2	Enclosure	
3	Backplate – complete, see corresponding spare parts list	
4	Cover	1008 301

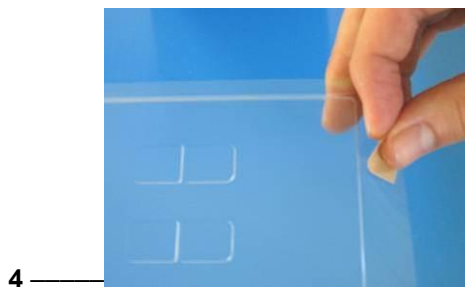

fig. 22

Front plate and power pack

	Front plate – complete (pos. 1-12)	1009 860
	Front plate with foil keyboard (pos. 5-8)	1009 859
1	OptiStar Mainboard – complete	1009 844
2	Spacer sleeve – Ø 3.1/6x15 mm	
3	PCB "Powerboard" – complete	1009 865
4	Spacer sleeve – Ø 3.2/6x7 mm	
5	Front frame – complete (incl. pos. 5.1)	1007 048
5.1	Screw	1007 019
6	Screw – M4x20 mm	1003 000
7	Front plate gasket	1007 042
8	Membrane keypad	
9	Spacer sleeve – Ø 3.6/7x5 mm	
10	Display	1007 044
11	Washer – Ø 3.2/7x0.5 mm	
12	Locknut – M3	
13	Power pack – 24 VDC	1009 849

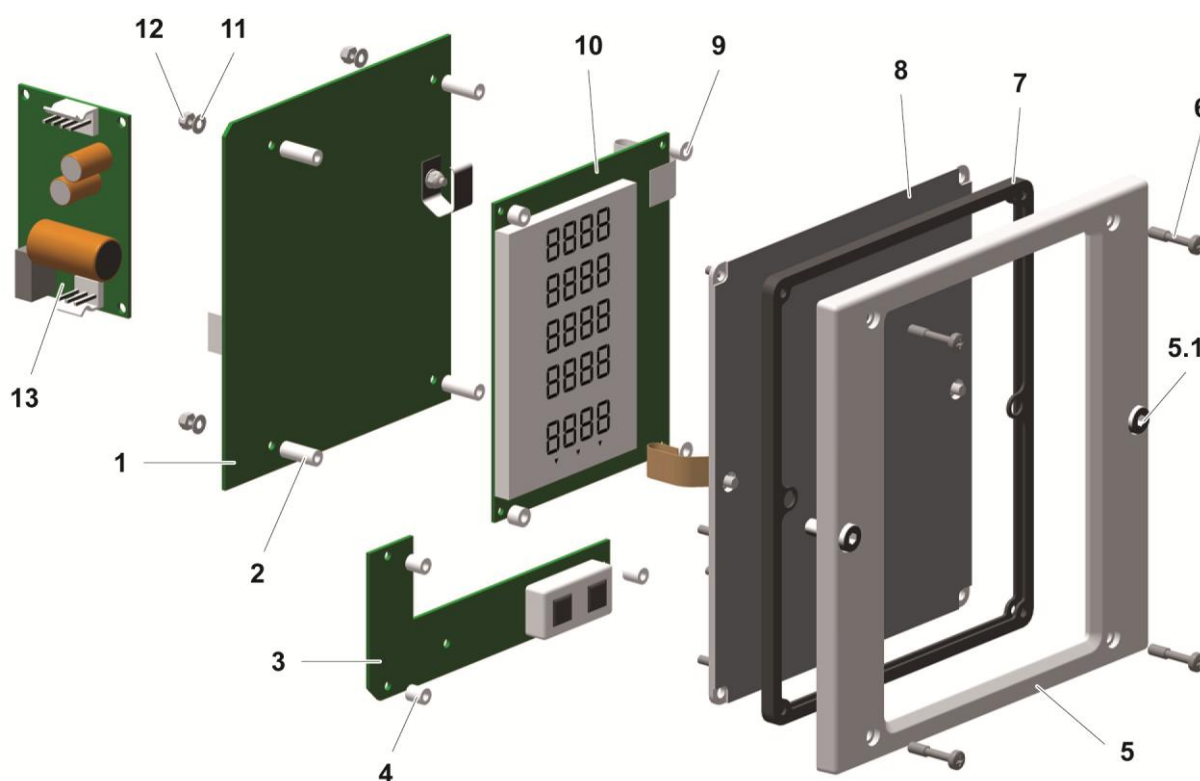

fig. 23

Inside back plate

1	Back plate gasket	1007 033
2	CAN bus module – complete	1015 234
3	Adjusting elbow – Ø 8-Ø 8 mm	1001 031
4	Solenoid valve – Ø 8-Ø 8 mm, 24 VDC	1003 914
5	Motor throttle – complete	1000 064
6	Plastic tube – Ø 8/6 mm	103 152*
7	Fluidizing pad – 1/8"	237 264
8	Cap screw – M4x16 mm	216 801
9	Solenoid valve	1009 936
10	T-piece – 1/8"- Ø 8- Ø 8 mm	246 573
11	Reducer – Ø 8- 6 mm	257 540
12	Block	1009 932
13	Elbow joint – 1/4"- Ø 8 mm	254 029
14	O-ring – Ø 12x1.5 mm, NBR70	261 416
15	Motor throttle – complete	1009 931
16	O-ring – Ø 8x4 mm, NBR70	1001 521
17	Intermediate piece	1009 938
18	O-ring – Ø 20x1.5 mm, NBR70	268 429
19	O-ring – Ø 13x1.5 mm, NBR70	1009 943
20	Connector	1009 939
21	Elbow joint – M5-Ø 6 mm	1009 941
22	AP01 interface – complete (incl. pressure sensors)	1012 552
23	Plastic tube – Ø 6/4 mm	103 144*

* Please indicate length

Inside back plate

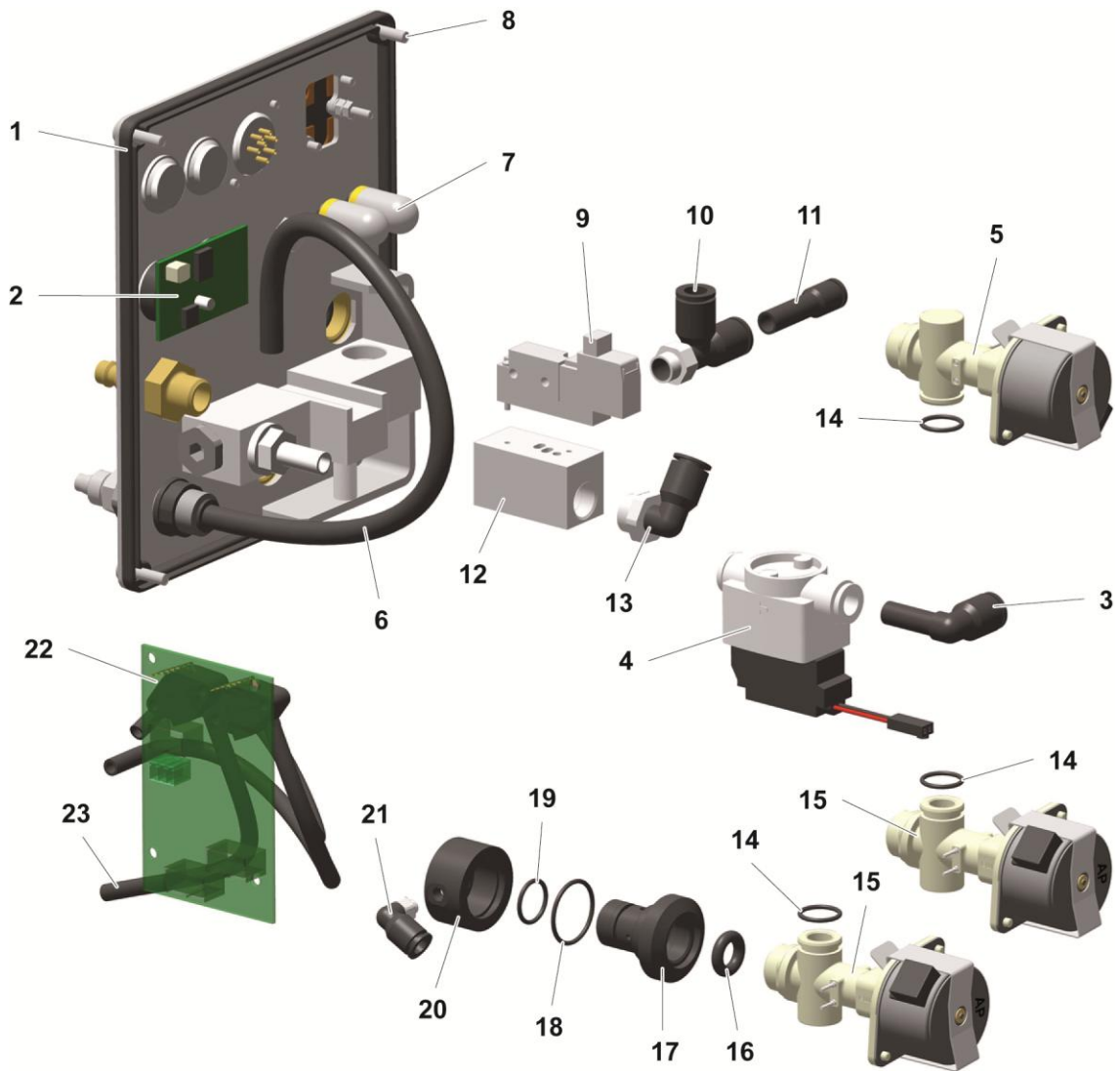

fig. 24

Connecting material

1	Quick release connection – NW5, Ø 6 mm	200 840
1.1	Hose – Ø 6/4 mm	103 144*
2	Nut with kink protection – M12x1 mm, Ø 8 mm	201 316
2.1	Spraying air hose – Ø 8/6 mm (black)	103 756*
2.2	Quick release coupling for spraying air hose – NW5-Ø 8 mm	261 637
3	Nut with kink protection – M12x1 mm, Ø 8 mm	201 316
3.1	Transport air hose – Ø 8/6 mm (blue)	103 497*
3.2	Quick release coupling for transport air hose – NW5-Ø 8 mm	261 645
4	Quick release connection – NW5-Ø 8 mm	203 181
4.1	Hose – Ø 8/6 mm	103 756*
5	Nut with kink protection – M12x1 mm, Ø 8 mm	201 316
5.1	Pinch valve air hose – Ø 8/6 mm (green)	103 519*
6	CAN bus cable – 0.5 m	1002 655
	CAN bus cable – 4.5 m	387 592
	CAN bus cable – 5.5 m	388 521
	CAN bus cable – 6.0 m	388 530
7	Bus terminal resistor (not shown)	387 606
8	Connecting cable – 12 pins, 1.5 m	1000 991
	Connecting cable – 12 pins, 2.2 m	393 398
	Connecting cable – 12 pins, 5 m	1000 975
	Connecting cable – 12 pins, 10 m	1000 976
	Connecting cable – 12 pins, 15 m	1000 977
	Connecting cable – 12 pins, 20 m	1000 978
9	Mains cable – 4.5 m	1002 563

* Please indicate length

Connecting material

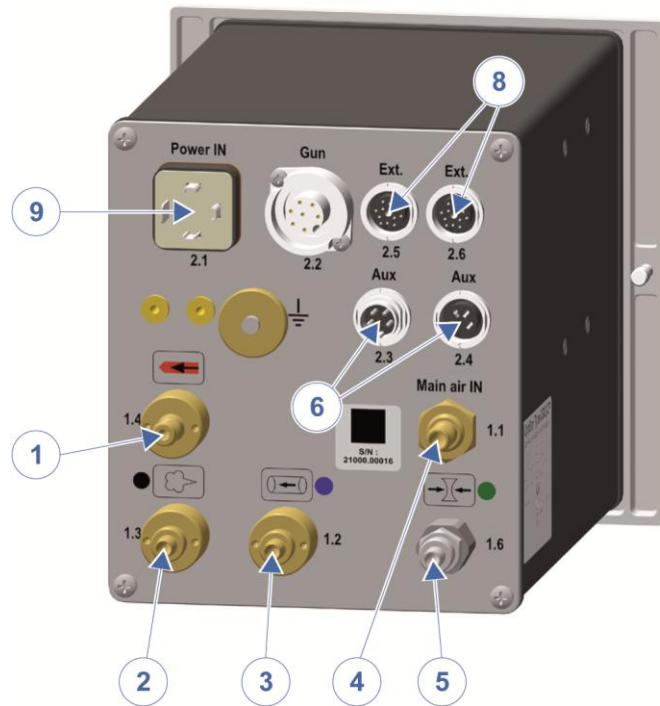

fig. 25

Index

A

About these instructions.....	7
Assembly.....	27

B

Basic safety instructions.....	11
--------------------------------	----

C

Connection.....	27
Connection instructions.....	28

D

Decommissioning.....	53
Disassembly of component groups.....	61
Disposal.....	61
Disposal regulations.....	61
Disuse for several days.....	53

F

Figure references in the text.....	8
------------------------------------	---

M

Maintenance.....	55
Maintenance during storage.....	54

O

Operating elements.....	18
Operation.....	39

P

Periodic checks.....	55
Pictograms.....	7
Presentation of the contents.....	8
Product description.....	13
Product specific security regulations.....	11

R

Repair work.....	55
Repairs.....	55

S

Safety.....	11
Safety symbols.....	7
Scope of delivery.....	23
Shutdown.....	53
Sound pressure level.....	16
Spare parts list.....	63
Start-up.....	31
Storage.....	53
Storage conditions.....	53

T

Troubleshooting.....	57
----------------------	----

