

---

Operating instructions and spare parts list

# OptiStar CG07-P Gun control unit

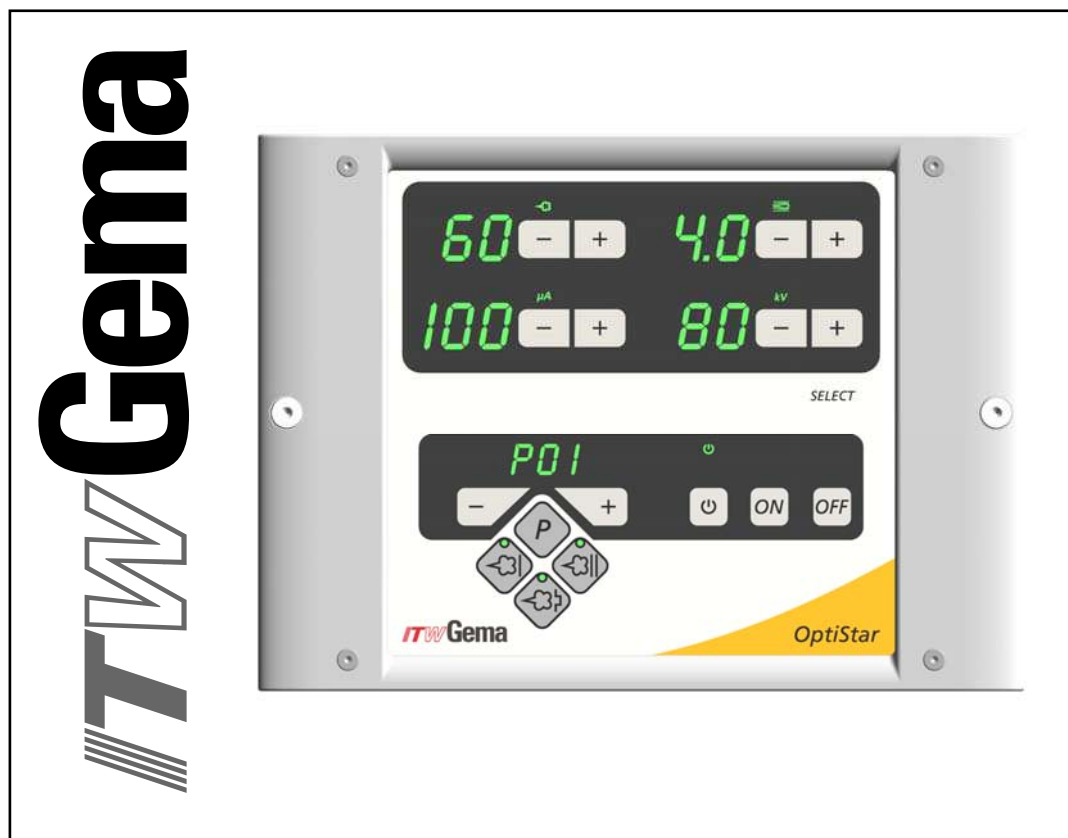

Translation of the original operating instructions

**Documentation OptiStar CG07-P Gun control unit**

© Copyright 2006 ITW Gema GmbH

All rights reserved.

This publication is protected by copyright. Unauthorized copying is prohibited by law. No part of this publication may be reproduced, photocopied, translated, stored on a retrieval system or transmitted in any form or by any means for any purpose, neither as a whole nor partially, without the express written consent of ITW Gema GmbH.

OptiFlex, OptiTronic, OptiGun, EasyTronic, EasySelect, OptiFlow and SuperCorona are registered trademarks of ITW Gema GmbH.

OptiStar, OptiSpray, OptiMatic, OptiMove, OptiMaster, OptiPlus, MultiTronic and Gematic are trademarks of ITW Gema GmbH.

All other product names are trademarks or registered trademarks of their respective holders.

Reference is made in this manual to different trademarks or registered trademarks. Such references do not mean that the manufacturers concerned approve of or are bound in any form by this manual. We have endeavored to retain the preferred spelling of the trademarks, and registered trademarks of the copyright holders.

To the best of our knowledge and belief, the information contained in this publication was correct and valid on the date of issue. ITW Gema GmbH makes no representations or warranties with respect to the contents or use of this publication, and reserves the right to revise this publication and make changes to its content without prior notice.

**Printed in Switzerland**

ITW Gema GmbH  
Mövenstrasse 17  
9015 St. Gallen  
Switzerland

Phone: +41-71-313 83 00  
Fax.: +41-71-313 83 83

E-Mail: [info@itwgema.ch](mailto:info@itwgema.ch)  
Homepage: [www.itwgema.ch](http://www.itwgema.ch)

# Table of contents

<b>General safety regulations</b>	<b>3</b>
Safety symbols (pictograms).....	3
Conformity of use.....	3
Product specific security measures .....	4
<b>About this manual</b>	<b>5</b>
General information .....	5
Software version .....	5
<b>Function description</b>	<b>7</b>
Field of application .....	7
OptiStar CG07-P Gun control unit .....	7
Typical characteristics.....	7
Basic functions.....	8
Additional functions.....	8
Functions - overview .....	8
Operating modes .....	9
Predefined operating mode (Preset mode).....	9
Adjustable operating mode (Program mode).....	9
<b>Technical data</b>	<b>11</b>
OptiStar CG07-P Gun control unit .....	11
General information .....	11
Connectable guns .....	11
Electrical data .....	12
Pneumatic data .....	12
Dimensions .....	12
Air flow rates .....	12
<b>Operating and display elements</b>	<b>13</b>
Display and LEDs .....	13
Input keys and switches.....	14
<b>Start-up and operation</b>	<b>15</b>
OptiStar CG07-P - connections .....	15
Connecting guide .....	16
OptiStar CG07-P pin assignment.....	17
Initial start-up.....	18
Setting the device type.....	18
Preparing the powder hopper/container .....	18
Switch on the booth .....	18
Daily start-up .....	19
Select operating mode .....	19
Setting powder output and powder cloud .....	20
Level 2 display .....	20

Setting the electrode rinsing air .....	21
Setting the fluidizing .....	21
Powder coating .....	22
Remote control by OptiSelect GM02 Manual gun .....	22
Shut-down .....	22
Saving programs .....	22
Technical explanations concerning high voltage and spray current.....	23
Characteristic curves of Preset mode .....	23
Characteristic curve of Program mode.....	23
Technical explanations about automatic transport air/spraying air setting .....	24
Transport air .....	24
Setting the spraying air.....	24
<b>Additional functions</b>	<b>25</b>
System parameter P0.....	25
Entering the system parameters .....	25
Exiting the system parameter mode .....	25
Trigger counter and software request .....	26
Keyboard lock.....	26
Powder output/powder hose correction.....	26
Carrying out a powder output correction .....	26
Procedure (powder output correction).....	27
Procedure (powder hose correction) .....	27
RAM reset.....	28
Cleaning mode .....	29
Cleaning programs .....	29
<b>Schematic diagrams</b>	<b>31</b>
OptiStar CG07-P - pneumatic diagram .....	31
OptiStar CG07-P - wiring diagram.....	32
<b>Troubleshooting</b>	<b>33</b>
Repairing the electrical part of the control unit .....	33
Replacing the fuse(s).....	33
Replacing the power supply board .....	33
Replace the front plate .....	34
Repairing the pneumatic part .....	35
Replacing the pneumatic part.....	35
Removing the pneumatic hoses .....	35
Fitting the pneumatic hoses.....	35
Error diagnosis of the software.....	35
General information .....	35
Error codes .....	36
Help codes list .....	37
Appearance of errors.....	37
<b>Spare parts list</b>	<b>39</b>
Ordering spare parts.....	39
OptiStar CG07-P Gun control unit - general.....	40
OptiStar CG07-P - inside rear wall .....	41
OptiStar CG07-P - outside rear wall.....	42
OptiStar CG07-P - enclosure and power pack.....	43
OptiStar CG07-P - front plate .....	44
Diffuser .....	45

# General safety regulations

This chapter sets out the fundamental safety regulations that must be followed by the user and third parties using the OptiStar CG07-P Gun control unit.

These safety regulations must be read and understood before the OptiStar CG07-P Gun control unit is used.

---

## Safety symbols (pictograms)

The following warnings with their meanings can be found in the ITW Gema operating instructions. The general safety precautions must also be followed as well as the regulations in the operating instructions.

**DANGER!**

Danger due to live electricity or moving parts. Possible consequences: Death or serious injury

**WARNING!**

Improper use of the equipment could damage the machine or cause it to malfunction. Possible consequences: minor injuries or damage to equipment

**INFORMATION!**

Useful tips and other information



---

## Conformity of use

1. The OptiStar CG07-P Gun control unit is built to the latest specification and conforms to the recognized technical safety regulations. It is designed for the normal application of powder coating.
2. Any other use is considered as non-conform. The manufacturer is not responsible for damage resulting from improper use of this equipment; the end-user alone is responsible. If the OptiStar CG07-P Gun control unit is to be used for other purposes or other substances outside of our guidelines, then ITW Gema GmbH should be consulted.
3. Observance of the operating, service and maintenance instructions specified by the manufacturer is also part of conformity of

use. The OptiStar CG07-P Gun control unit should only be used, maintained and started up by trained personnel, who are informed about and are familiar with the possible hazards involved.

4. Start-up (i.e. the execution of a particular operation) is forbidden until it has been established that the OptiStar CG07-P Gun control unit has been set up and wired according to the guidelines for machinery (98/37 EG). EN 60204-1 (machine safety) must also be observed.
5. Unauthorized modifications to OptiStar CG07-P Gun control unit exempts the manufacturer from any liability from resulting damage.
6. The relevant accident prevention regulations, as well as other generally recognized safety regulations, occupational health and structural regulations are to be observed.
7. Furthermore the country-specific safety regulations must be observed.

Explosion protection	Protection type	Temperature class
  II (2) 3 D	IP54	T6 (zone 21) T4 (zone 22)

## Product specific security measures

- The installation work, to be done by the customer, must be carried out according to local regulations
- Before starting up the plant a check must be made that no foreign objects are in the booth or in the ducting (input and exhaust air)
- It must be observed, that all components are grounded according to the local regulations, before start-up



**Note:**

**For further security information, see the more detailed ITW Gema safety regulations!**

# About this manual

---

## General information

This operating manual contains all the important information which you require for the working with the OptiStar CG07-P Gun control unit. It will safely guide you through the start-up process and give you references and tips for the optimal use of your new powder coating system.

Information about the function mode of the individual system components - booth, powder gun control unit, manual gun or dense phase pump - should be referenced to their corresponding documents.

---

## Software version

This document describes the operation of the OptiStar CG07-P Gun control unit, with software version starting from 1.10!



# Function description

---

## Field of application

The OptiStar CG07-P Gun control unit is designed exclusively for controlling the OptiSpray DPP01 Dense phase pump (see also in chapter "Technical data").

Any other use is considered as non-conform. The manufacturer is not responsible for any damage resulting from this - the risk for this is assumed by the user alone!

For a better understanding of the interrelationships in powder coating, it is recommended to read completely the operating instructions of the other components, so as to be familiar with their functions too!

---

## OptiStar CG07-P Gun control unit

### Typical characteristics

- The OptiStar CG07-P Gun control unit is used for the electrostatic powder coating with an OptiFlex manual equipment in addition to an OptiSpray DPP01 Dense phase pump
- The OptiStar CG07-P Gun control unit allows the configuration of process parameters (air and high voltage settings), system parameters, process data, status information and correction values. All air volumes can be controlled centrally by the unit
- The handling is simple and self-explanatory. The coating personnel can save individual settings, based off personnel experience, in 20 program places
- All settings for efficient powder coating are simple to operate and repeatable. The control unit electronics permit the exact amount of powder delivery and the adjusted values can be read on the digital displays
- The OptiStar CG07-P Gun control unit can be connected to mains voltages between 100-240 VAC, 50-60 Hz (single phase alternating current)

## **Basic functions**

- Intuitive operation
- Setting and display of the values on two levels
- Saving/recalling of process parameters in the form of programs
- Remote control feature on the manual powder gun (OptiSelect GM02 only)

## **Additional functions**

- Spray current regulation with high voltage limitation
- Control of the air volumes for the operation of the OptiSpray DPP01 Dense phase pump and the electrode rinsing air
- Status indications and error diagnosis

## **Functions - overview**

### ***Setting possibilities***

- Setting possibilities for powder output volume, total air, spray current, high voltage and electrode rinsing air
- Correction values for powder offset, powder hose correction value, daily correction and transport air offset

### ***Request values***

- Request values for software version and trigger hours counter

### ***Features***

- Keyboard lock, predefined mode (Preset Mode), 20 programs, error display and remote control on the manual powder gun (OptiSelect GM02)

---

## Operating modes

The OptiStar CG07-P Gun control unit can be operated with two operating modes. According to the selected application mode, spray voltage and spray current are automatically adjusted and limited.

### Predefined operating mode (Preset mode)

The OptiStar CG07-P Gun control unit provides three predefined application modes (flat parts, complicated parts and recoat parts already painted).

In this operating mode, current ( $\mu\text{A}$ ) and high voltage ( $\text{kV}$ ) are preset, powder and air volume can be set and saved for each application mode separately.

The remaining preset values are not changed by transition to the predefined operating mode and can be configured and saved furthermore.

### Adjustable operating mode (Program mode)

In this operating mode, 20 individually definable programs (**P01-P20**) are available. These programs are automatically saved and can be recalled again as the application requires.

The values for current, high voltage, powder output, total air and electrode rinsing air can be set as needed.



---

**Note:**

**The specified settings in the 20 programs and 3 application modes are saved automatically, without confirmation, after a two second delay and the display changes from preset values to actual values!**

---



# Technical data

---

## OptiStar CG07-P Gun control unit

### General information

The CG07-P Gun control unit controls the OptiSpray DPP01 Dense phase pump, which supplies the powder to the gun.

### Connectable guns

OptiStar CG07-P	connectable
OptiSelect GM02	yes, with diffuser
OptiGun GA02	yes, with diffuser and trigger adaptor
PG1	no
PG2-A	no
TriboJet	no







---

#### Attention:

The OptiStar CG07-P Gun control unit can only be used with the specified gun types!

---

## Electrical data

OptiStar CG07-P	
Nominal input voltage	100-240 VAC
Frequency	50-60 Hz
Input power	40 VA
Nominal output voltage (to the gun)	max. 12 V
Nominal output current (to the gun)	max. 1 A
Protection type	IP54
Temperature range	0 °C - +40 °C (+32 °F - +104 °F)
Max. operating temperature	85 °C (+185 °F)
Approvals	  II (2) 3 D PTB05 ATEX 5009
FM Approvals	

## Pneumatic data

OptiStar CG07-P	
Compressed air connection	Elbow connection, 8 mm
Input pressure (dynamic)	6.0 bar / 87 psi
Max. water vapor content of compressed air	1.3 g/m <sup>3</sup>
Max. oil vapor content of compressed air	0.1 mg/m <sup>3</sup>

## Dimensions

OptiStar CG07-P	
Width	248 mm
Depth	250 mm
Height	174 mm
Weight	approx. 5.2 kg

## Air flow rates

The input pressure of the OptiStar CG07-P Gun control unit has to be set dynamically (setting during powder coating) to 6.0 bar!

OptiStar CG07-P	
Electrode rinsing air flow rate	0-3 Nm <sup>3</sup> /h
Transport air flow rate	0-5 Nm <sup>3</sup> /h
Spraying air flow rate	0-5 Nm <sup>3</sup> /h
Fluidizing air flow rate (OptiFlex FP)	0-5 Nm <sup>3</sup> /h

# Operating and display elements

## Display and LEDs

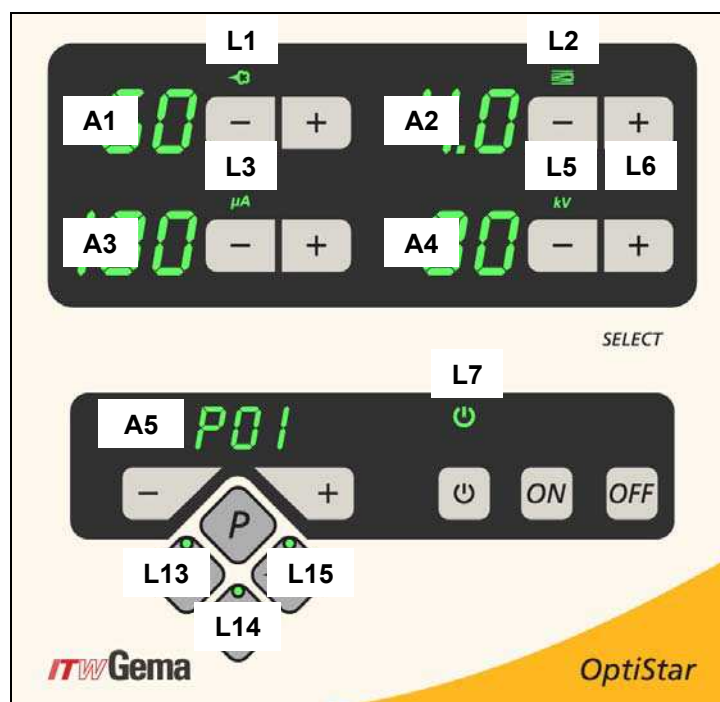

OptiStar CG07-P Gun control unit - display and LEDs

Designation	Function
A1-A4	Display of actual values, preset values and system parameters
A5	Display of program numbers, error diagnosis codes and status information
A1 (level 2)	Transport air (display in Nm <sup>3</sup> /h)
A2 (level 2)	Spraying air (display in Nm <sup>3</sup> /h)
L1	Powder output (display in %)
L2	Total air volume (display in Nm <sup>3</sup> /h)
L3	Spraying current (display in μA)
L5	High voltage (display in kV)
L6	Electrode rinsing air (display in Nm <sup>3</sup> /h)

Designation	Function
L7	Activation of fluidization
L13	Application mode for flat parts is activated
L14	Application mode for complicated parts is activated
L15	Application mode for recoating parts already coated is activated

## Input keys and switches

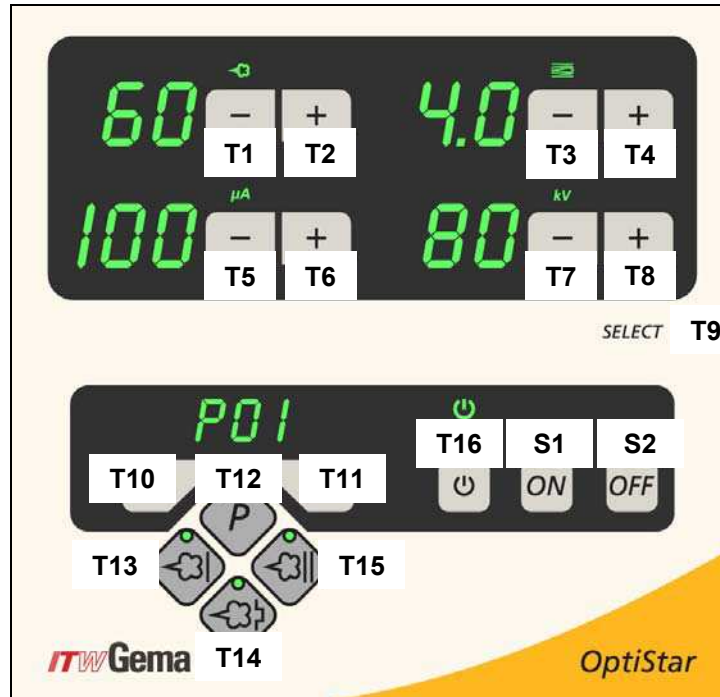

OptiStar CG07-P Gun control unit - input keys and switches



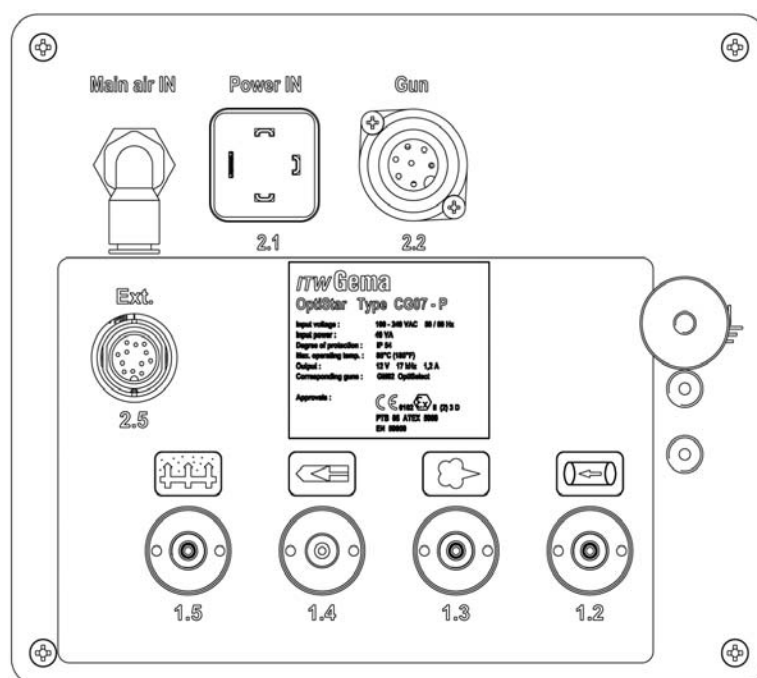

Designation	Function
T1-T8	Input keys for preset values and system parameters
T9 (Select)	Switch between display levels
T10-T11	Program change
T12 (P)	Program selection for user-defined programs (max. 20)
T13	Application mode for flat parts (fix values)
T14	Application mode for complicated parts with depressions (fixed values)
T15	Application mode for overcoating parts already coated (fixed values)
T16	Switching on and off the fluidization Switch to system parameter mode (press for at least 5 secs)
S1/S2	Power switch ON/OFF

# Start-up and operation

## OptiStar CG07-P - connections



OptiStar CG07-P Gun control unit - connections on the rear side

Connection	Description
1.1 Main air IN	Compressed air connection
2.1 Power IN	Mains cable connection (100-240 VAC)
2.2 Gun	Gun cable connection
2.5 Ext.	DPP01 Dense phase pump connection
1.5	Fluidizing air connection 
1.4	Electrode rinsing air connection 
1.3	Spraying air connection 
1.2	Transport air connection 
	Grounding connection 

## Connecting guide

1. Connect the compressed air supply from the compressed air circuit to the **Main air IN** connection (elbow connection, 8 mm) on the rear side of the control unit





---

**Note:**

**The compressed air must be free from oil and water!**

---

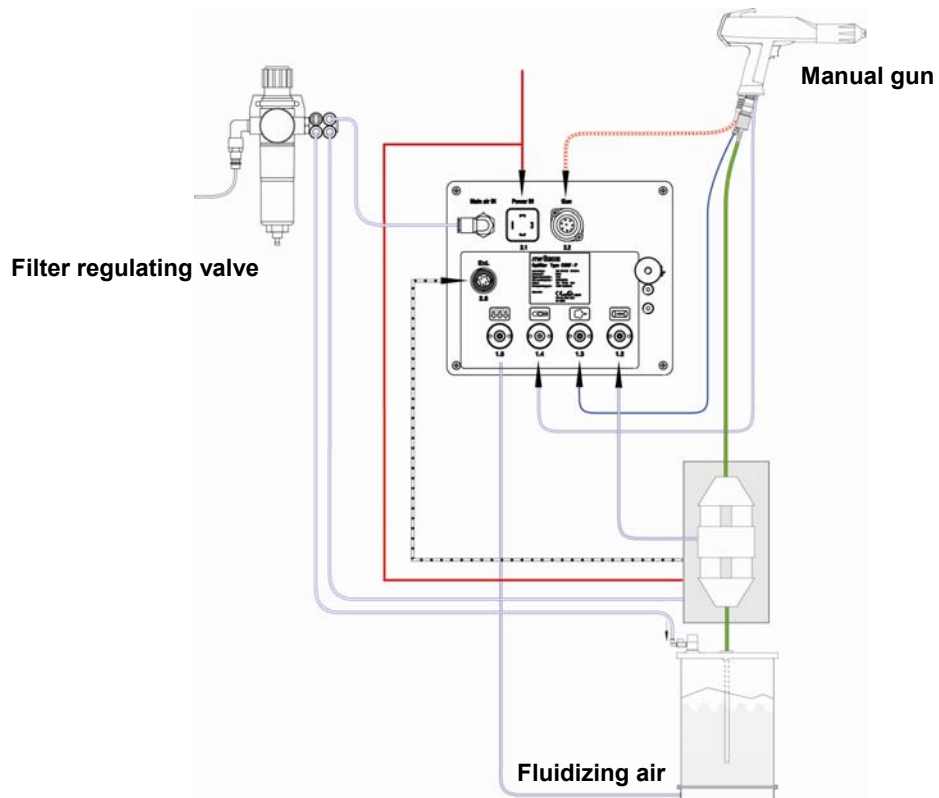
2. Connect the grounding cable to the control unit with the grounding screw, and the 5 m long grounding cable with the clamping clip to the booth or the conveyor. Check ground connections with Ohm meter and ensure 1 MOhm or less
3. Connect the black hose for fluidizing air (electrically conductive) to the output **1.5** on the rear side of the control unit
4. Connect the gun cable plug to the socket **2.2** on the rear side of the control unit
5. Connect the rinsing air hose to the electrode rinsing air output **1.4** and to the powder gun
6. Connect the gun to the outgoing powder hose of the OptiSpray DPP01 Dense phase pump
7. Connect the spraying air hose to the output **1.3** on the rear side of the control unit and to the diffuser on the powder gun
8. Connect the transport air hose to the output **1.2** on the rear side of the control unit and to the OptiSpray DPP01 Dense phase pump
9. Connect the mains cable to the **2.1 Power IN** plug and fasten it



Connection with manual gun

## OptiStar CG07-P pin assignment

### Power IN

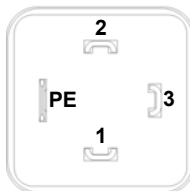

### Power IN connection

- 1 Neutral conductor (power supply)
- 2 Phase (100-240 VAC)
- 3 empty
- PE Ground PE

### Gun

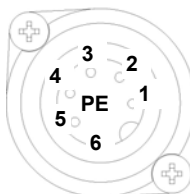

### Gun connection

- 1 Ground
- 2 Remote control 1 (GM02)
- 3 Ground
- 4 Trigger
- 5 Remote control 2 (GM02)
- 6 Oscillator
- PE Ground PE

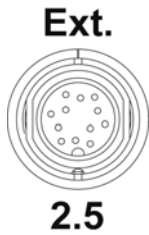

**Dense phase pump connection**

- A-J Control signal valve 1-9
- K IDENT / Recognition
- L REQUEST / Request
- M GND / Ground
- Enclosure Shield

**Initial start-up**

**Setting the device type**

Adjust the corresponding device type (fluidizing) by pressing the **T16** key (see chapter "System parameter P0" for more details).



**Note:**

**If the control unit is supplied as a component of a complete Opti-Flex unit, the corresponding system parameter is set correctly by the factory!**

**System parameter P0=0**

**Fluidizing air behavior**

Device type	Fluidizing air function
Fluidizing device (OptiFlex F)	Fluidizing air is controlled by two different methods: Turning on the fluidization key <b>T16</b> will feed air to the hopper until key is turned off Triggering the gun is turning on the fluidization too, fluidization can be turned off with key <b>T16</b>



**Note:**

**After changing the device type from P0=3 to P0=0 (fluidizing device), a RAM reset must be done!**

**Preparing the powder hopper/container**

Prepare the powder hopper (reference the corresponding operating manual).

**Switch on the booth**

Switch on the powder coating booth according to its operating manual.

## Daily start-up

The daily start-up of the OptiStar CG07-P Gun control unit takes place by the following steps:

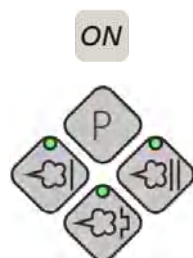

### Select operating mode

Select the predefined application mode (Preset mode) or the adjustable application mode (Program mode).

1. Turn on the gun control unit with the **ON** key
2. Select the corresponding application mode with the key **T12** (for Program mode) or the application keys **T13/T14/T15** (for Preset mode)

### Starting the predefined operating mode (Preset mode)

Select the Preset mode with the keys **T13/T14/T15**. The LED of the corresponding application key illuminates. No program number will be shown on the display **A5**. The values for powder output and total air volume, indicated before the changeover, are maintained.



### Application mode for flat parts

This application mode is suitable for the coating of simple, flat workpieces without larger cavities.



### Application mode for complicated parts

This application mode is suitable for the coating of three-dimensional workpieces with complicated shapes (e.g. profiles).



### Application mode for recoating parts already coated

This application mode is suitable for the overcoating of workpieces which are already coated.



The three application modes have predefined values for high voltage and spray current:

Presetting	Desired $\mu\text{A}$	Desired kV
Flat parts	100	100
Complicated parts	22	100
Overcoating	10	100

### Exiting the Preset mode



Exit the Preset mode with the keys **T10**, **T11** or **T12**. The preset values of the Program mode used before the Preset mode are displayed by the control unit memory.

### Starting the adjustable operating mode (Program mode)



Select this application mode with the program key **T12**. Here, 20 individually adjustable programs can be defined and saved. The programs 1-20 are loaded with preset values by factory. Factory preset values are 60% powder output at 4.0 Nm<sup>3</sup>/h total air and 20 µA spray current at 80 kV high voltage.

### Setting powder output and powder cloud

The powder output depends on the selected powder output and the adjusted total air volume.

#### Setting the total air volume



Adjust the total air volume with the keys **T3/T4** (see therefore the OptiSpray DPP01 Dense phase pump operating manual). The factory default value is set on 4.0 Nm<sup>3</sup>/h.

#### Setting the powder output

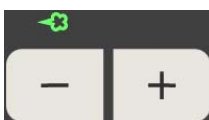

Adjust the powder output volume according to the desired coating thickness. The selection takes place with the keys **T1/T2** on the control unit or with the +/- keys on the rear side of the powder gun (OptiSelect gun type). The factory default setting is 60%.



Check the powder fluidization (see therefore chapter "Setting the fluidizing").



**Note:**

**The transport air and the spraying air setting takes place automatically by the device, based on the adjusted powder output volume, the total air volume and the correction factor settings!**

### Level 2 display



Level 2 display



The level 2 display is show by pressing the **Select** key. In the lower two display areas, the values for fluidizing air and electrode rinsing air

can be adjusted. In the upper two display areas, the calculated values for transport air and spraying air are displayed.

For details, see chapter "Technical explanations about automatic transport air/spraying air setting". If no key is pressed for 6 seconds, the display switches back to level 1.

## Setting the electrode rinsing air

Adjust the correct electrode rinsing air according to the applied nozzles (deflector plate, flat jet nozzle)



1. Press the key **T9 (SELECT)**  
The second display level will be shown
2. Press the keys **T7/T8**  
Here, the corresponding air volume value is entered
3. If this display level is not operated for 6 seconds, the first display level will be switched over independently

## Setting the fluidizing

The powder fluidizing depends on the powder type, the air humidity and the ambient temperature.

### Procedure:

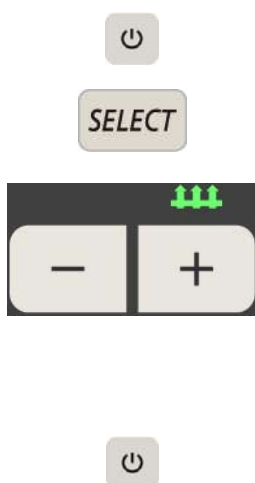

1. Adjust the air mover by turning the ball valve fully open and adjusting the throttle valve as required
2. Open the powder hopper cover
3. Switch on the fluidizing air with the key **T16**
4. Press key **T9 (SELECT)**  
The second display level will be switched over
5. Adjust the fluidizing air with the keys **T5/T6**
  - If the adjustment keys (+ or -) are not operated for 6 seconds, the display will switch to the first display level
  - The powder should "boil" lightly and regularly, if necessary, mix the powder with a stick
6. Close the cover
7. The fluidization can be switched off with the key **T16**, if required. By pressing the gun trigger, the fluidization switches on automatically

## Powder coating



**Attention:**

**Make sure first, that all electrically conductive parts within 5 m of the coating booth are grounded!**



1. Point the gun into the coating booth, but do not direct it to the object to be coated
2. Select the operating mode:  
Select the operating mode with program key **T12** or the application keys **T13/T14/T15**. The LED of the corresponding application key illuminates
3. Press the powder gun trigger
4. Coat the objects

## Remote control by OptiSelect GM02 Manual gun



Various functions can be remotely controlled with the **+** and **-** keys on the rear side of the powder gun (OptiSelect GM02 type):



- Modify the powder output (press the **+** or **-** key on the gun). The powder output will be increased or decreased accordingly
- Change the application modes (Preset mode/Program mode) by pressing the **+** and **-** keys on the gun at the same time. The change takes place counterclockwise. Check by observing the key LEDs on the control unit



**Note:**

**By pressing one of the keys, the preset values will be shown for 3 seconds!**

## Shut-down

The shut-down of the OptiStar CG07-P Gun control unit takes place in following steps:



1. Loosen the gun trigger
2. Switch off the control unit with the key **S2**
3. Switch off the Airmover

## Saving programs



**Note:**

**The values in the programs 1-20 and the 3 preset application modes are saved automatically, without confirmation!**

# Technical explanations concerning high voltage and spray current

## Characteristic curves of Preset mode

The preset values for high voltage and spray current in the predefined operation mode (Preset mode) are to be taken as reference points. The modification of these values has effects on the characteristic curve of the gun (see diagram). The operator can optimize the application within the possible three ranges.

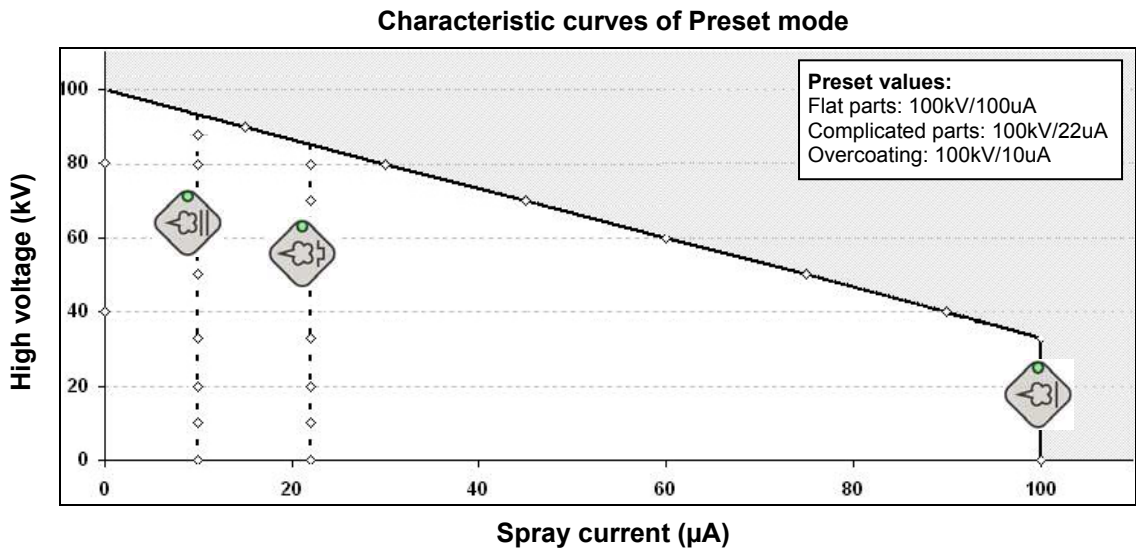

## Characteristic curve of Program mode

In the user-defined operating mode (Program mode), the values for high voltage and spray current are adjustable. The operator can optimize the values for his application by utilizing the ranges below (see diagram).

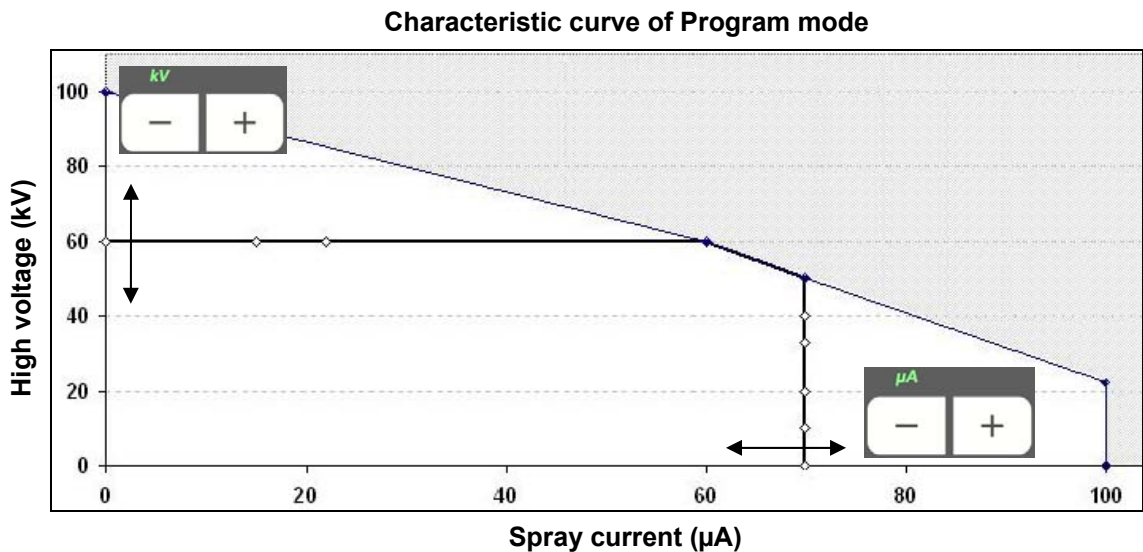

# Technical explanations about automatic transport air/spraying air setting

## Transport air

The transport air will be used for conveying the powder from the dense phase pump to the powder gun. The transport air quantity will be set automatically by the device, based on the adjusted powder quantity and an adjustable correction factor (transport air offset **C3**).

The transport air calculation depends furthermore on the correction factors **C1** and **C2**, which are also considered.

### Transport air (TL) calculation

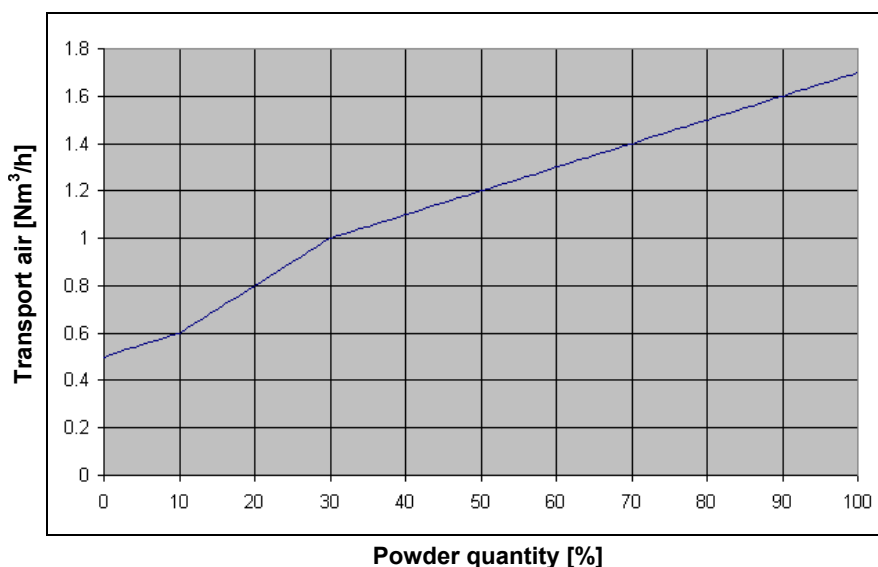

*Characteristic curve of the transport air*

## Setting the spraying air

The spraying air (**ZL**) will be defined in accordance to the calculated transport air (**TL**) and the adjusted total air volume (**GL**).

**Formula:**

$$GL = ZL + TL$$

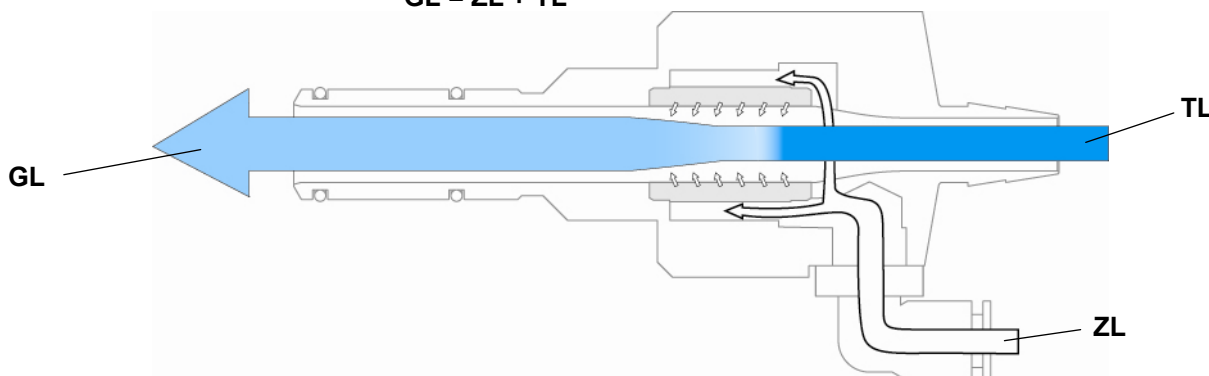

*Air streams in the diffuser*

# Additional functions

## System parameter P0

The OptiStar CG07-P Gun control unit is configured with the system parameter **P0**. The configuration will be saved in the control unit memory.

The system parameters are shown on the display **A5** with additional alphanumeric abbreviated designations (for function and condition).

### Entering the system parameters



1. To enter the system parameter mode, press the key **T16** longer than 5 seconds
2. The system parameter number is shown in the display **A1** with a **P** placed in front
3. Adjust the corresponding system parameter value (device type) with the keys **T5/T6**.  
The value of the adjusted system parameter appears on display **A3**
4. The system parameter **P0** must be set to **F** (fluidizing device)

Name	Description	Values	Display
P0	Device type	<b>0 - Fluidizing device (type F)</b> 1 - Box device (vibrator) (type B) 2 - Agitator device (type S) <b>3 - Automatic device</b> 4 - Manual device with fluidization	<b>F</b> B S <b>A</b> S Fd

Default values are marked by **bold** print



#### Note:

**After modifying the system parameter P0, a RAM reset must be done, so that the default values are corrected!**

### Exiting the system parameter mode



Exit the system parameter mode with the key **T16**, and the actual values display will appear. The modified values will be saved in the equipment memory.

## Trigger counter and software request

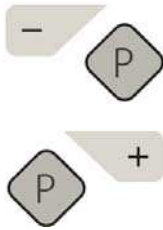

The status information can be indicated on display **A5** by pressing a combination of two different keys as shown. First press and hold key **T12**, then press either key **T10** or **T11** depending on requested information.

Status information	Key combination
Trigger ten-hours counter (total time in ten hours of gun trigger time). Trigger counter can not be reset!	<b>T12 with T10</b>
Software version	<b>T12 with T11</b>

The status display is shown as long as a key is held.

## Keyboard lock

The OptiStar CG07-P Gun control unit contains a keyboard lock, which prevents changing individual values for each parameter (kV,  $\mu$ A etc.) within an application mode (Preset or Program). The following is not affected by the keyboard lock and will still operate under normal conditions:

- Program selection
- Display of preset values of the current program
- Displaying the actual values
- Error acknowledgement
- The keyboard lock is activated and deactivated by pressing and holding key **T9 (SELECT)** and then key **T11**, the LED **L11 (REMOTE)** flashes. The keyboard lock status remains stored, when switching the equipment off and on. If a memory reset takes place, the keyboard lock will be deactivated



## Powder output/powder hose correction

The OptiStar CG07-P Gun control unit can be adapted with the correction values optimally to local conditions (e.g. the adaption of different powder outputs in the plant).

### Carrying out a powder output correction

Powder output corrections are made at the first start-up, after a service work, after the solution of application problems, or by using different hose diameters!

It is recommended to create a table with input fields for each gun (see chapter "Example table for powder output/powder hose correction"), so that, if a possible system reset takes place, an access to these data can take place.

The guide values can be extract from the following table:

Corr.-value	Description	Range	Default value
C0	Powder offset (ms)	0-50	20
C1	Powder hose correction value (%)	40-100	100
C2	Daily correction value (%)	50-150	100
C3	Transport air offset (Nm <sup>3</sup> /h)	0-2.0	0.5

## Procedure (powder output correction)

1. Set the total air to **4.0** (Nm<sup>3</sup>/h) on the **A2** display. Set the powder output to **00** (%) on the **A1** display
2. To enter the system parameter mode, press the key **T16** longer than 5 seconds. The correction factor number is shown in the display **A2** with a **C** placed in front
3. Set the correction value for minimum powder output **C0** to **20** (ms) on the **A4** display with the keys **T7/T8**
4. Set the correction value for maximum powder output **C1** to **100** (%) on the **A4** display



For the next steps a measuring bag is necessary, for weighing the powder output. If possible, one bag should be used for each gun. Do not forget to note the dead weight of each individual measuring bag.

5. Put the measuring bag over the gun nozzle and fasten it. Switch on the gun for 60 seconds
6. After this time has elapsed, switch off the gun, remove the measuring bag and weigh it. The powder output should be between 10-15 gr.
7. If no powder is expelled from the gun, return to the system parameter mode and increase the minimum powder output value **C0** (range **0-50** ms)
8. Repeat steps 5 and 6, until the powder output amounts to 10-15 g. Annotate the adjusted minimum powder output value **C0** in the table



Exit the system parameter mode by pressing the key **T16**.

## Procedure (powder hose correction)

The powder hose correction is only needed if several guns must have the same powder output amount.

1. Set the powder output value to **80** (%) on the **A1** display
2. Put the measuring bag over the gun nozzle and fasten it. Switch on the gun for 60 seconds
3. Switch off the gun after 60 seconds, remove the measuring bag and weigh it
4. Annotate the powder output in **g/min** in the table

Calculate the powder output correction according to following formula:

$$C1 (\%) = \frac{\text{smallest powder output}}{\text{measured powder output}} \times 100$$

5. Annotate the calculated values (**C1**) for each individual gun in the table and enter the values to the control unit (therefore, repeat the steps 2 and 3)



**Note:**  
The daily correction value (**C2**) can be used to allow high powder volumes!



**Note:**  
The hose length correction factor (**C1**) is chosen in such a way, that no powder is visible if the powder output quantity is 0%, by increasing the value, the powder becomes visible. This performance depends on the hose length and the hose diameter!



**Note:**  
The transport air offset (**C3**) can be used to correct the powder output if it is spitting or inconsistent!

## RAM reset

The RAM reset enables a restore of factory settings of the OptiStar CG07-P Gun control unit. All user-defined values in Program and Preset mode will be set to factory default. The adjusted device type in system parameter **P0** remains stored thereby, and an active keyboard lock will be deactivated.



Execute the RAM reset by pressing the key **T16** and the **ON** switch for 5 seconds.



**Note:**  
By resetting the RAM, all user-made settings will be set to factory default!



**Note:**  
After modifying the system parameter **P0**, a RAM reset must be done!

## Cleaning mode

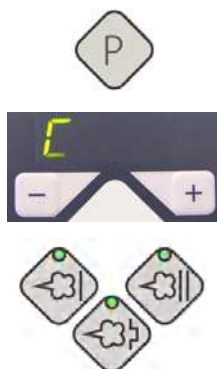

The cleaning mode enables the cleaning of the dense phase pump and the powder hose. Three different rinsing programs are available to prepare the dense phase pump for a color change.

Activate the cleaning mode by pressing the program key **T12** for 5 secs. The activated cleaning mode is indicated by a circulating luminous segment in the display **A5**. The individual cleaning programs are selected with the keys **T13**, **T14** and **T15**, thereby, the LED of the corresponding program blinks. The cleaning program will be started by activating the gun trigger (OptiStar CG07-P) or by activation of the powder gun (OptiStar CG06-CP).

### Cleaning programs

#### *Powder chamber emptying*



In this cleaning program (key **T13**), some air is blown through the filter elements in the powder chambers. The cleaning process can be additionally supported by blowing compressed air into the suction hose.



---

**Note:**

**The dense phase pump may be cleaned with a pressure of max. 4 bar!**

---

#### *Cleaning the hose to the gun*



In this cleaning program (key **T14**), the powder hose to the gun will be cleaned with 8 long and 18 short air blasts for each powder chamber. During this time, the pinch valves on the suction side remain closed.

#### *Cleaning the hose on the suction side*



In this cleaning program (key **T15**), the powder hose on the inlet of the dense phase pump will be cleaned with 8 long and 18 short air blasts for each powder chamber. During this time, the pinch valves on the output to the gun remain closed.



---

**Attention:**

**Large dust formation possible!**

**The powder hose and the powder gun must be pointed into the booth during the cleaning procedure!**

---



The cleaning mode is terminated by pressing the program key **T12**.



# Schematic diagrams

## OptiStar CG07-P - pneumatic diagram

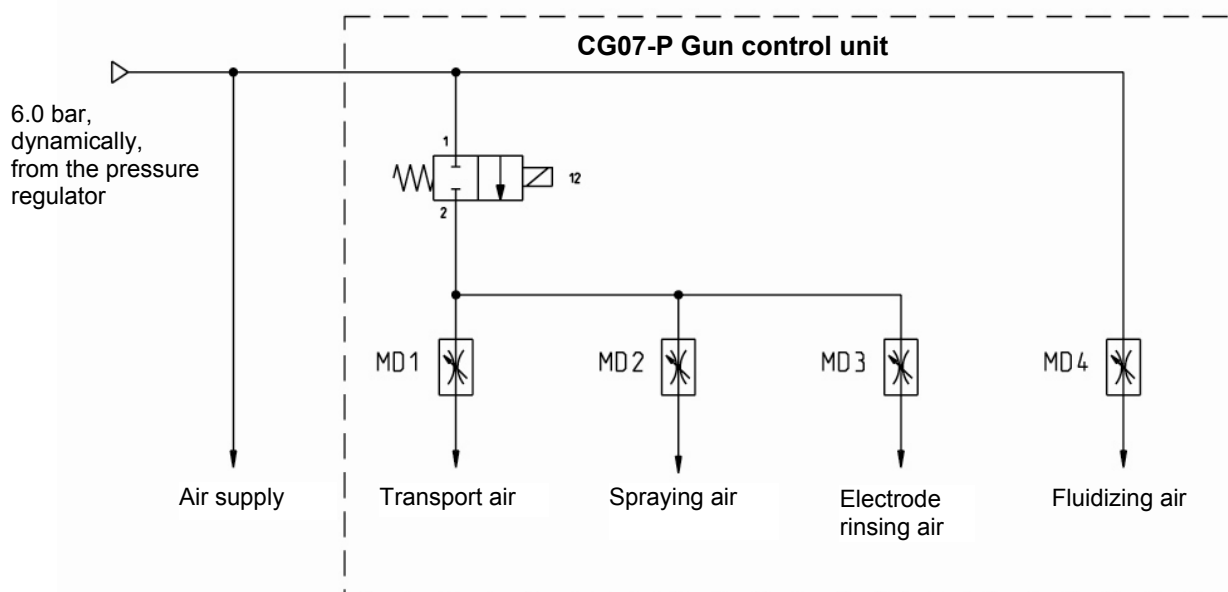

OptiStar CG07-P - pneumatic diagram

# OptiStar CG07-P - wiring diagram

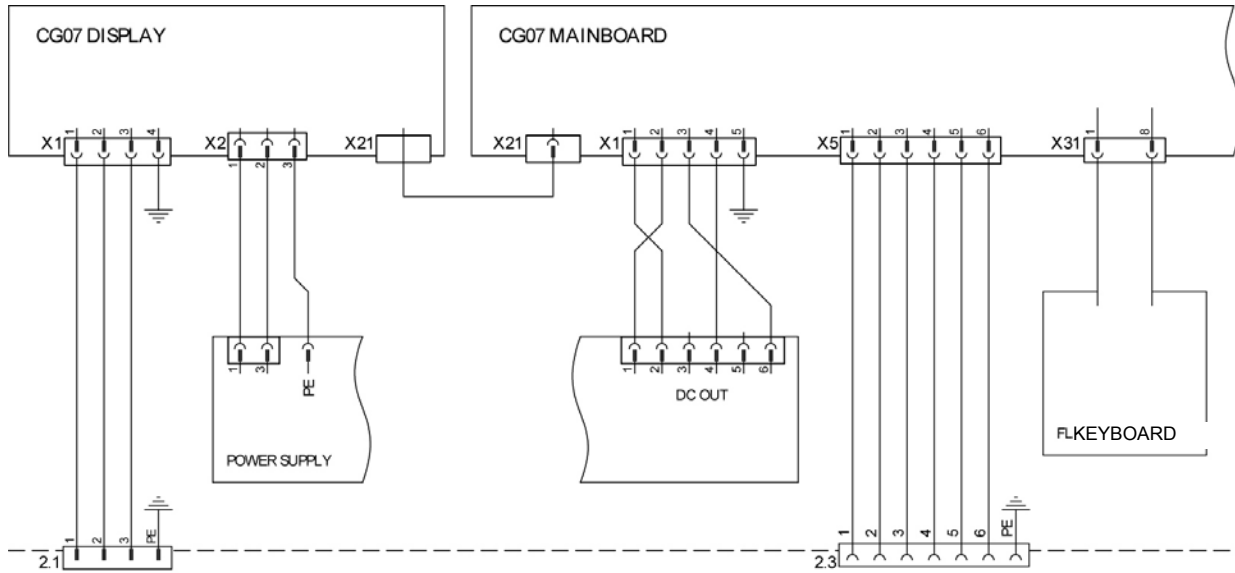

OptiStar CG07-P - wiring diagram, part 1

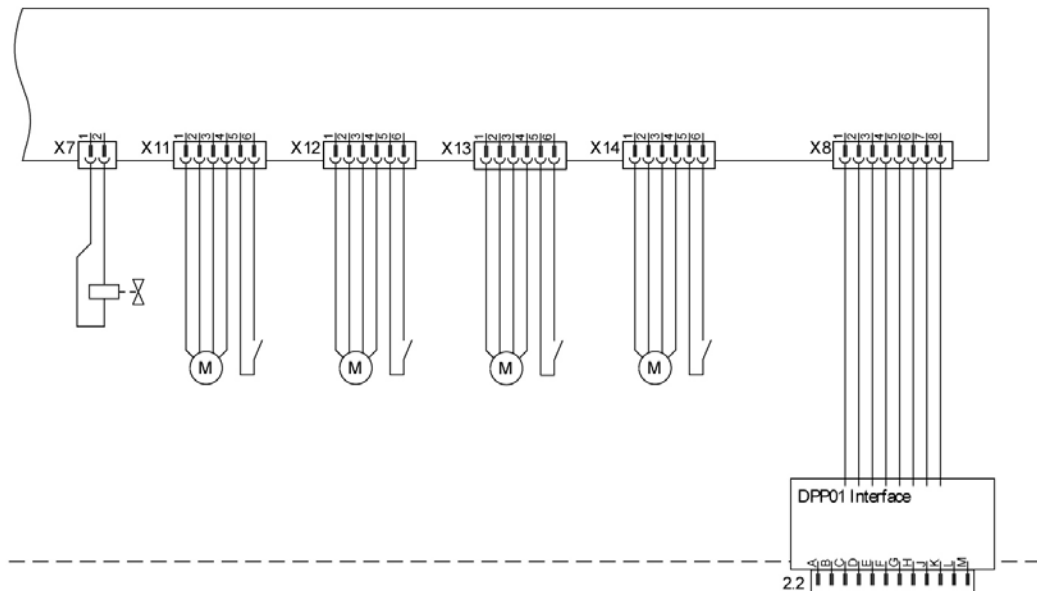

OptiStar CG07-P - wiring diagram, part 2

# Troubleshooting

---

## Repairing the electrical part of the control unit

---



**Attention, danger!**  
**Before starting the work on the control unit, disconnect the mains plug!**

---

### Replacing the fuse(s)

1. Loosen the screws on the front side of the enclosure
2. Hold the front plate with one hand, remove the fuse(s) from the fuse holder and replace with a new one

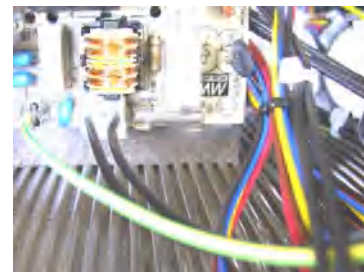

*Fuse(s)*

3. Reattach the front plate
4. Reconnect the mains cable

### Replacing the power supply board

1. Loosen the screws on the front side of the enclosure
2. Disconnect the plugs on the defective board
3. Squeeze the standoffs with a pointed pliers and remove the power supply board. Replace the defective standoffs
4. Place the new board on the standoffs, press them into the board and snap into mounting bracket within enclosure. Reconnect the plugs
5. Reassemble the control unit in reverse order as described and install it

6. Reconnect the mains cable

### Replace the front plate

1. Loosen the screws on the front side of the enclosure
2. Disconnect all plugs from the front plate
3. Replace the front plate
4. Reassemble the front plate and the control unit in reverse order as described and install it



**Attention:**  
The motor plugs are to be put in according to the annotation!

5. Reconnect the mains cable



**Note:**  
If there are any problems or uncertainties, please contact a ITW Gema service center!

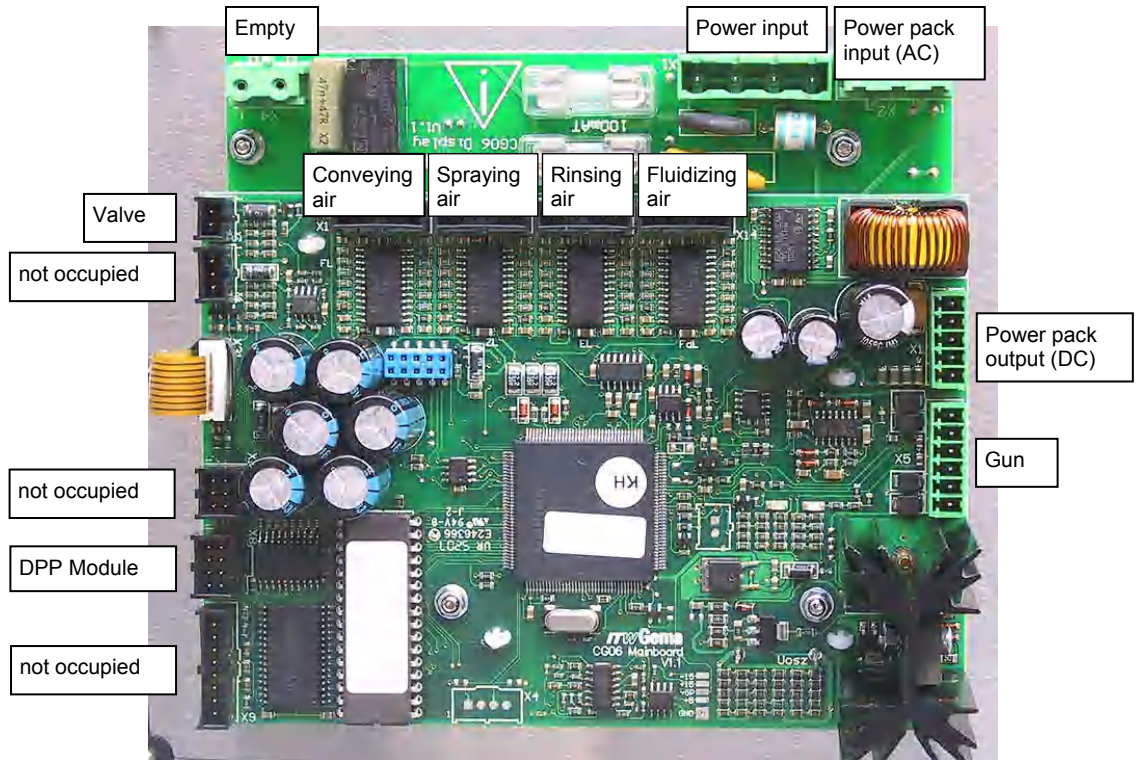

*OptiStar CG07-P - configuration*

---

## Repairing the pneumatic part

### Replacing the pneumatic part

1. Remove every electric and pneumatic connection on the rear side of the control unit (disconnect mains cable and remove compressed air supply)
2. Loosen the screws on the rear side of the enclosure
3. Remove the pneumatic hoses from the part to be replaced (see chapter "Removing the pneumatic hoses")
4. Dismantle the defective part and replace it
5. Reconnect the pneumatic hoses (see chapter "Fitting the pneumatic hoses")
6. Reassemble the control unit in reverse order as described and install it

### Removing the pneumatic hoses

Before replacing a pneumatic part, all corresponding pneumatic hoses should always be disconnected first. This happens by pressing the ring on the quick release coupling of the hose. The hose can be pulled out easily.

### Fitting the pneumatic hoses

In order to reconnect the pneumatic hoses, proceed as follows:

- Insert the hose in the quick release coupling up to the end stop. The hose is held firmly again



---

**Note:**

**If there are any problems or uncertainties, please contact a ITW Gema service center!**

---

---

## Error diagnosis of the software

### General information

The correct function of the OptiStar CG07-P Gun control unit is constantly monitored. If the equipment software determines a fault, an error message is indicated with an error code. Following is monitored:

- High voltage technology
- Pneumatic system
- Power supply

## Error codes



The error diagnosis codes (error codes/help codes) are shown in the display **A5**. The error codes are stored in an error list in the order of their appearance. Each error in the list must be individually acknowledged with the keys **T10** or **T11**.

The error codes are shown with the format **Hnn**, whereby **nn** is the numeric code, if necessary with a leading zero.

The errors are displayed in the order of their appearance. The keys **T10** and **T11** cannot be used for other functions, as long as an error code is shown on **A5**.

Here is the complete listing of all error codes possible for the OptiStar CG07-P Gun control unit:

Code	Description	Criteria	Remedy
<b>Pneumatics:</b>			
<b>H06</b>	Trigger valve	Solenoid coil current lower than preset limiting value Valve defective, main board or cable defective	Main solenoid valve error, connection cable from main solenoid valve to basic electronics is missing, check main solenoid valve
<b>High voltage:</b>			
<b>H11</b>	Gun error	No oscillation Cable broken, oscillator or gun defective	Replace gun cable, cascade etc.
<b>Power supply:</b>			
<b>H20</b>	Overvoltage +15 V supply	Power pack defective or overloaded	Replace the power pack, if error is permanent
<b>H21</b>	Undervoltage +15 V supply	Power pack defective or overloaded	Replace the power pack, if error is permanent
<b>H22</b>	Undervoltage -15 V supply	Power pack defective or overloaded	Replace the power pack, if error is permanent
<b>H23</b>	Undervoltage +5 V supply	Power pack defective or overloaded	Replace the power pack, if error is permanent
<b>EEPROM (equipment memory):</b>			
<b>H24</b>	EEPROM content invalid	EEPROM error	Load factory settings, initialize EEPROM (see therefore chapter "RAM reset")
<b>H25</b>	Timeout during EEPROM writing	EEPROM error	Load factory settings, initialize EEPROM (see therefore chapter "RAM reset")
<b>H26</b>	Values not correctly stored in EEPROM during switching off	EEPROM error	Load factory settings, initialize EEPROM (see therefore chapter "RAM reset")
<b>Throttle motors:</b>			
<b>H60</b>	Conveying air reference position not found	Throttle motor or needle blocked, limit switch defective, throttle motor error	Calibrate again, replace throttle valve
<b>H61</b>	Supplementary air reference position not found	Throttle motor or needle blocked, limit switch defective, throttle motor error	(see above)
<b>H62</b>	Electrode rinsing air reference position not found	Throttle motor or needle blocked, limit switch defective, throttle motor error	(see above)

Code	Description	Criteria	Remedy
H63	Shaping air / fluidizing air reference position not found	Throttle motor or needle blocked, limit switch defective, throttle motor error	(see above)
H64	Conveying air throttle does not move	Short circuit in limiting switch, throttle motor defective	(see above)
H65	Supplementary air throttle does not move	Short circuit in limiting switch, throttle motor defective	(see above)
H66	Electrode rinsing air throttle does not move	Short circuit in limiting switch, throttle motor defective	(see above)
H67	Shaping air throttle does not move	Short circuit in limiting switch, throttle motor defective	(see above)
H68	Conveying air position lost	Lost steps, limit switch defective, throttle motor defective	(see above)
H69	Supplementary air position lost	Lost steps, limit switch defective, throttle motor defective	(see above)
H70	Electrode rinsing air position lost	Lost steps, limit switch defective, throttle motor defective	(see above)
H71	Shaping air position lost	Lost steps, limit switch defective, throttle motor defective	(see above)
<b>Dense phase pump:</b>			
H80	Dense phase pump recognition	Dense phase pump not connected	Connect the dense phase pump
H81	Dense phase pump feedback	Dense phase pump not connected	Fault elimination
H82	Total air volume (GL) minus transport air (TL) is lower than 0	Total air volume (GL) is lower than the resulting transport air (TL) from PA and C2	Redefine the total air volume (GL)

## Help codes list

The last appeared four errors are stored in a list by the software. If an error appears, which is already in the list, it will not be listed again. If the list is full, no more new entries are added.

## Appearance of errors

It is possible that an error appears just shortly, but after the acknowledgement it will disappear. In this case, switch off the OptiStar control unit and switch it on again (reset by restarting).



# Spare parts list

---

## Ordering spare parts

When ordering spare parts for powder coating equipment, please indicate the following specifications:

- Type and serial number of your powder coating equipment
- Order number, quantity and description of each spare part

**Example:**

- **Type** OptiStar CG07-P Gun control unit  
**Serial number** 1234 5678
- **Order no.** 203 386, 1 piece, Clamp - Ø 18/15 mm

When ordering cable or hose material, the required length must also be given. The spare part numbers of this yard/meter ware is always marked with an \*.

The wear parts are always marked with a #.

All dimensions of plastic hoses are specified with the external and internal diameter:

**Example:**

Ø 8/6 mm, 8 mm outside diameter (o/d) / 6 mm inside diameter (i/d)



---

**WARNING!**

**Only original ITW-Gema spare parts should be used, because the hazardous location approval will be preserved that way! The use of spare parts from other manufacturers will invalidate the ITW Gema guarantee conditions!**

---

## OptiStar CG07-P Gun control unit - general

	OptiStar CG07-P Gun control unit - complete	1005 458
1	Front plate - see corresponding spare parts list	
2	Enclosure and power pack - see corresponding spare parts list	
3	Rear wall - see corresponding spare parts lists	
4	Protective cover	1004 426
5	Shock protection	1001 058
	Program table	1005 903
	OptiStar CG07-P short instructions	1005 902



OptiStar CG07-P Gun control unit



## OptiStar CG07-P - inside rear wall

1	Throttle motor - complete	1000 064
4	Elbow joint - 1/8"a, Ø 6 mm	254 061
5	Fluidizing pad - 1/8"a	237 264
6	T-piece - 1/4"i-1/4"a-1/4"i	262 064
7	Solenoid valve - 1/4" (3/8"), NW11,5 - 24V	262 455
9	Elbow joint - 1/4", Ø 6 mm, 2x2	1001 933
11	Plastic tube - Ø 6/4 mm	103 144*
12	Plug - Ø 6 mm	251 925
13	Valve cable - CG07-P	1001 410
14	DPP01 interface	1004 144
15	Elbow joint - 1/4"a, Ø 6 mm	265 691

\* Please indicate length

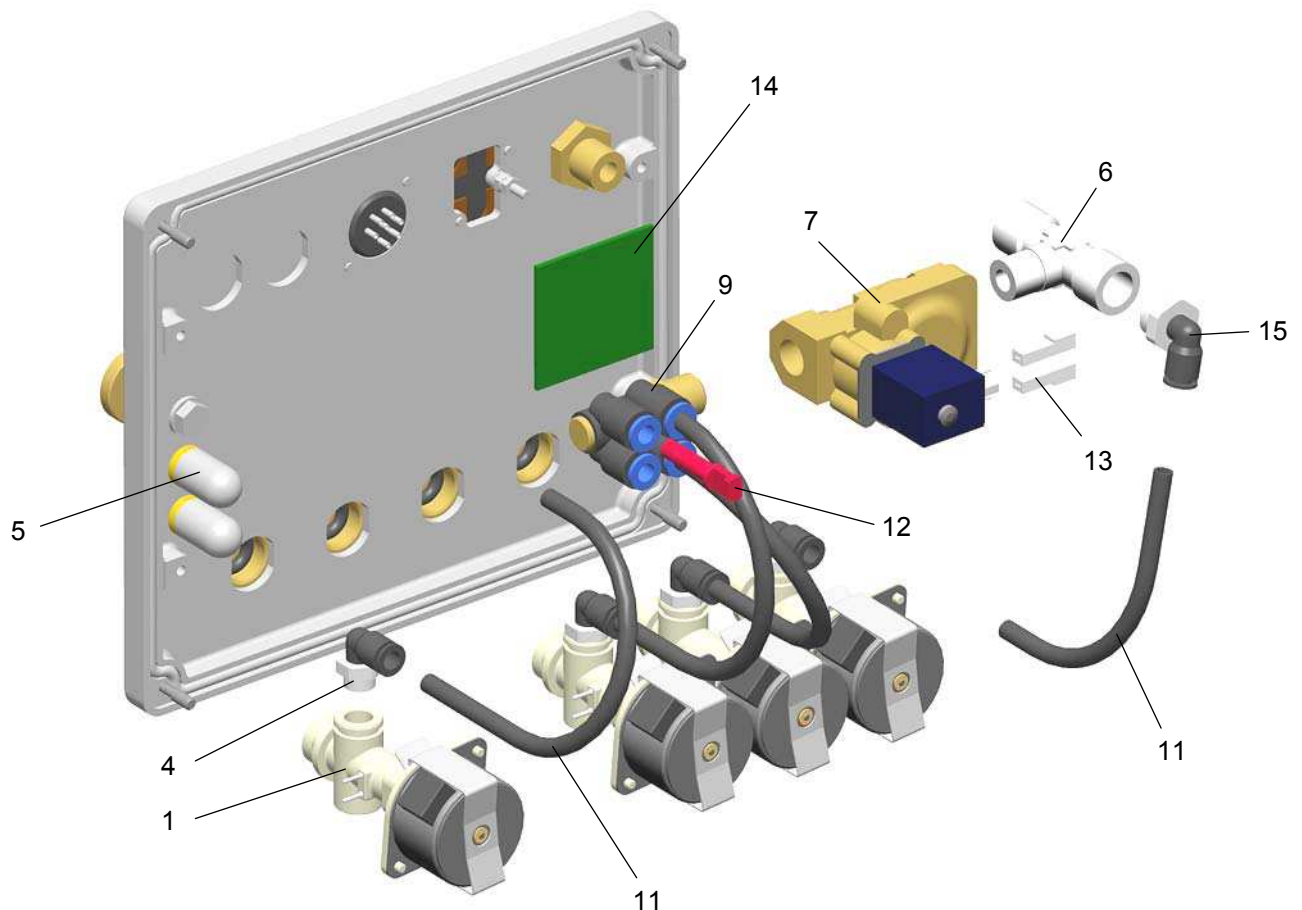

OptiStar CG07-P - inside rear wall

## OptiStar CG07-P - outside rear wall

1	Rectus quick release connection - complete	1001 517
2	Hose connection - complete, Ø 6/4 mm	1001 520
3	Milled nut - M6	200 433
4	Shake proof washer - A-type, M6	200 450
5	Hexagon nut - M6	200 417
6	Washer - Ø 6.4/12.5x1.6 mm	200 476
7	Mains connection CG07-P	1001 176
8	Cap screw - M3x8 mm	202 363
9	Gun connection CG07-P	1001 179
10	Elbow joint - 1/4"i, Ø 8 mm	254 002

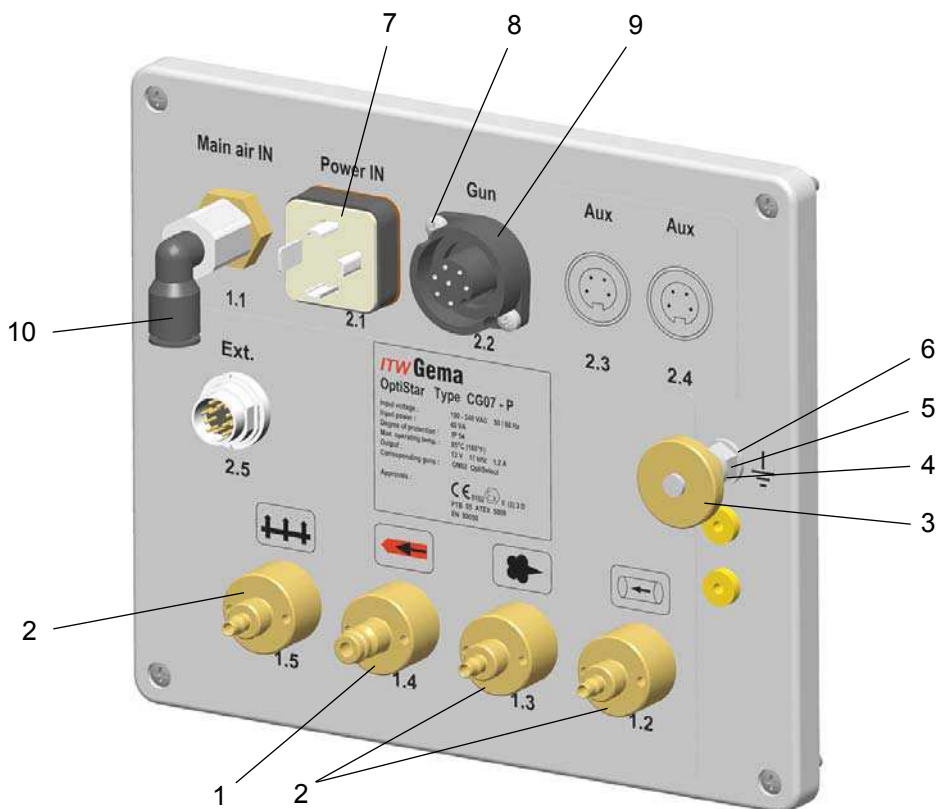

OptiStar CG07-P - outside rear wall

## OptiStar CG07-P - enclosure and power pack

1	Enclosure - CG07-P Gun control unit	1001 435
2	Power pack - 15 VDC	374 059
3	Power pack power supply	1000 388
4	Mainboard power supply	1001 178
5	Spacer - Ø 4, Ø 4.8/4.8 mm, PA	263 508
6	Fuse - 4 AF	262 897

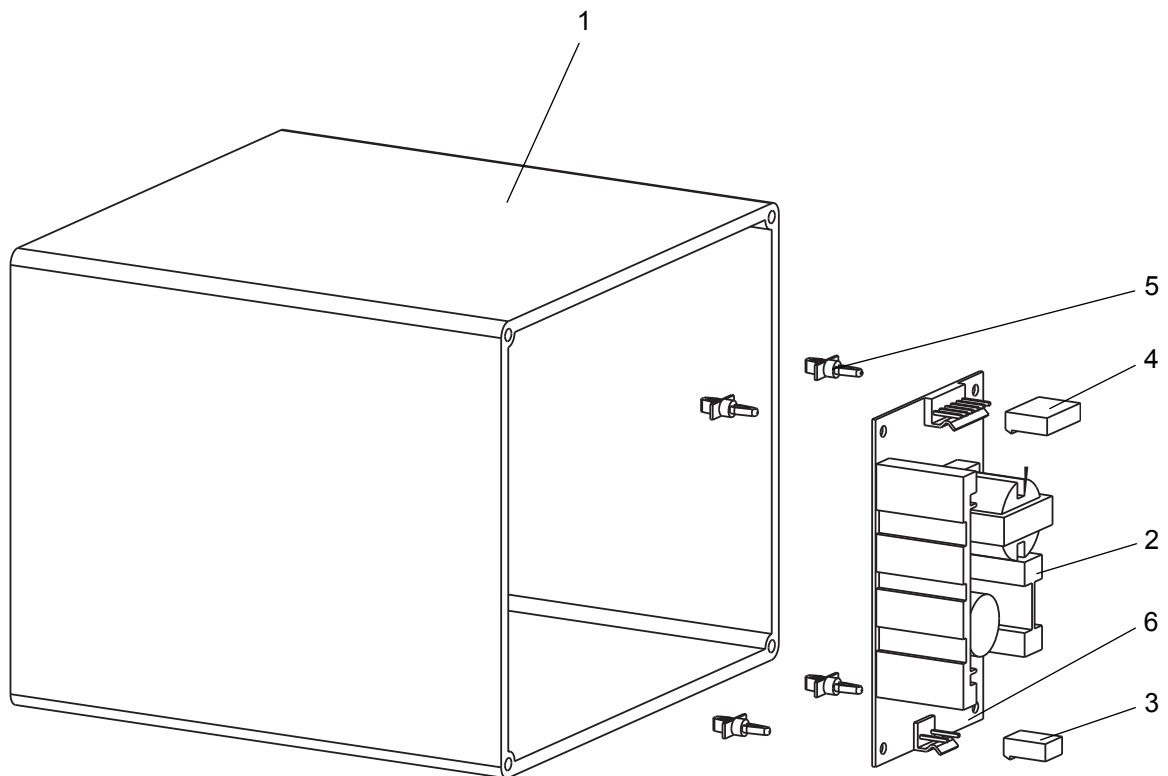

*OptiStar CG07-P - enclosure and power pack*

## OptiStar CG07-P - front plate

	Front plate - complete	1005 445
1	Front plate with foil keyboard	1000 394
3	OptiStar mainboard - complete, with display	1004 867
4	Locknut - M3	262 498
5	Washer - Ø 3.2/7x0.5 mm	201 944
6	Spacer sleeve - Ø 3.2/6x6 mm	1001 925
7	Spacer sleeve - Ø 3.2/6x15 mm	1001 926
8	Compression spring - 0.5x6.3x13.5 mm	230 251
9	Special screw	1000 400
	EPROM (not shown)	1004 868

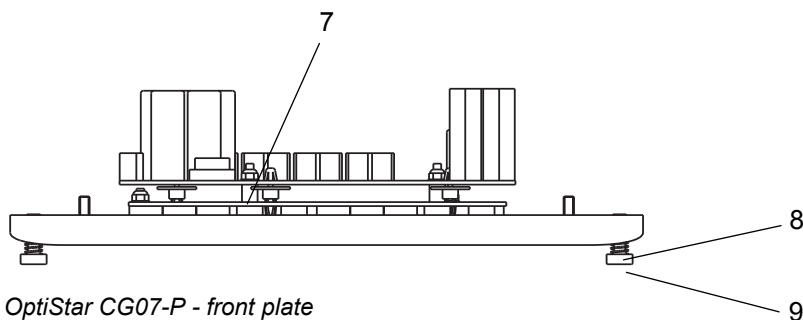
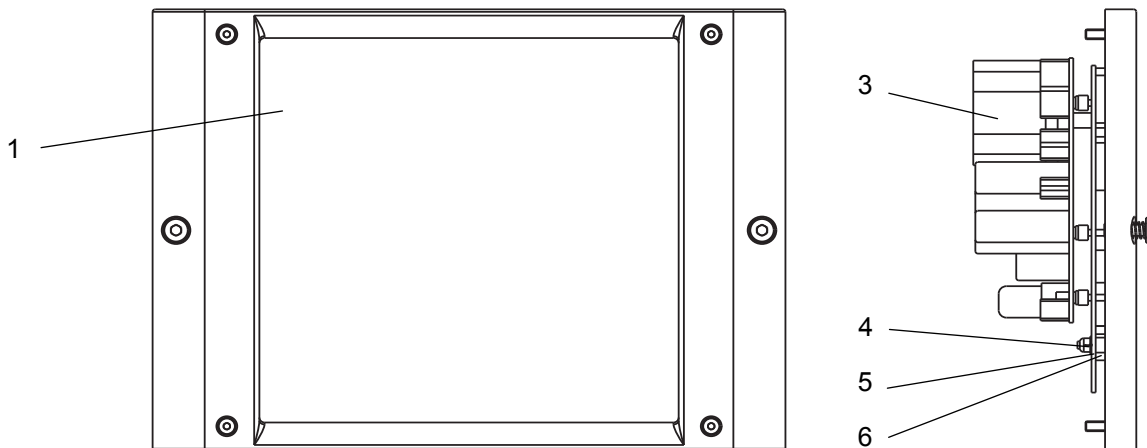

## Diffuser

Diffuser - complete		1005 263
1	Adaptor piece	1005 260
2	Fluidizing tube	1005 262
3	O-ring - Ø 19x1.5 mm	1005 749
4	Connector	1005 261
5	O-ring - Ø 12x1.5 mm	1000 822
6	Elbow joint - 1/8"a, Ø 6 mm	254 061

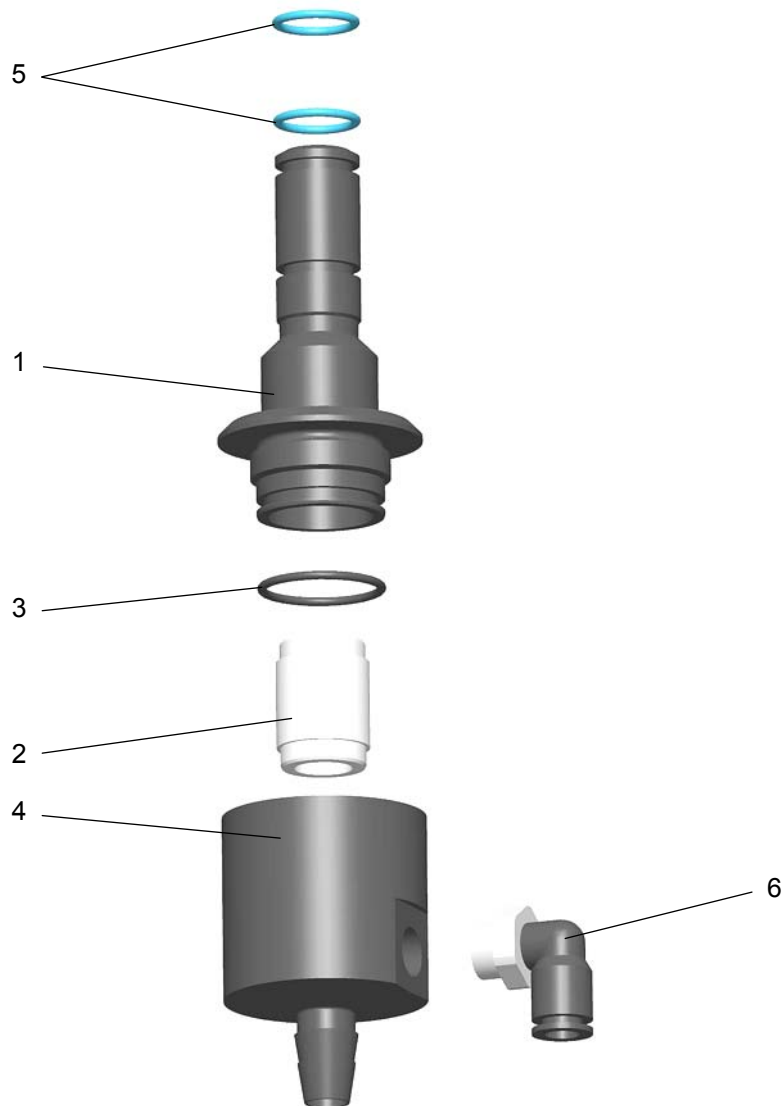

OptiSpray F Manual coating equipment - diffuser