

Vertical Module (ZA17)

Precise positioning of multiple gun axes

The ZA17 vertical module is utilized in combination with the ZS05 stationary axis for precise movement and positioning of multiple UA05 and UA05-x gun axes on the coating object. Multiple ZA17 vertical modules can be configured to suit the application; side by side and/or above each other on a single ZS05 axis. The ZA17 modules can be used to place the gun in a fixed position or an oscillating range to match the application requirements.

The axes are controlled using the MagicControl MAX system control. For part recognition with scanners, a separate recognition zone is created for each ZA17 module.

The ZA17 vertical module is particularly suitable for the accurate and targeted gun positioning during the application of complex geometries and inclined beams.

Main features:

- Precise vertical positioning of the gun to the coating object
- Up to six ZA17 modules can be mounted on the ZS05 axis in total (three per side)
- Two UA05 gun axes or one UA05-x axis can be used per ZA17 module
- Up to eight UA05 axes can be operated on the ZS05 axis in total
- Left and right hand side arrangement with a gun distance of 350 mm

Customer benefits:

- Increased automation for complex application requirements and difficult part geometries
- Reduction of the booth footprint through the combination of multiple axes into one unit
- Powder savings through increased automation with individual gun positioning
- Automatic coating and increased coverage of angled contours through precise positioning and continuous adjustment of fixed guns
- 110 – 300 mm vertical gun spacing reduces the distance between coating zones, maximizing the effectiveness of single-axis coverage in recessed areas
- End-to-end data networking for performance monitoring and tracking



ZA17 modules on the ZS05 axis



Two UA05 or one UA05-x axis can be mounted on a ZA17 module



Maximum assembly - up to three ZA17 modules above each other on both sides of the ZS05 with 350 mm gun distance (C)

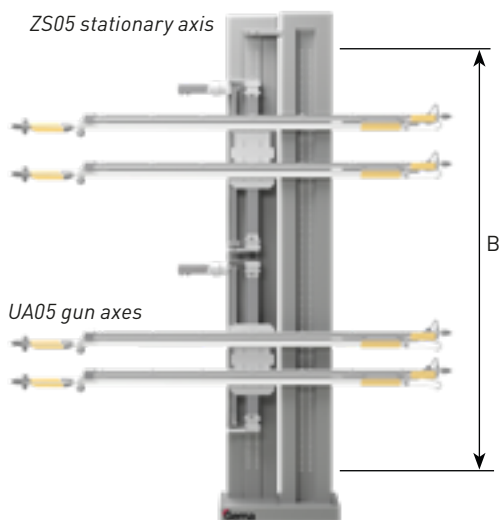
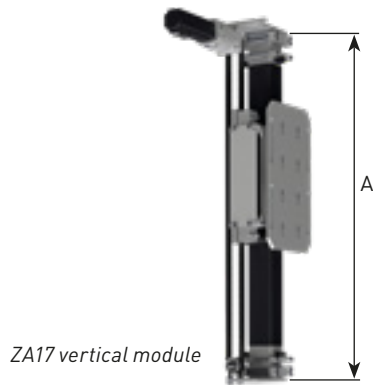

Technical data ZA17

Vertical module	ZA17
Stroke speed	0.08 – 0.4 m/s
Acceleration	0.1 – 1.5 m/s ²
Number of gun axes	max. 2 gun axes UA05 (110 – 300 mm distance) per ZA17 module or 1 gun axis UA05-x per ZA17 module
Positioning system	Pulse generator integrated in synchronous motor
Voltage	230 V; 50 / 60 Hz
Temperature range	0 °C – +40 °C / 32 °F – +104 °F
ATEX zone	CE II 3 D (ATEX Zone 22)
Synchronous motor	400 watt, IP 54 insulation class F
Type: ZA17-x	5 7.5 10 12.5 15
Stroke of ZA17 module [mm]	500 750 1000 1250 1500
Height (A) [mm]	1095 1345 1595 1845 2095

Technical data ZS05

Stationary axis	ZS05
Type: ZS05-x	20 25 30 35
Assembly height (B) [mm]	2000 2500 3000 3500
Loading capacity	max. 6 ZA17 modules (3 on each side) with max. 8 UA05 axes per ZS05

Possible configurations:

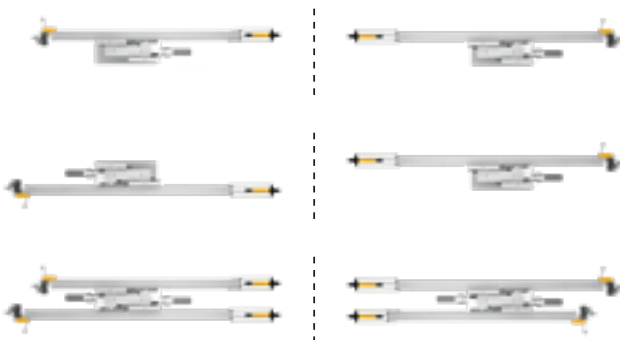

Associated system components:

- MagicControl MAX system control
- Gun axes UA05
- Gun axis UA05-x
- OptiGun® GA04-X automatic gun including nozzle assortment
- Part detection system
- Adaption plates for direct mounting of UA05, UA05-x or GA04-X on ZS05

Gema Switzerland reserves the right to make technical changes without prior notice!