

# Reciprocator (ZA07/ZA08/ZA15)

## Smooth running characteristics for perfect coating results

Short or long stroke - the ZA Reciprocator offers simple programming, smooth running and high loading capacity. The heavy load version of the reciprocator has a loading capacity up to 100 kg.

### Customer Benefits:

- Long-stroke and short-stroke operation
- High loading capacity and stability
- Slim column design allows space-saving arrangement of the guns
- Extremely smooth running through toothed belt transmission
- Maintenance-free AC motor
- Free axis programming
- Storable programs
- Bus/CAN-Bus technology integrated into the control unit

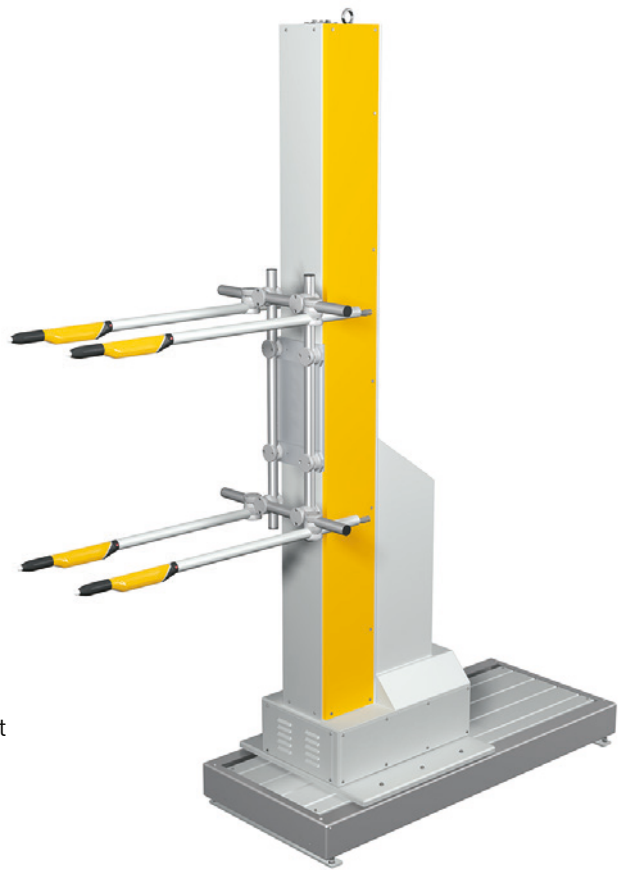

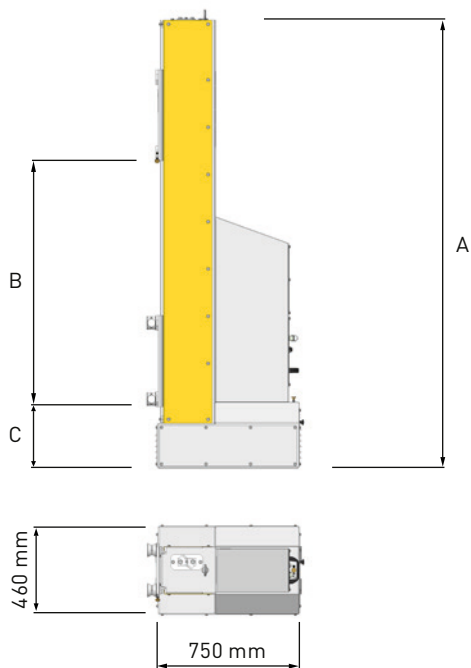

## Technical data

	ZA07/08	ZA15
Stroke speed	0,01 - 0,6 m/s	0,08 - 0,4 m/s
Acceleration	0,1 - 2,0 m/s <sup>2</sup>	0,1 - 1,5 m/s <sup>2</sup>
Loading capacity	max. 50 kg	max. 100 kg

Positioning system	Incremental encoder
Voltage	230 V, 50/60 Hz
Temperature range	10 °C - +40 °C
Zone definition	⊕ II 3 D (ATEX Zone 22)
Motor type	three-phase asynchronous motor
Power	0,75 kW

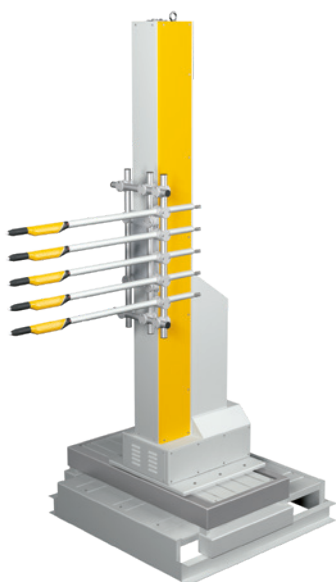

Combination example with 3 axes

Reciprocator	13	18	23	28	33	38
ZA07/08	✓	✓	✓	✓	✓	✓
ZA15	✓	✓	✓	✓	-	-
Total height (A)	2.385 mm	2.885 mm	3.385 mm	3.885 mm	4.385 mm	4.885 mm
Adjustable stroke (B)	1.300 mm	1.800 mm	2.300 mm	2.800 mm	3.300 mm	3.800 mm
Lower inflection point (C)	326 mm	326 mm	326 mm	326 mm	326 mm	326 mm

### Associated system components

- MagicControl for ZA07 and ZA15
- OptiMove control unit for ZA08
- Automatic gun OptiGun GA03-X

Gema Switzerland reserves the right to make technical changes without prior notice!

#### Gema Switzerland GmbH

Mövenstrasse 17 | 9015 St.Gallen | Switzerland  
 T +41 71 313 83 00 | F +41 71 313 83 83  
 www.gemapowdercoating.com

