

# Application Success Stories

## Electrical – INDIA Lighting Fixtures



High Quality Finish

Faster Color Change

Repeatable Results

# Application Success Stories

## Installation Key Data - Line 1

**Parts:** Electrical Fixtures  
**Part Size:** 0.8M (H) x 0.3M (W)  
**Conveyor Speed:** 1.8m/min

### **Scope of Delivery :**

- 1 x MagicCompact® EquiFlow® BA04
- 2 x ZA07-13 / XT10 reciprocators
- 1 x OptiCenter OC02 with OptiSpray AP01 Application Pumps
- 1 x MagicControl 4.0 (CM40) with light barrier
- 1x OptiFlex® Automatic AS06 –for 14 guns
- 12 x OptiGun® GA03
- 2 x OptiSelect® GM03
- 1 x 12000 Nm3/hr after filter & cyclone
- Fire Fighting System



# Application Success Stories

## Layout - Line 1

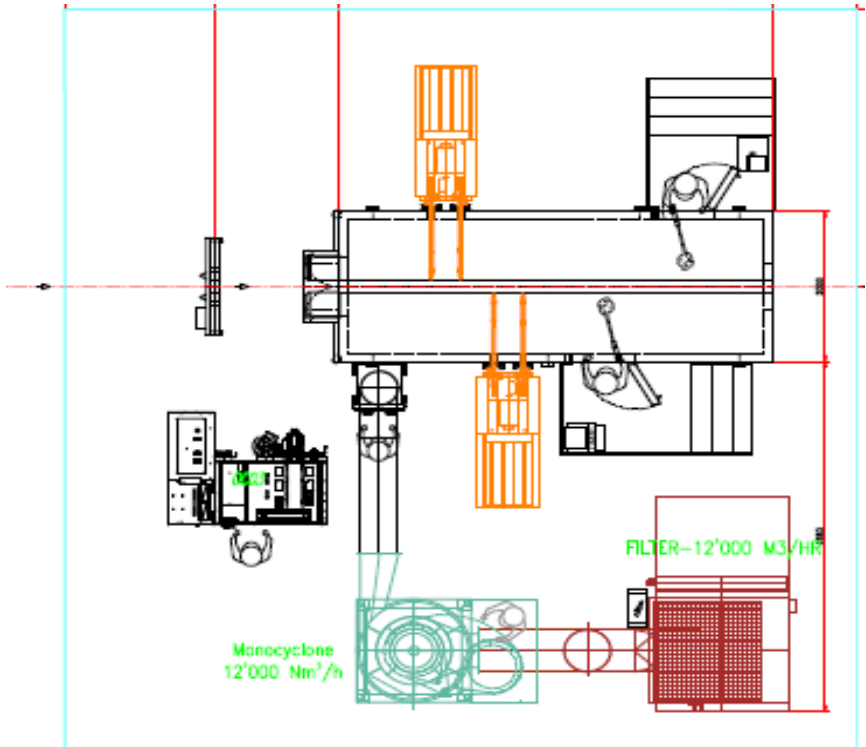

# Application Success Stories



# Application Success Stories

## Installation Key Data - Line 2

**Parts:** Electrical Fixtures  
**Part Size:** 0.4M (H) x 0.3M (W)  
**Conveyor Speed:** 0.6m/min (Floor Conveyor)

### **Scope of Delivery :**

- 2 x MagicPlus Stainless Steel Booth
- 2 x OptiFlex® Automatic AS07 for 2 guns
- 2 x OptiGun® GA03 for each booth
- 1 x 12000 Nm3/hr after filter
- 2 x Monocyclone
- 2 x PS2 Sieve



# Application Success Stories

## Layout - Line 2

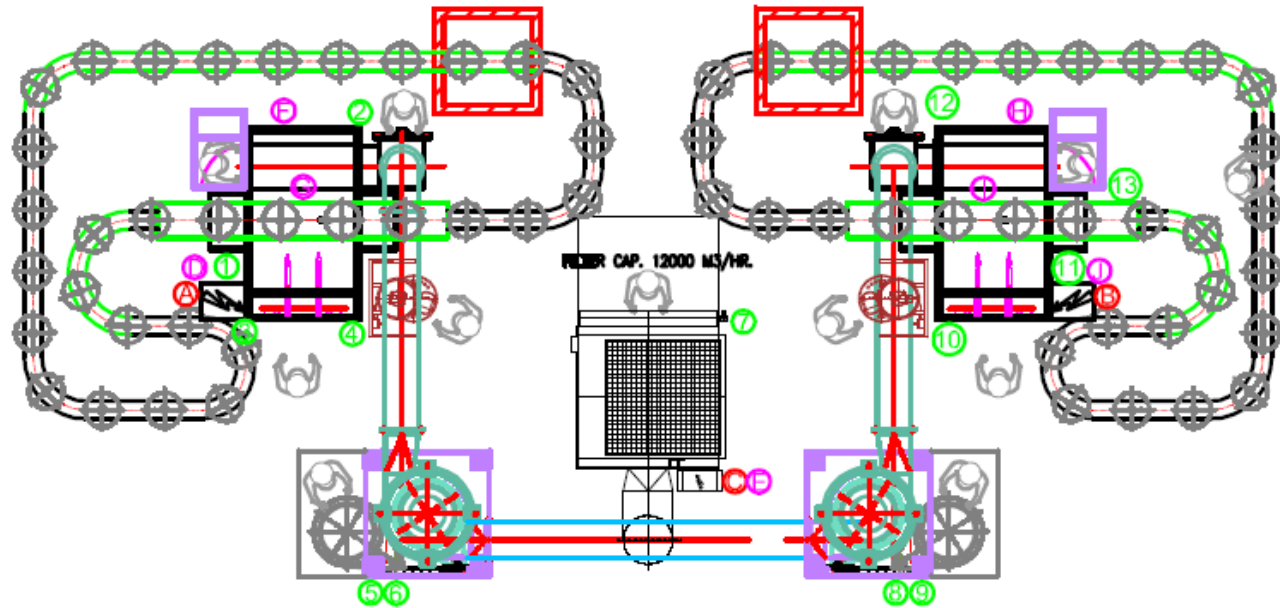



# Application Success Stories



# Application Success Stories



- Maximum coating coverage of complicated parts
- Higher transfer efficiency
- Reduced powder waste
- Increased flexibility
- Faster color change
- Repeatable results
- Top quality finish
- Higher recovery efficiency